

NEW MAR



OWNER'S GUIDE

1997 London Aire

F I F T H W H E E L

NEWMAR CORPORATION OWNER'S GUIDE

Table of Contents

Chapter 1	General Information
Chapter 2	Towing & Safety Precautions
Chapter 3	Air Conditioning & Heating
Chapter 4	Appliances & Accessories
Chapter 5	Cabinets & Furniture
Chapter 6	Structure Features
Chapter 7	Electrical Features
Chapter 8	Slide Out Features
Chapter 9	Exterior Features
Chapter 10	Interior Features
Chapter 11	Plumbing & Bath Features
Chapter 12	Construction Features
Chapter 13	Windows, Awnings, Vents, & Doors
Chapter 14	Routine Maintenance
Chapter 15	Charts & Diagrams

Welcome to the exciting world of RV traveling and the growing family of recreational vehicle owners.

Congratulations on your purchase of a Newmar product. We sincerely thank you for choosing Newmar as your recreational vehicle. We trust this guide will help you to better understand and enjoy your new RV. We hope that you will enjoy many miles of traveling. Your new vehicle was built with care using today's technology and old world craftsmanship. We, at Newmar, strive to build vehicles that are safe, dependable, and comfortable to provide years of carefree, pleasant traveling.

This Owner's Guide, along with the Video Guide, should be kept in your vehicle for quick reference. Take time to get acquainted with your unit and how it operates. Carefully read both the instructions in this guide and the booklets supplied by the component manufacturers for important operation, safety, and maintenance information. Your dealer should be consulted should you have any questions. If your dealer is unable to answer the questions to your satisfaction he will refer you to our staff for help. Our customers are extremely important to us and we will make every effort necessary to ensure your satisfaction.

Again, thank you and welcome to our Newmar family.

Newmar Corporation

CHAPTER 1

GENERAL INFORMATION

Table of Contents

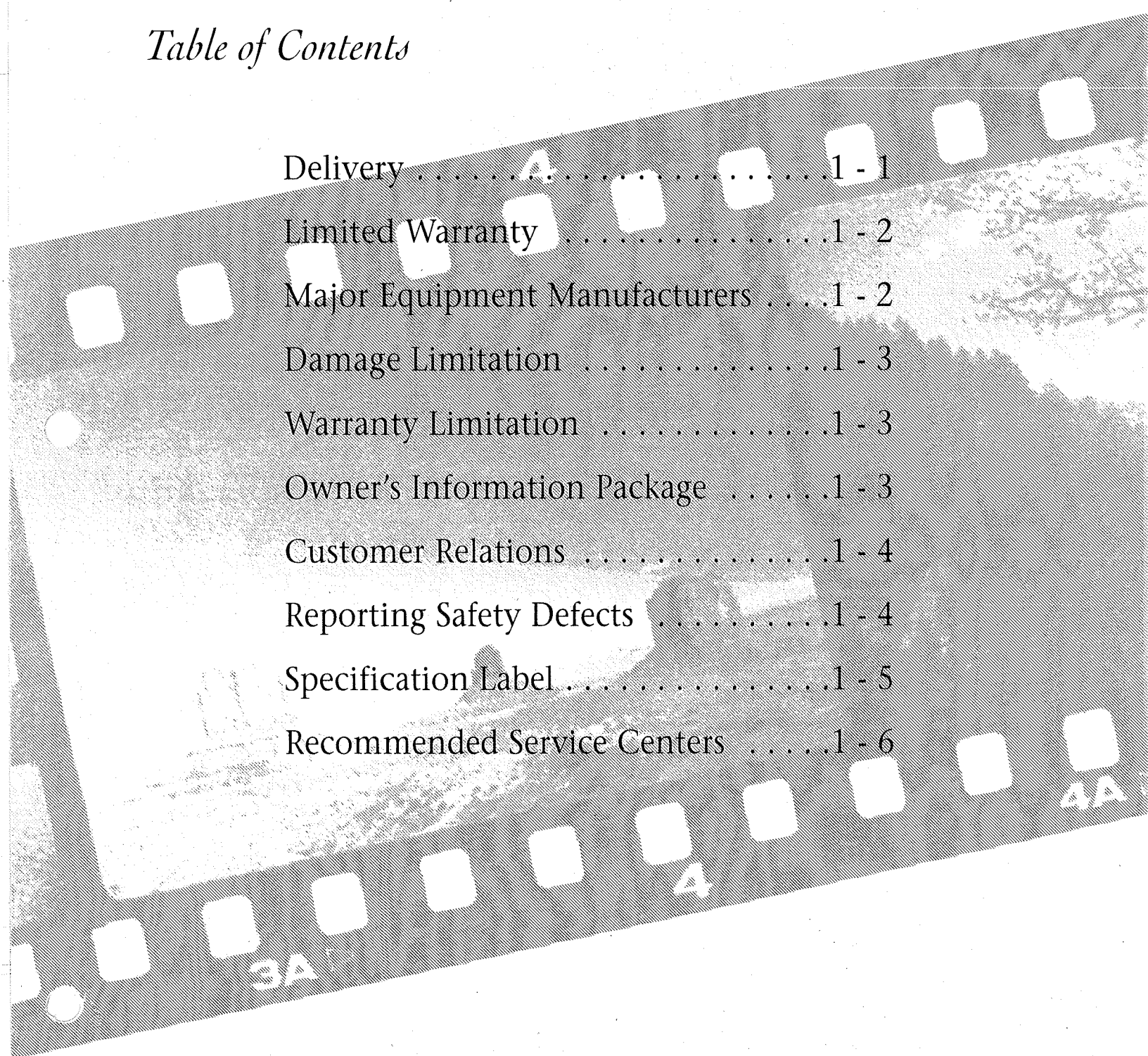

Delivery	1 - 1
Limited Warranty	1 - 2
Major Equipment Manufacturers	1 - 2
Damage Limitation	1 - 3
Warranty Limitation	1 - 3
Owner's Information Package	1 - 3
Customer Relations	1 - 4
Reporting Safety Defects	1 - 4
Specification Label	1 - 5
Recommended Service Centers	1 - 6

DELIVERY

Throughout the manufacturing process, your vehicle has been inspected by our qualified technicians. However, our final inspection at the factory is not to be the last one. The pre-delivery inspection and systems check your dealer performs are the final inspections done to the unit prior to you receiving your new coach. Your dealer is also available to assist you in understanding the limited warranties and completing any necessary forms to activate the warranties for the various appliances and accessories installed in your unit.

Dealer Responsibilities

1. A pre-delivery inspection and systems check. Thoroughly inspecting the vehicle and the operation of the factory installed components.
2. A customer walk through. This is done to familiarize the customer with the vehicle, its systems and components, and their operation.
3. Delivery of the Owner's Information Package. This package contains the warranty cards and registrations for the vehicle and factory installed components that carry a separate warranty. The detailed operating and maintenance instructions on these components are also included in this package.
4. Assisting the customer in completing the component registration forms, at the customer's request. To avoid loss of warranty coverage, the dealer should review the limited warranty provisions with the customer stressing the importance of filing warranty cards and registrations to the component's manufacturers within the prescribed time limit.
5. Providing the customer with information regarding warranty and non-warranty work on the vehicle and its separately warranted components whether the customer is in or out of the area.

Customer Responsibilities

The customer is responsible for regular and proper maintenance of the vehicle. Properly maintaining your vehicle will prevent conditions arising from neglect that are not covered by your Newmar limited warranty. The maintenance guidelines in this manual and any other applicable manual should be followed. It is your responsibility and obligation to return the vehicle to an authorized dealer for repairs and service.

To assist you in avoiding problems with your vehicle, we recommend you do the following:

- a. Read the warranty. Go over it thoroughly with your dealer.
- b. Inspect the vehicle. Do not accept delivery until you have gone through the unit with the dealer. Newmar has provided a check list to be used during retail delivery. Check each item on the list and make sure he does the same. Do not sign this checklist until you have done this.
- c. Ask questions about anything that you do not understand concerning your recreational vehicle.
- d. When taking delivery, set an appointment for adjustments. This appointment should be approximately two (2) weeks after you accept delivery.

DAMAGE LIMITATION

Newmar Corporation will not be responsible for any incidental or consequential damages, including (but not limited to) loss of vehicle use, loss of time, inconvenience, expenses for travel, lodging, transportation charges, loss or damage to personal property or loss of income.

Please note, however, that some states do not allow the exclusion or the limitation of incidental or consequential damages, so the above limitation may not apply to you.

Oral and Implied Warranty Limitation

Implied warranties such as any warranty of merchantability or fitness for a particular purpose covers only the original purchaser. Coverage terminates 365 days from the date of purchase or on the date the original purchaser sells or transfers his interest in the recreational vehicle to a subsequent owner.

It is the intent of Newmar Corporation to comply with the Magnuson-Moss Warranty Act and the Federal Trade Commission's prescribed rulings. Newmar Corporation is not liable for, and will not recognize, any warranty other than the implied warranties under state law and the written warranty contained in this document. In other words, no other warranty, written or oral, is given by Newmar Corporation.

Please note, however, some states do not allow limitations on how long an implied warranty lasts, so the above limitation may not apply to you.

Transfer Limitation

This warranty is not assignable or transferable.

Legal Rights

This warranty gives you specific legal rights and you may also have other rights that may vary from state to state.

Reserved Right to Change

Newmar Corporation reserves the right to make changes or improvements in vehicles it produces in the future, without imposing on itself any duty to install the same improvements in vehicles it has previously manufactured.

Owner's Information Package

Included in this package are valuable documents about your vehicle and its components and systems. The Newmar Owner's Guide does not cover every possible detail of equipment, standard and/or option, installed on or in your vehicle. Consulting the booklets and instruction manuals in this package will help you safely operate, maintain, and troubleshoot these items.

SPECIFICATION LABEL

There are two main numbers used to identify the vehicle. The Vehicle Identification Number (VIN) is the legal identification of the completed vehicle. The VIN is the number used by the state for vehicle registration. The Newmar Serial Number (1) is a five digit number that is needed whenever making an appointment for service or ordering parts through your Newmar Dealer or Service Center. This number can be found on the placard in the kitchen overhead and on the Customer Care card received from Newmar. Below is a sample of the placard located in the kitchen.

1. The Newmar Serial Number.
2. Last five digits Vehicle Identification Number (VIN)
3. Model Number of the Unit
4. Model Year of the Unit
5. Manufacturer, Model Number, and Serial Number of factory installed appliances

SPECIFICATION LABEL

SERIAL # _____ CHASSIS # _____ MODEL # _____
 DECOR # _____ WOODCOLOR _____ MODEL YEAR _____
 HEIGHT _____ DRY WEIGHT _____ LENGTH _____

APPLIANCE INFORMATION				
	MODEL #	SERIAL #	MODEL #	SERIAL #
FRONT AC			REAR AC	
FRONT T.V.			REAR T.V.	
FRONT FURN.			REAR FURN.	
WATER HEATER			RANGE	
GENERATOR			AUX. HEATER	
FRONT RADIO			REAR RADIO	
WASHER			DRYER	
CD RADIO			VCR	
CONVERTER			MICROWAVE	
REFRIGERATOR			BLENDER	
SAFE			FREEZER	

Notes

R & S SALES & SERVICE, INC.

218 S. Lake of the Woods Road
Mahomet, IL 61853
(217)586-2055 Fax (217)586-2382

WHISPERING PINES CAMPGROUND INC.

6245 N. Seneca Road
Morris, IL 60450
(815)942-0922 Fax (815)942-0372

INDIANA**DON'S CAMPER SALES INC.**

Box 373, U.S. 41 S.
Boswell, IN 47921
(317)869-5009 Fax (317)869-5009

HART CITY RV SERVICE INC.

2301 S. Nappanee Street
Elkhart, IN 46517
(219)295-5793 Fax (219)294-2026

INDY RV CENTER INC.

State Rd. 37, S. Smith Valley Rd., P.O. Box 447
Greenwood, IN 46142
(317)881-0300 Fax (317)881-0431

LEE'S RV CENTER INC.

7247 State Road 46 E.
Batesville, IN 47006
(812)934-3210 Fax (812)934-3345

THE RV CENTER INC.

3360 E. Lincolnway
Columbia City, IN 46725
(219)244-3898 Fax (219)244-3414

TOM STINNETT HOLIDAY RV CTR. INC.

560 Kopp Lane
Clarksville, IN 47129
(812)282-7718 Fax (812)288-9424

WETNIGHT RV SALES & SERVICE INC.

4401 U.S. 41 N., P.O. Box 5197
Terre Haute, IN 47805
(812)466-3961 Fax (812)466-6851

IOWA**HEROLD TRAILER SALES**

1806 W. 2nd Avenue, Highway 92 W.
Indianola, IA 50125
(515)961-7405 Fax (515)961-3674

RV CENTRAL

3001 S. 2nd Avenue
Sheldon, IA 51201
(712)324-5395 Fax (712)324-5396

WALKER TRAILER SALES, INC.

Highway 18 W., Box 633
Nora Springs, IA 50458
(515)749-2321 Fax (515)749-2321

KANSAS**HARPER CAMPERLAND INC.**

1200 E. 10th, P.O. Box 1993
Great Bend, KS 67530
(316)792-5170 Fax (316)792-8466

HARPER CAMPERLAND INC.

117 W. 14th
Harper, KS 67058
(316)896-2862 Fax (316)896-2858

JAYHAWK CAMPER SALES

24105 W. 43rd
Shawnee, KS 66226
(913)422-5677 Fax (913)422-7147

WILCOX HOMES & RV CENTER

835 N.E. Highway 24
Topeka, KS 66608
(913)357-5111 Fax (913)232-1574

KENTUCKY**YOUNGBLOOD RV CENTER INC.**

Rt #8, Highway 45 N.
Mayfield, KY 42066
(502)247-8591 Fax (502)247-0604

LOUISIANA**JACKIE EDGAR RV CENTER INC.**

3008 Cameron Street
Lafayette, LA 70506
(318)232-1941 Fax (318)233-1147

MILLER RV

12912 Florida Boulevard
Baton Rouge, LA 70815
(504)275-2940 Fax (504)275-6807

PREMIERE RV OUTLET INC.

1700 S. Siebarth Drive
Lake Charles, LA 70601
(318)436-8785 Fax (318)436-8706

MAINE**MOUNTAIN ROAD RV**

R.F.D. #1, Box 2620
Sabattus, ME 04280
(207)375-4091 Fax (207)375-4014

MARYLAND**BECKLEYS CAMPING CENTER**

11109 Angleberger Road
Thurmont, MD 21788
(301)898-3300 Fax (301)898-7093

MICHIGAN**CAMPER CENTER OF CLARE**

5139 E. U.S. 10
Clare, MI 48617
(517)386-9338

GAYLORD RV SALES & SERVICE

271 W. Johnson Road
Gaylord, MI 49735
(517)732-6141 Fax (517)731-2735

GENERAL TRAILER SALES-WATERFORD

5300 Highland Road
Waterford, MI 48327
(810)674-0346 Fax (810)674-3809

GENERAL TRAILER SALES-WIXOM

48500 12 Mile Road
Wixom, MI 48393
(810)349-0900 Fax (810)348-4150

HILLTOP RV & MARINE

2905 N. Lincoln Road
Escanaba, MI 49829
(906)786-7986 Fax (906)786-3421

MIDWAY MOTORHOMES INC.

5590 S. Division Avenue
Grand Rapids, MI 49548
(616)534-9641 Fax (616)534-6869

MODERN TRAILER SALES, INC.

449 S. Division Avenue
Wyoming, MI 49548-2110
(616)241-2925 Fax (616)241-5451

MINNESOTA**HILLTOP TRAILER SALES**

4560 Center Avenue N.E.
Minneapolis, MN 55418
(612)571-9103 Fax (612)571-2536

LANDEY'S RV INC.

6220 Highway 101 S.
Shakopee, MN 55379
(612)445-7081 Fax (612)445-4701

SHOREWOOD RV CENTER

7405 Highway 10 N.W.
Anoka, MN 55303
(612)421-2505 Fax (612)421-6076

MISSISSIPPI**RV REPAIR & SALES, INC.**

4749 Highway 80 W.
Jackson, MS 39209
(601)922-9425 Fax (601)922-5153

MISSOURI**CAPETOWN RV SALES**

I-55 & Airport Road, P.O. Box 1985
Cape Girardeau, MO 63702
(314)334-7152 Fax (314)334-9059

COACHLIGHT RV SALES INC.

Route 4, Box 515
Carthage, MO 64836
(417)358-7444 Fax (417)358-0856

THOMAS BILL CAMPER SALES INC.

5217 N. Lindbergh
St Louis, MO 63044
(314)731-2217 Fax (314)731-0269

MONTANA**BRETZ RV & MARINE**

2045 Mullan Road
Missoula, MT 59802
(406)721-4010 Fax (406)549-8078

NEBRASKA**DENNING RV**

3110 N. Broad
Fremont, NE 68025
(402)721-5030 Fax (402)721-5570

RICH & SON'S CAMPER SALES

5112 S. Antelope Drive
Grand Island, NE 68803
(308)384-2040 Fax (308)384-2043



CHILHOWEE RV CENTER
4037 Airport Highway, P.O. Box 236
Louisville, TN 37777
(423)970-4085 Fax (423)984-6213

TEXAS

CUSTOM RV
10400 I-40 E., P.O. Box 9352
Amarillo, TX 79112
(806)335-2336 Fax (806)335-2338

EAST TEXAS RV SALES
Drawer J, Highway 965
Kirbyville, TX 75956
(409)423-4032 Fax (409)423-5824

RON HOOVER CO. OF BOERNE INC.
29277 Interstate Highway 10 W.
Boerne, TX 78006
(210)755-2252 Fax (210)755-8644

RON HOOVER CO. OF CORPUS CHRISTI INC.
5029 Columbia Street
Corpus Christi, TX 78416
(512)854-5383 Fax (512)851-9578

RON HOOVER CO. OF DONNA INC.
502 Frontage Road
Donna, TX 78537
(210)464-7826 Fax (210)464-7829

RON HOOVER CO. OF HOUSTON INC.
5715 N. Freeway
Houston, TX 77076-4504
(713)695-2244 Fax (713)695-2288

RON HOOVER CO. OF ROCKPORT INC.
1510 W. Market Street, P.O. Box 747
Rockport, TX 78382
(512)729-9695 Fax (512)729-9698

BILLY SIMS TRAILER TOWN
1615 Loop 289 S.
Lubbock, TX 79423
(806)745-8791 Fax (806)745-8795

BILLY SIMS TRAILER TOWN
520 E. 2nd Street
Odessa, TX 79761
(915)580-3000

VOGT MOTOR HOMES
5624 Airport Freeway
Fort Worth, TX 76117
(817)831-4222 Fax (817)831-8234

UTAH

BLAINE JENSEN & SONS RV CENTERS
220 N. 650 W.
Kaysville, UT 84037
(801)544-4298 Fax (801)546-2717

VERMONT

PETE'S RV CENTER
4016 Williston Road
S. Burlington, VT 05403
(802)864-9350 Fax (902)862-4806

VIRGINIA

KOOGLER SALES & SERVICE, INC.
Route 2, Box 193
Fishersville, VA 22939
(703)942-5556 Fax (703)943-0853

RAINBOW ACRES CAMPING RESORT INC.
Route 2, Box 16
King & Queen Courthouse, VA 23085
(804)785-9441 Fax (804)785-2608

WASHINGTON

COURTSEY FORD INC.
19873 Viking Avenue N.W.
Poulsbo, WA 98370-0866
(206)697-2700 Fax (206)697-4085

RUSS DEAN'S AUTOMOTIVE FAMILY
1225 N. 32nd Place
Pasco, WA 99301
(509)545-9500 Fax (509)547-0016

TVETEN RV COMPANY
7700 Pacific Highway E.
Milton, WA 98354
(206)922-7770 Fax (206)922-8742

WEST VIRGINIA

BRAND TRAILER SALES
2045 Fairmont Avenue
Fairmont, WV 26554
(304)366-7104 Fax (304)363-9345

BURDETTE CAMPING CENTER
3749 Winfield Road
Winfield, WV 25213
(304)586-3084 Fax (304)586-3087

SETZER'S WORLD OF CAMPING
5840 Davis Creek Road
Barboursville, WV 25504
(304)736-5287 Fax (304)736-5992

ALBERTA

MAJESTIC RV SERVICE
2612 26th Street N.E.
Calgary, AB T1Y 1A5
(403)291-1203 Fax (403)291-9561

MAJESTIC RV SERVICE Lot #2
3516 Couatts Highway S.
LETHBRIDGE, AB T1J 4K6
(403)329-6344

VELLNER LEISURE PRODUCTS LTD.
7434-50 Avenue
Red Deer, AB T4P 1X7
(403)343-1464 Fax (403)340-8135

BRITISH COLUMBIA

HI-WAY RV LAND
6736 Glover Road
Langley, BC V2Y 1S6
(604)533-3421 Fax (604)533-0975

MIDTOWN RV LTD.
64 Industrial Avenue W.
Penticton, BC V2A 6M2
(604)492-5705 Fax (604)492-0430

TRAVELAND LEISURE VEHICLES LTD.
20529 Langley Bypass
Langley, BC V3A 5E8
(604)530-8141 Fax (604)530-9576

TRIANGLE HOMES LTD.
10299 McDonald Park Rd., P.O. Box 2518
Sidney, BC V8L 4B9
(604)656-1122 Fax (604)656-2161

WESTGATE RV CENTRE LTD.
1460 Byland Road
Kelowna, BC V1Z 1A7
(604)769-4525 Fax (604)769-5766

MANITOBA

WALT'S TRAILER SALES LTD.
5195 Portage Avenue, P.O. Box 70
Headingly, MB R0H 0J0
(204)837-8388 Fax (204)831-8674

NEW BRUNSWICK

CAMPERS ALLEY LTD.
P.O. Box 929, Rue Bourque
Bouctouche, NB E0A 1G0
(506)743-8404 Fax (506)743-8495

NEWFOUNDLAND

GANDER RECREATION PRODUCTS LTD
62 McCurdy Drive
Gander, NF A1V 1A2
(709)256-2501 Fax (709)651-3139

NOVA SCOTIA

BLUENOSE HOMES CO. LTD.
RR #4, Box 549
Bridgewater, NS B4V 2X6
(902)543-2519 Fax (902)543-2209

ONTARIO

FRONTIER RV
984 Finley Avenue
Orono, ON L1S 3V2
(905)983-8000 Fax (905)983-5746

WILLIAM PATTERSON RV SALES LTD.
R.R. # 1
Dutton, ON N0L 1J0
(519)762-2125 Fax (519)762-3386

QUEBEC

RAYMOND LE BLANC INC.
1275 Des Laurentides Boulevard
Vimont Laval, PQ H7M 2Y2
(514)663-7941 Fax (514)663-2213

SASKATCHEWAN

DJ'S RV CENTRE LTD.
Thatcher Dr. E. & #1 Highway, P.O. Box 308
Moose Jaw, SK S6H 4N9
(306)694-6048 Fax (306)694-1221

CHAPTER 2

TOWING AND SAFETY PRECAUTIONS

Table of Contents

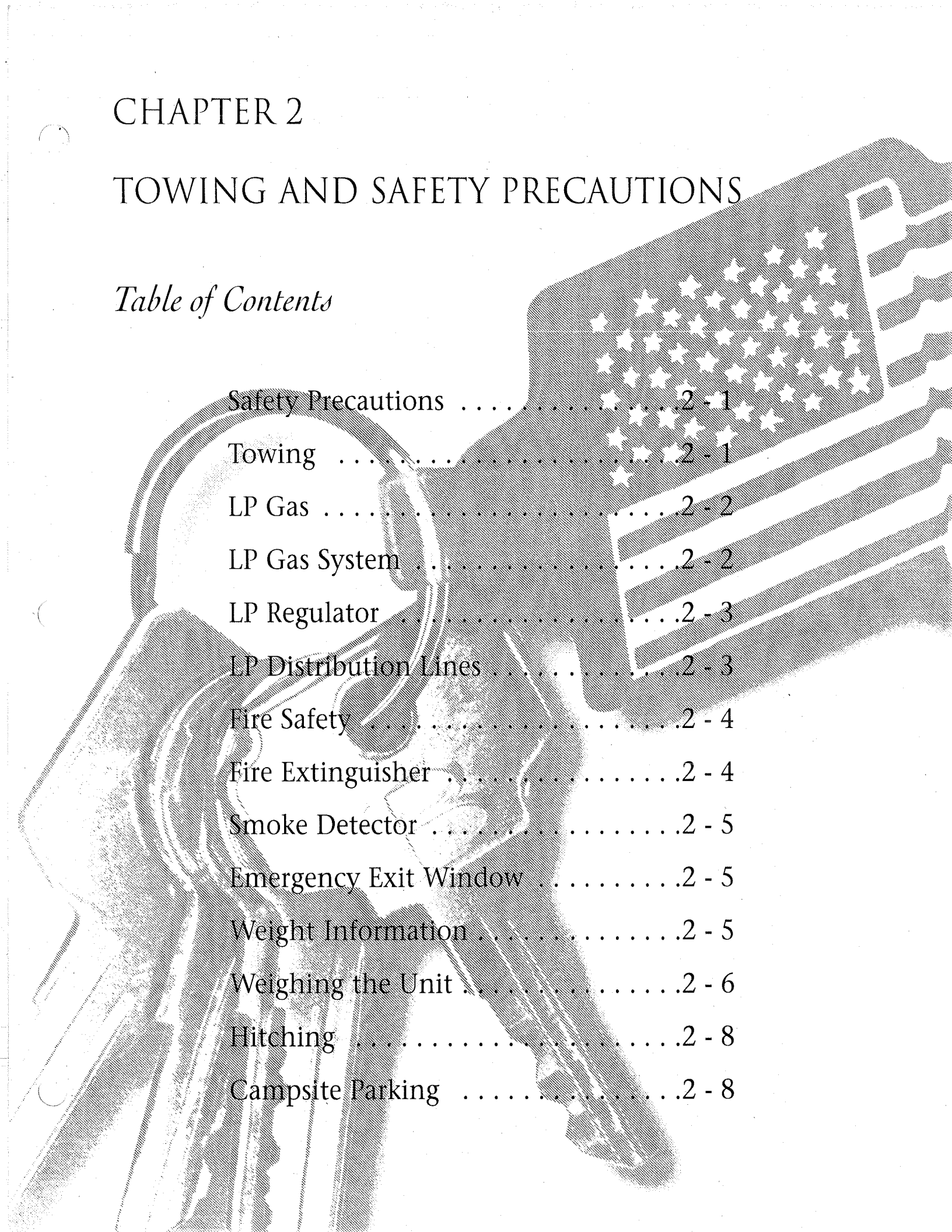

Safety Precautions	2 - 1
Towing	2 - 1
LP Gas	2 - 2
LP Gas System	2 - 2
LP Regulator	2 - 3
LP Distribution Lines	2 - 3
Fire Safety	2 - 4
Fire Extinguisher	2 - 4
Smoke Detector	2 - 5
Emergency Exit Window	2 - 5
Weight Information	2 - 5
Weighing the Unit	2 - 6
Hitching	2 - 8
Campsite Parking	2 - 8

SAFETY PRECAUTIONS

WARNING

Prior to towing your vehicle, be sure you have read this entire owner's guide and that you understand your vehicle's equipment completely and how to use the equipment safely.

Read and understand all of the instructions and precautions in this owner's guide before towing your new fifth wheel. Listed below are some safety precautions that must be adhered to while your vehicle is in motion. These precautions, as well as others that involve possible damage to equipment, are also listed in the appropriate areas in this manual.

General Warning

WARNING

Portable fuel-burning equipment, including wood and charcoal grills and stoves, shall not be used inside the recreational vehicle. The use of this equipment inside the recreational vehicle may cause fires or asphyxiation.

- The fire extinguisher should be inspected monthly for proper charge and operating condition. The smoke alarm should also be tested on a regular basis. In addition to the recommended inspection, these should also be checked prior to a vacation or extended trip.
- Any part of this vehicle, including the sleeping facilities, must not be used while the vehicle is in motion. It is not safe to ride in a towed vehicle and in most states it is illegal.
- Become familiar with the operation of the escape window, but use this window strictly as an emergency exit.

Towing

- While driving on slippery surfaces, use care when accelerating or decelerating. Skidding and loss of vehicle control may be the result of abrupt changes in speed.
- Driving through water deep enough to wet the brakes may affect the stopping distance or cause the vehicle to pull to one side. If you have driven through deep water, check the brake operation in a safe area to be sure they have not been affected. Never operate a vehicle if a difference in braking efficiency is noticeable.
- Extreme terrain and adverse weather may affect the handling and/or performance of your vehicle.

regulator yourself. Have an authorized service technician make any necessary adjustments. We recommend that you have the LP gas system checked by an authorized service technician at least once a year, and after every extended trip. Although the manufacturer and dealer test carefully for leakage, travel vibrations could loosen fittings. Leaks can be easily found by applying leak detector solutions at the connections. If leak detector solution is not available, a soapy water solution made with dish soap can be used. Tightening the fitting usually stops any leaks. If this does not work, shut off the main gas valve at the tank and immediately consult an authorized technician for repairs. If a leak is suspected, the identifying order smells similar to rotten eggs (sulfur). Never test for a leak by lighting a match or have an open flame where you suspect leaking gas.

WARNING

Shut off the main gas valve at the tank when the camping vehicle is not in use. Also, shut off the valve when refueling to avoid potential danger from pilot lights igniting fuel fumes. Some appliances, such as the refrigerator, water heater, and furnace, have DSI (direct spark ignition) boards so it is important that you turn the appliances off when the LP gas is off. The ignition in the appliances will continue to spark even if there is no LP gas available.

LP Regulator

The regulator acts as the heart for the LP gas system. The LP gas in the tank is under high pressure. The regulator reduces the pressure of this gas so that it is safe to use with the various appliances in your unit. If corrosion is noticed, contact a qualified LP gas service technician. Do not adjust the regulator. It is factory preset. Adjustments are to be made by a qualified LP service technician using specialized equipment.

LP gas regulators must always be installed with the diaphragm vent facing downward. Regulators that are not in compartments have been equipped with a protective cover. Make sure that the regulator vent faces downward and that the cover is kept in place to minimize the vent blockage that could result in excessive gas pressure causing fire or explosion.

Distribution Lines

The primary manifold is a black steel pipe running the length of your unit. Most secondary lines leading to gas appliances are made of copper tubing with flare fittings. If any of the gas lines rupture, do not attempt to splice them. Always run a new line. We recommend gas distribution work be performed by an authorized service technician. The main valve at the LP tank must be closed when removing or servicing any gas appliance. This will prevent dangerous gas leakage that could result in an explosion and possibly serious injury. If a leak is suspected, have the systems inspected and repaired by a qualified service technician.

Smoke Detector

The battery powered smoke detector is mounted on the ceiling in the living area of the unit. Read the operating instructions for details on the testing and care for this important safety device. Test the smoke detector after the unit has been in storage, before each trip, and at least once a week during use. The detector should never be disabled because of nuisance or false alarm from cooking smoke or a dusty furnace. Ventilate the unit with fresh air and the alarm will shut off. Never disconnect or remove the battery from the smoke alarm. The battery should be replaced once a year or when the low battery signal sounds.

Emergency Exit Window

In the bedroom or slide out of the unit, there may be an emergency exit (egress) window. This window is designed to be used as an additional exit in emergency situations. It can be easily identified by the red handle and the red "EXIT" label. To open the egress window, lift the handle and push outward on the window. The window can be closed by pulling the window shut and lowering the handle in the down or locked position.

WEIGHT INFORMATION

Below is a sample of a weight information label which may appear in your unit.

TOWABLE WEIGHT INFORMATION	
Newmar Unit Number _____	SAMPLE
Model _____	
GVWR _____	
UVW _____	
NCC _____	
GVWR (Gross Vehicle Weight Rating) means the maximum permissible weight of this trailer. The GVWR is equal to or greater than the sum of the Unloaded Vehicle Weight plus the Net Carrying Capacity.	
UVW (Dry or Unloaded Vehicle Weight) means the weight of this trailer as built at the factory. If applicable, it includes full generator fuel, engine oil, and coolants. The UVW does not include cargo, fresh water, LP gas, or dealer installed accessories.	
NCC (Net Carrying Capacity) means the maximum weight of all personal belongings, food, fresh water, LP gas, tools, dealer installed accessories, etc., that can be carried by this trailer. (NCC is equal to or less than GVWR minus UVW)	
This trailer is capable of carrying up to _____ gallons of fresh water (including water heater) for a total of _____ pounds. Reference: Weight of fresh water is 8.33 lbs/gal, Weight of LP gas is 4.5 lbs/gal (average).	
CONSULT OWNER'S MANUAL FOR SPECIFIC WEIGHING INSTRUCTIONS AND TOWING GUIDELINES.	

Fifth Wheels

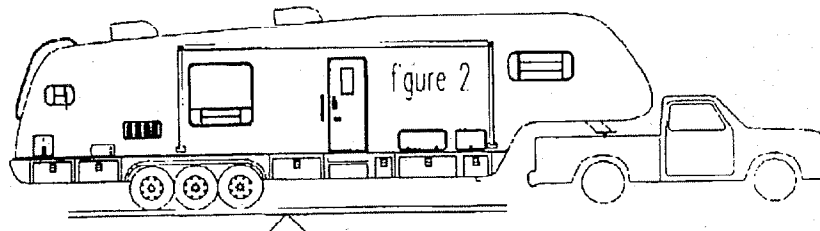
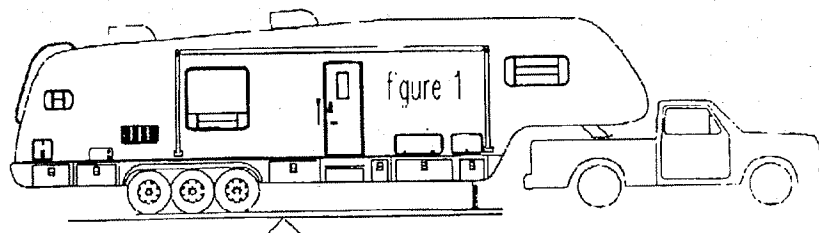

1. Pull the unit onto the scales shown in Fig. 1. This is the total weight of the unit. To do this, put the front jacks down far enough to take all of the weight off of the tow vehicle and onto the scales. Make sure that only the trailer is on the scales. Record the weight. This is the GVW and should not exceed the GVWR supplied by Newmar for the unit.
2. Hook up to the unit and be sure, again, that there is no part of the tow vehicle on the scales as shown in Fig 2. Weigh the unit with only the trailer tires on the scales. Record the weight. This is the total weight on the axles. When this amount is subtracted from the GVW (first reading), the difference is the hitch weight. To achieve the approximate weight on each axle, divide the weight from Fig. 2 by the number of axles. This amount should not exceed the GAWR of the unit. For example 9,360 pounds with 2 axles is 4,680 pounds per axle or approximately 2,340 pounds per tire.

Notes

CHAPTER 3

AIR CONDITIONING & HEATING

Table of Contents

Air Conditioning	3 - 1
Furnace	3 - 2
LP Bottles	3 - 3
LP Bottle Filling	3 - 3
LP Regulator	3 - 4
LP Detector	3 - 4

AIR CONDITIONER(S)

The roof mounted central air conditioner installed on your unit will operate only when the unit is supplied with 120 volt AC power from the power cord or the optional generator. The air conditioner circuit breaker must be in the "ON" position to work. The air conditioner installed on this unit is equipped with an electric heat strip. This is used to take the chill off the unit or any time a little warmth is needed. Depending upon which option package was installed, the unit may be equipped with two air conditioners.

Park the vehicle in the shade with the drapes or blinds closed for the best performance. Set the thermostat to the desired temperature while keeping the doors and windows closed. Keep in mind that air conditioners use a large portion of the available electric power.

RV parks may experience low voltage on days with high heat or humidity. This is commonly referred to as a "brown out". A brown out may trip the air conditioner circuit breaker. The circuit breaker protects your air conditioner motor from damage and is necessary during low voltage conditions. The tripping breaker is not a fault in your electrical system.

The cool air from the air conditioner is ducted throughout the coach through the cool air ceiling ducts. Warm air is returned to the air conditioner through return air ceiling ducts. Below is the thermostat that controls the air conditioner. It also controls the furnace. Simply select the desired temperature. The blower will cycle automatically, or you may choose low, medium or high fan settings.

Step One: Move power switch to ON

Step Two: Press MODE button to select function. (COOL*, FURNACE, FAN ONLY, etc.)

* There is an approximate 2-minute time delay after selecting cooling function for refrigerant compressor to start.

Step Three: Press FAN button to select fan speed or automatic operation.

Step Four: Press UP or DN button to set your desired temperature for the zone.

Step Five: If your vehicle contains more than one zone, depress FAN and MODE simultaneously to select zone 2, and repeat procedures from step 2 above. Repeat entire procedure for each additional zone.

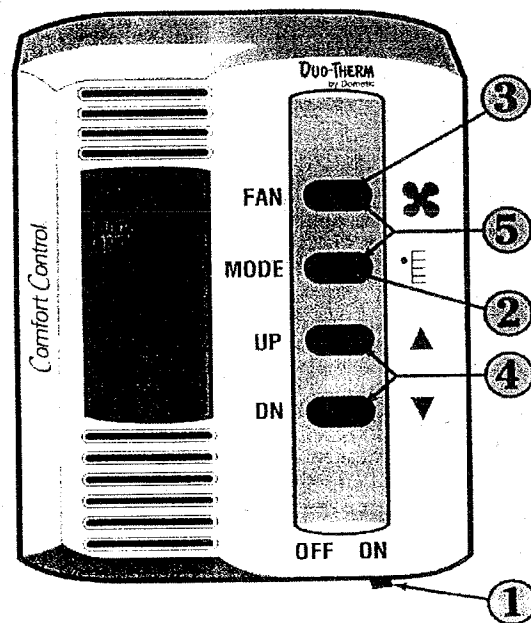

Shutdown: If you turn the Comfort Control off, or if there is a power interruption for any reason, the system will resume operation on the last settings when power returns.

WARNING

Portable fuel burning appliances are not safe for heating inside the recreational vehicle. Asphyxiation or carbon monoxide poisoning can occur.

LP BOTTLES

This unit is equipped with two 30# LP bottles. These bottles are controlled with an automatic pressure regulator. The LP bottles contain liquid petroleum gas under high pressure. As the fuel is used, the liquid gas vaporizes and passes through the tank valve to a regulator that automatically reduces the pressure. The low-pressure gas is then distributed to the appliances throughout the pipe manifold system. Improperly adjusted regulators are the major cause of appliance lighting problems. Never attempt to reset the regulator. This is to be done by a qualified service technician. While in high altitudes or extreme cold weather a gas shortage may be experienced. Using one appliance at a time can help adjust to this problem.

It is recommended to have the LP system inspected by an authorized service technician at least once a year and after every extended trip. This system is tested by both the manufacturer and the dealer. Leaks can be caused by travel vibrations, therefore routine inspections are recommended.

The primary gas manifold is a black steel pipe running the length of the unit. All secondary lines leading to the gas appliances are made of copper tubing with flare fittings. If any of these lines rupture do not attempt to splice them. Always have a new line ran. Gas distribution work must be performed by an authorized service technician. When removing or servicing any gas appliance, close the main gas valve at the LP bottles. This will prevent dangerous gas leakage that could result in an explosion and possible serious injury. If a gas leak is suspected, have the system inspected and repaired by a qualified service technician as soon as possible.

WARNING

The main gas valve must be shut when the vehicle is not in use. Shut the valve off when refueling to avoid potential danger from pilots lights igniting fuel fumes. Gas valves on appliances with direct spark ignition (DSI) should also be in the off position. Do not store LP, gasoline, diesel, or other flammable liquids inside the vehicle. Fire or an explosion could be the result of ignoring this warning.

LP Bottle Filling

Do not fill the bottles to more than 80 percent of capacity. Fire or explosion may be the result of uncontrolled gas flow from an overfilled tank.

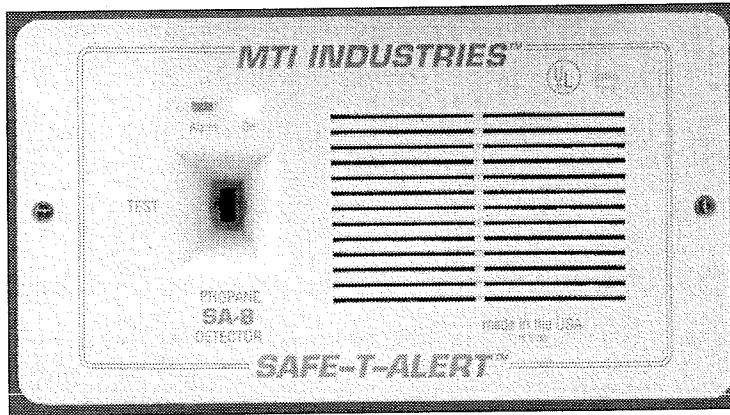

Your Safe-T-ALERT LP detector is designed to be easy to operate. The detector has an indicator light that constantly monitors the condition of the detector and signals the user by displaying a specific color;

The YELLOW WARM UP LED light will glow for about 80 seconds then the LED will turn green. Once power is supplied, the GREEN power ON indicator light should glow continuously. If the indicator light does not light, turn off the power and check all wire connections. If the power is on and connections are correct but the indicator still does not light, the detector should be returned for service.

A GREEN color indicates an "ON" or normal condition; the LP detector has power and is sensing the air for the presence of LP gas. The alarm horn will not sound.

A YELLOW color indicates a "TROUBLE" or malfunction condition; the alarm horn will sound and cannot be reset by the TEST/RESET button. The LP detector is not working properly and must be immediately replaced or repaired.

A RED color indicates an "ALARM" condition; the detector has sensed dangerous levels of propane. The alarm horn will stay ON as long as dangerous levels of propane are present. Extinguish all flames (burners, heaters, smoking materials, etc.) and turn off all propane appliances in the area. The area should be immediately evacuated and ventilated. Turn off the propane tank valve and determine the source of the leak. Seek professional help if necessary.

Please consult your LP detector User's Guide for more detailed information.

Notes

CHAPTER 4

APPLIANCES & ACCESSORIES

Table of Contents

Refrigerator	4 - 1
Microwave	4 - 2
Range Hood	4 - 2
Range	4 - 2
Television Antenna	4 - 3
Television	4 - 4
Video Control Center	4 - 4
Video Cassette Recorder	4 - 5
Cable Jack	4 - 5
Telephone Jack	4 - 5
Stereo	4 - 5
Water Heater	4 - 6
Water Heater Storage	4 - 6
Water Heater Relief Valve	4 - 7
Washer/Dryer	4 - 7
Ceiling Fan	4 - 7

MAJOR APPLIANCES

Refrigerator

Before starting the refrigerator, verify that the main LP gas valve is in the on position. The refrigerator is equipped with a semi-automatic energy selector (AES) control system. It can be set to select either 120 volt or LP gas operation, automatically, if desired.

WARNING

Most LP gas appliances used in recreational vehicles are vented to the outside of the vehicle. When parked close to a gasoline pump it is possible that the gasoline fumes could enter this type of appliance and ignite the burner flame causing a fire or explosion. Use caution when refueling.

A 12 volt power supply must be available for the electronic control panel to function. The shore line must be plugged in, or the optional generator running, to operate in the 120 volt mode. The main LP gas valve must be open for operation in the LP mode. To start the refrigerator, press the main power ON/Off button to the ON position.

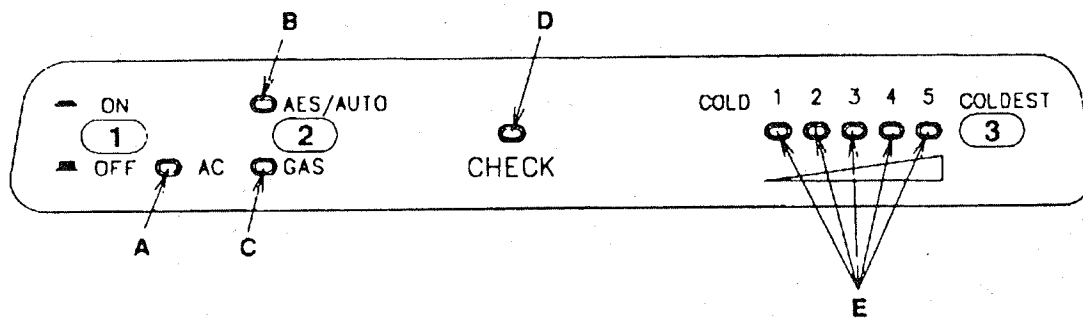

LEGEND 2-WAY AES Model

1. Main Power Button ON/OFF
2. AES/AUTO/GAS Mode Selector Button
3. Temperature Selector Button

- A. AC Mode Indicator Lamp
- B. AES/AUTO Mode Indicator Lamp
- C. GAS Mode Indicator Lamp
- D. CHECK Indicator Lamp
- E. Temperature Indicator Lamps

To use the 2-way Auto Mode, push the AUTO/GAS mode selector into the ON position. If 120 volt is available, the AC mode indicator light will be illuminated designating AC operation. If 120 volt is not available, the gas mode indicator light will be illuminated. The control system will automatically switch to gas operation. To operate on gas only, push the AUTO/GAS mode selector until the gas indicator light has lit. After 45 seconds, the burner should be ignited and operating normally. The initial start up may take longer than 45 seconds in order to allow the air to be purged from the gas line. If the gas does not ignite within 45 seconds, the check indicator light will illuminate and the gas mode light will go off. If the check indicator light illuminates and the gas mode indicator light is off, then the controls have failed to ignite the burner in the gas mode. When the check indicator light is on, press the main power ON/OFF button to the off position to reset. Do not continue to reset the gas operation if the check indicator light continues to illuminate after several tries.

Unlike homes, the amount of oxygen supply is limited due to the size of the recreational vehicle. Proper ventilation when using the cooking appliance(s) will avoid dangers of asphyxiation. It is especially important that cooking appliances not be used for comfort heating as the danger of asphyxiation is greater when the appliance is used for long periods of time.

The following label has been placed in the vehicle near the range area:

If You Smell Gas:

1. Extinguish any open flames, pilot lights, and all smoking materials.
2. Do not touch electrical switches.
3. Shut off the gas supply at the tank valve(s) or gas supply connection.
4. Open doors and other ventilating openings.
5. Leave the area until the odor clears.
6. Have the gas system checked and leakage source corrected before using again.

TELEVISION OPERATION

Winegard Television Antenna

The TV antenna in your unit is designed for reception of all color and black-and-white channels. If the reception is poor, you should verify that the power switch is in the "ON" position and that all of the connectors are tight. If poor reception still occurs, consult your authorized dealer.

To raise the antenna into the operating position, turn the elevating crank (clockwise) in the "UP" direction, about 13 turns, or until some resistance to turning is noticed. On the power booster, turn the switch to "ON" in order to amplify the signal being received. Once in the "UP" position, rotate the antenna to receive the best picture. This is done by pulling down on the directional handle with both hands until it disengages from the ceiling plate and then rotating it until reception has improved. The antenna must be lowered before moving the vehicle. To lower, rotate the directional handle until the pointer is aligned with the pointer on the ceiling plate. Turn the elevating crank (counter-clockwise) in the "DOWN" direction, about 13 turns, or until some resistance to turning is noticed. The antenna is now locked and in the travel position.

RAISING ANTENNA TO OPERATING POSITION

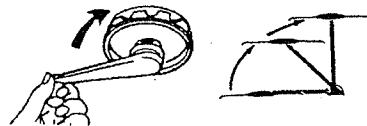

ROTATING ANTENNA FOR BEST PICTURE



LOWERING ANTENNA TO TRAVEL POSITION

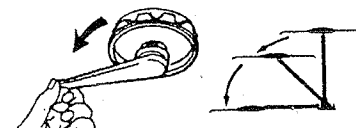

CAUTION

Under no circumstances should you lower the antenna in any position except the travel position.

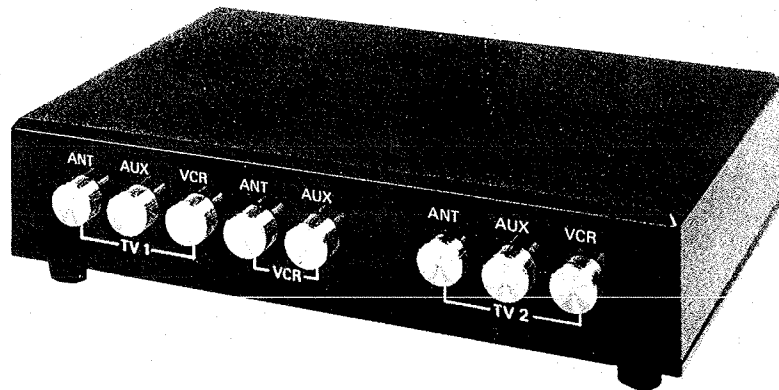

Video Cassette Recorder

The video cassette recorder (VCR) is installed in your unit as standard equipment. It is in the living room entertainment center. The controls are on the face of the VCR and on the remote control. For more detailed information regarding the VCR functions consult the VCR Operator's Manual in the Owner's Package. The video switch described above will assist you in directing the VCR signal to the television of your choice.

Cable and Telephone Jack

An extra interior cable television jack is available on your unit. The exterior jack for use on the door side of the unit is installed as standard. A standard feature on this unit is the telephone hook up. This feature includes the connector for the incoming telephone line and one telephone outlet inside the unit. As an option, an additional telephone outlet may be installed.

Stereo

The standard stereo installed in your unit is an AM/FM Cassette player. There are speakers located throughout the unit for listening pleasure. The operation of the stereo is similar to that of many car stereos. It operates on 12 volt electricity from the coach batteries. For further information on the operation of this stereo, consult the stereo Owner's Manual in the Owner's Package.

When preparing the unit for use after it has been stored, make certain the water system, including the water heater has been filled before re-lighting the water heater. Failure to fill the water heater before lighting may damage the water heater and void the warranty.

Pressure Relief Valve

The temperature and pressure relief valve is designed to open if the temperature of the water within the heater reaches 210 F, or if the water pressure in the heater reaches 150 pounds. Recreational vehicle water systems are closed systems and during the water heating cycle the pressure build-up in the water system may reach 150 pounds. When this pressure is reached, the pressure relief valve will open and water will drip from the valve. This dripping will continue until the pressure is reduced to below 150 pounds, and the valve closes. This condition is normal and does not indicate a defective relief valve.

WARNING

Do not plug the relief valve under any circumstances.

Washer/Dryer (Optional)

The plumbing and/or the installation of a washer and dryer is part of the various option packages available on your unit. The washer and dryers used by Newmar function as those in a home, operating on 120 volt electricity. For more detailed information on the operating instructions, read the appliance Owner's Manual in the Owner's Package.

Ceiling Fan

In the living room area you will find the standard ceiling fan. This operates on 120 volt electricity. The fans three speeds (low, medium and high) can move air in two directions, up and down. By moving the air up in the summer months, the fan will help circulate the cool air from the air conditioner. By moving the air down, the fan will help circulate the warm air from the furnace in the winter months.

Notes

CHAPTER 5

CABINETS & FURNITURE

Table of Contents

Cabinets	5 - 1
Furniture	5 - 2
Living Room Area	5 - 2
Bedroom Area	5 - 2

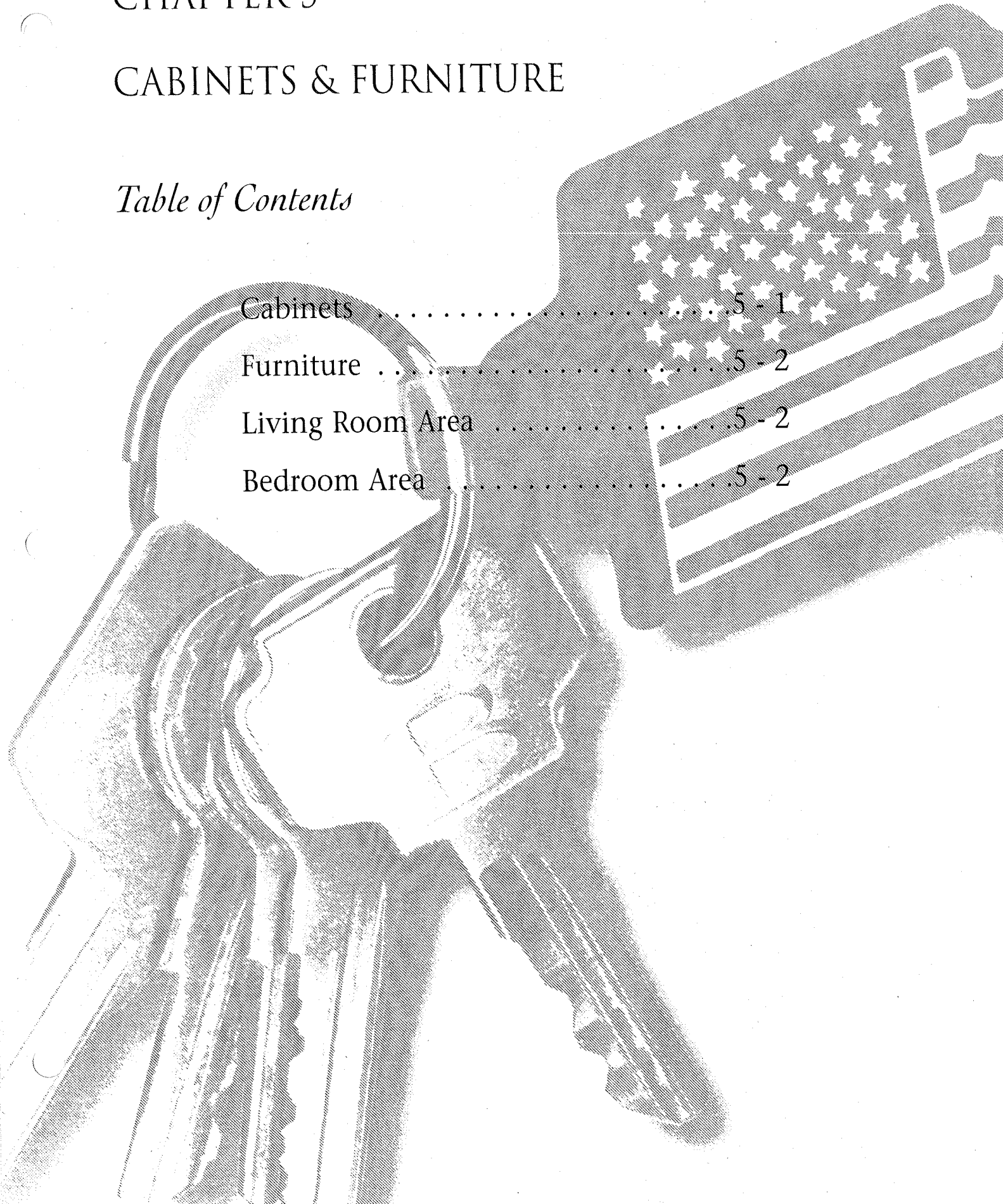

CABINETS

The cabinets in this unit are constructed on site, at the Newmar production facility. Cherry cabinetry and cherry frame doors with cathedral style raised panels are standard throughout the unit. There are two decor options regarding the cabinetry. They are oak and bleached oak. All decors have brass door and drawer pulls. These give the interior an added touch of class. The glass door panels in the living room entertainment center allow for viewing the lighted mirrored interior of the cabinets.

The Corian countertop extension in the kitchen provides additional counter space while cooking, and folds out of the way while entertaining. Consult the manufacturer's care instructions on the Owner's Information card in the Owner's Package provided with this unit. The silverware drawer contains a molded silverware divider tray for added storage.

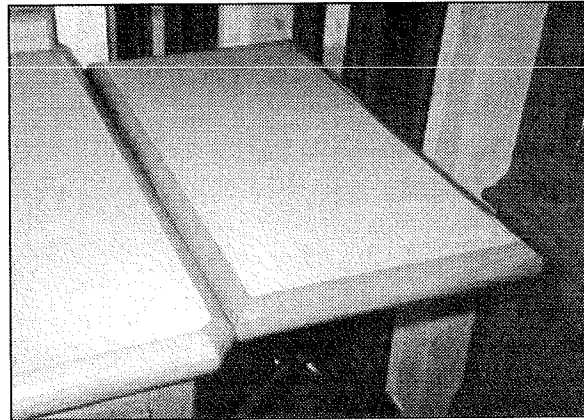

Storage is an important factor to all RV owners. Keeping this in mind, the cabinetry is structured to provide as much storage as possible. Some models have pantry style cabinets in the kitchen for added storage. In the bedroom on all models, the bed platform lifts for convenient storage. This platform is held open by gas struts to allow hands-free access.

The countertop in the kitchen and bath is made of a decor matching Corian. The "drawer" directly in front of the kitchen and lavatory sink does not pull out, but rather flips down. This provides a storage tray for dish cloths, scouring pads, wash cloths, etc.

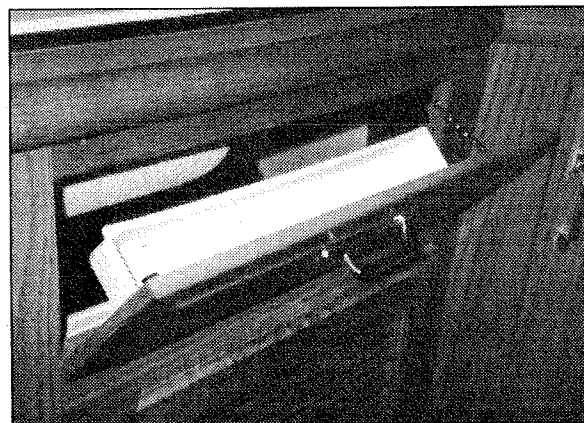

Drawer guides are standard on all of the drawers throughout the unit. These guides provide a smooth opening and closing of the drawers. To open a drawer, lift up slightly and pull open. The way this mechanism works will prevent the drawers from unintended opening while traveling. The drawers are constructed with maple panel bottoms for added strength. All of the cabinets are equipped with positive door catches and knife hinges. The catches secure the door in the closed position for extra security when traveling.

All of the cabinetry can be easily cleaned with any commercial furniture cleaner or polish. As with any wood product, do not saturate these cabinets with water or any other liquid. Be sure to wipe up spills as they occur to avoid staining.

CHAPTER 6

STRUCTURE FEATURES

Table of Contents

Frame Features 6 - 1

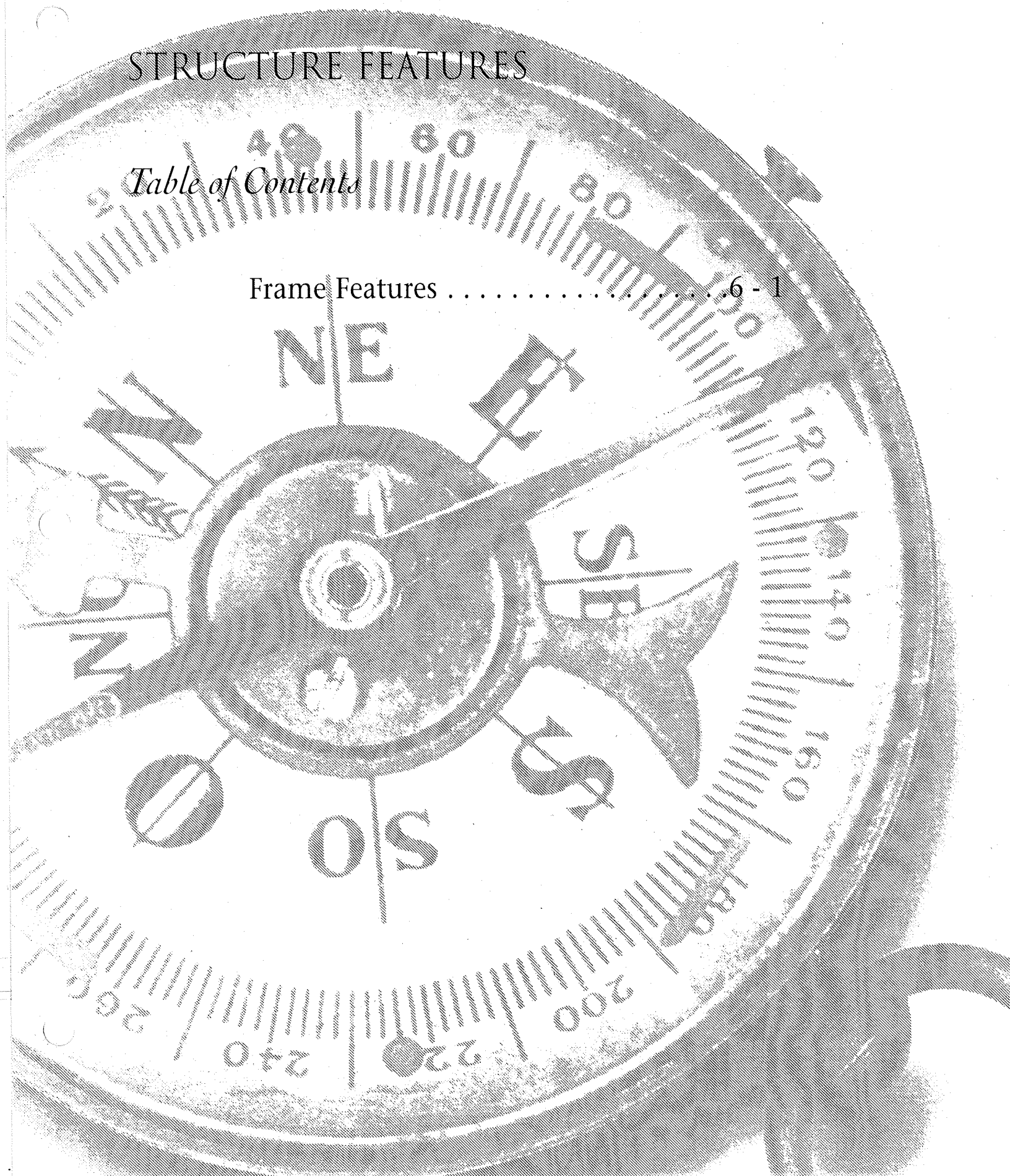

STRUCTURE FEATURES

All models have 16" steel I-Beam frame construction with a fiberglass wrap for maximum storage capabilities. These frames are manufactured at the Newmar production facility. Doing this ensures the control of quality that Newmar insists upon.

Skid bars are installed on all models as a standard feature. These will help prevent accidental damage when encountering dips or steep inclines.

The tires installed on the unit are 16" radials. The spare tire is a standard feature on this unit. The aluminum wheels installed on these units measure 16" x 6". The bolt pattern on the wheel is 8 on 6½". The brake size is 12¼" x 3⅜" while the axle capacity is 7,000 pounds.

As part of standard equipment, all units have the Mor/Ryde suspension system with heavy duty shock absorbers. This will help cushion the fifth wheel when going over rough, uneven roads. In addition, they assist in stabilizing the unit.

CHAPTER 7

ELECTRICAL FEATURES

Table of Contents

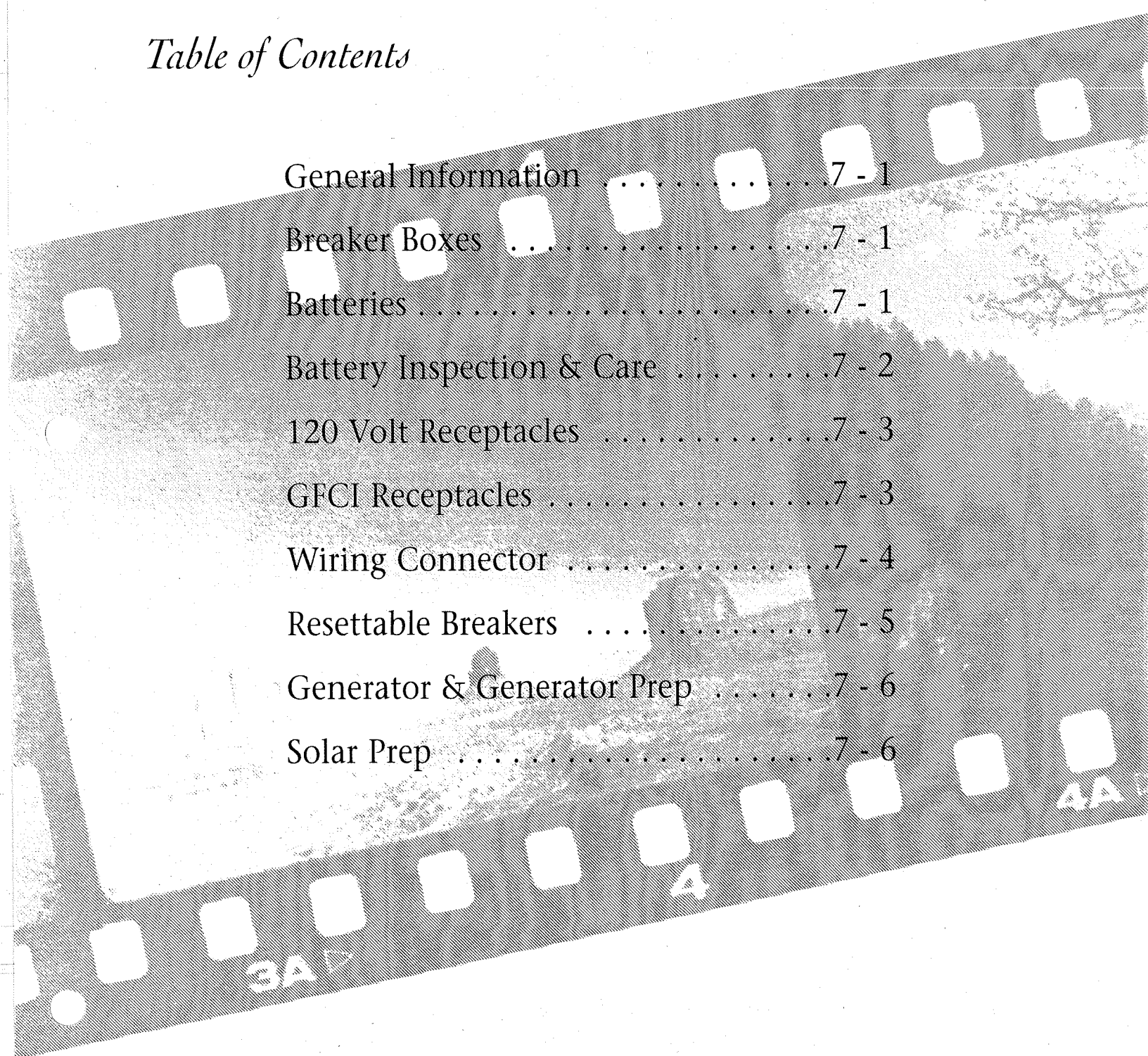

General Information	7 - 1
Breaker Boxes	7 - 1
Batteries	7 - 1
Battery Inspection & Care	7 - 2
120 Volt Receptacles	7 - 3
GFCI Receptacles	7 - 3
Wiring Connector	7 - 4
Resettable Breakers	7 - 5
Generator & Generator Prep	7 - 6
Solar Prep	7 - 6

ELECTRICAL SYSTEMS

General Information

There are two electrical systems in your coach. They are the 12 volt DC system and the 120 volt AC system. Most standard appliances require the 120 volt system while the majority of the lighting used in recreation vehicles is powered by 12 volt. The power for the 12 volt system is supplied by the coach batteries. The power for the 120 volt systems is supplied by the power cord when the unit is connected to an outside power source or by the generator, if so equipped. When connected to shore power, the standard 75 amp power converter will automatically charge the batteries as well as convert 120 volts into 12 volts.

To connect the unit to 120 volt shore power, first make sure all of the breakers are in the off position. This is done to avoid a power surge. Unwind the power cord from the electrical compartment. The standard electrical service in this unit is 50 amps with a flexible 50 amp power cord. Check to make sure the pins in the outlet are oriented correctly, that they match the power cable, and that they are in good condition. If there is a circuit breaker switch at the plug, it should be turned OFF before making the connection. Insert the plug completely into the outlet and turn the circuit breaker on. Close, and lock the electrical compartment door to keep the contents clean, dry, and secure. Close the cover on the power box, if equipped, to avoid an unintended disconnection, and to keep contents clean. Switch the main breaker to the 'ON' position. The 120 volt system will energize all 120 volt circuits and outlets when the main breaker is turned on.

Breaker Boxes

The 120 volt and 12 volt breaker boxes are generally installed in a bedroom cabinet. Circuit breakers and fuses are installed to protect the electrical system from overloading. Do not attempt to change the circuitry or add appliances yourself. Please consult an authorized Newmar Service Center.

Batteries

Two batteries are standard on your unit. An additional battery can be installed as an optional feature in this unit. The batteries are installed by Newmar, but are warranted by the battery manufacturer. They are used to operate the 12 volt items in the unit. The batteries also operate the water heater's electronic ignition, landing jacks, etc. The in-line breakers protecting these circuits are found near the batteries. If the tow vehicle is equipped with a charge line, the tow vehicle's electrical system will charge the coach battery while in transit. The power converter automatically charges the coach batteries when the unit is connected to a 120 volt outside power source.

120 Volt Receptacles

For your convenience, there are 120 volt receptacles located throughout the interior of the unit. There are also exterior outlets located on the curbside of the coach. These receptacles require the three-pin plugs that provide proper grounding to protect you from electrical shock. Do not use an adapter, cheater, or extension cord that breaks the continuity of the ground circuit to the ground pin. Never remove the ground pin from a plug in order to connect it to a two pronged ungrounded outlet. Never operate the camping vehicle with an electrical short. An electrical short may cause the exterior of the unit to shock you when touched. If you feel even the slightest shock, disconnect the unit from the 120 volt power source and locate the fault. It is usually a break in the grounding circuit. The grounding circuit must be continuous from the frame to the distribution panel, to the power cord, to the earth ground.

Ground Fault Circuit Interrupt Receptacle

The 120 volt electrical outlets in the kitchen and bath area are ground fault circuit interrupt (GFCI) receptacles. The GFCI outlets provide an overload and short circuit protection. The electrical outlets located in the slide out are wired through the kitchen GFCI. The exterior electrical outlets are wired through the bathroom GFCI. If an item plugged into a slide out or outside receptacle is not working, check for a tripped GFCI in the kitchen or bathroom. In addition, these outlets protect the user from ground faults between a hot wire and ground. The GFCI will not reduce the shock hazard if the short is between a neutral and hot wire, or two hot load wires.

The GFCI should be tested at least once a month. The 120 volt electrical system must be on in order to test the GFCI. The reset button needs to be pushed in all of the way before starting the test. Push the test button. This will cause the reset button to pop out which means that the protected circuits have been disconnected. Push the reset button back in until a click is heard. This will reactivate the protected circuit. If the GFCI is working properly the reset button will remain in the 'IN' position.

Electrical Diagrams

Typical electrical diagrams can be found in chapter 15.

Notes

RESETTABLE BREAKERS

The resettable breakers are located within 18 inches of the source of power. This is the converter and the battery. (Figure 1)

When either of the breakers are shut down they must be manually reset.

To find the breakers, follow the line from the battery or converter approximately 18 inches.

This may lead to a junction box or to a cabinet inside the unit or similar location.

Manually reset the breaker as shown at right in Figure 2.

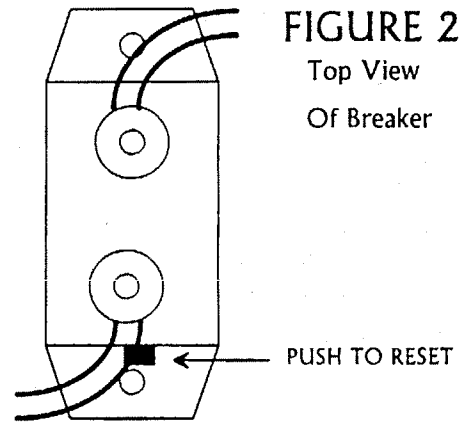
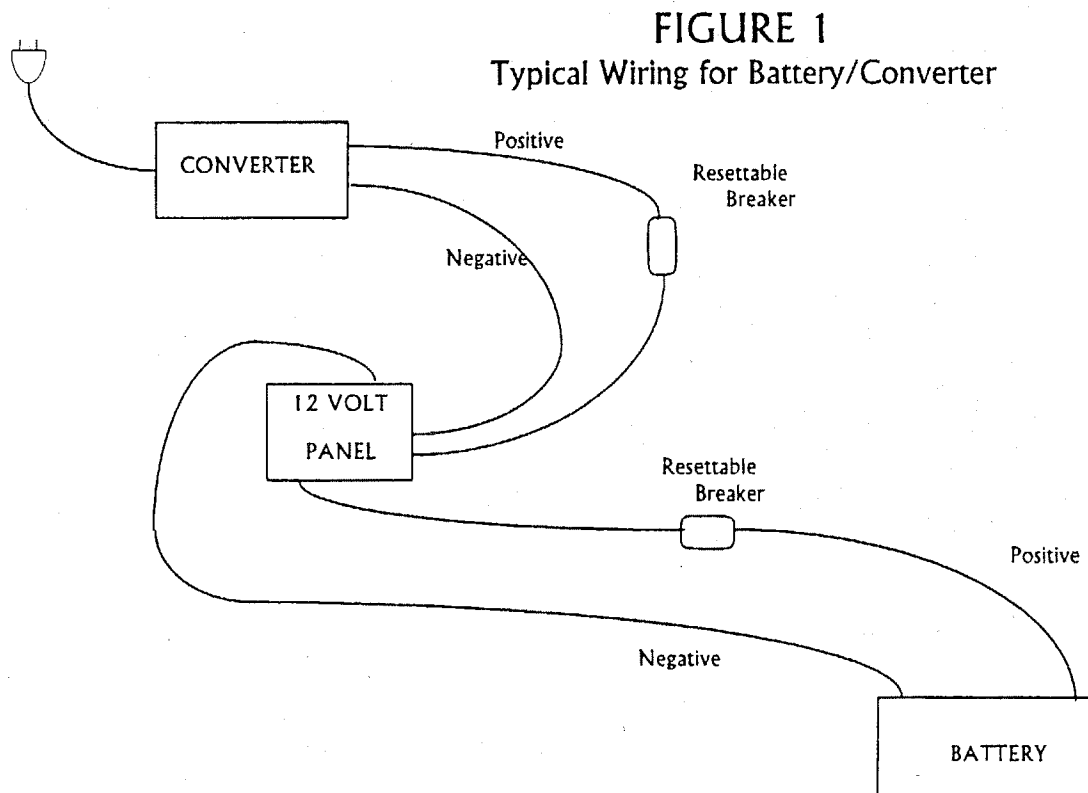

FIGURE 2
Top View
Of Breaker



CHAPTER 8

SLIDE OUT FEATURES

Table of Contents

General Instructions	8 - 1
Extending	8 - 2
Retracting	8 - 2
Manual Operation	8 - 2
Operating Precautions	8 - 3

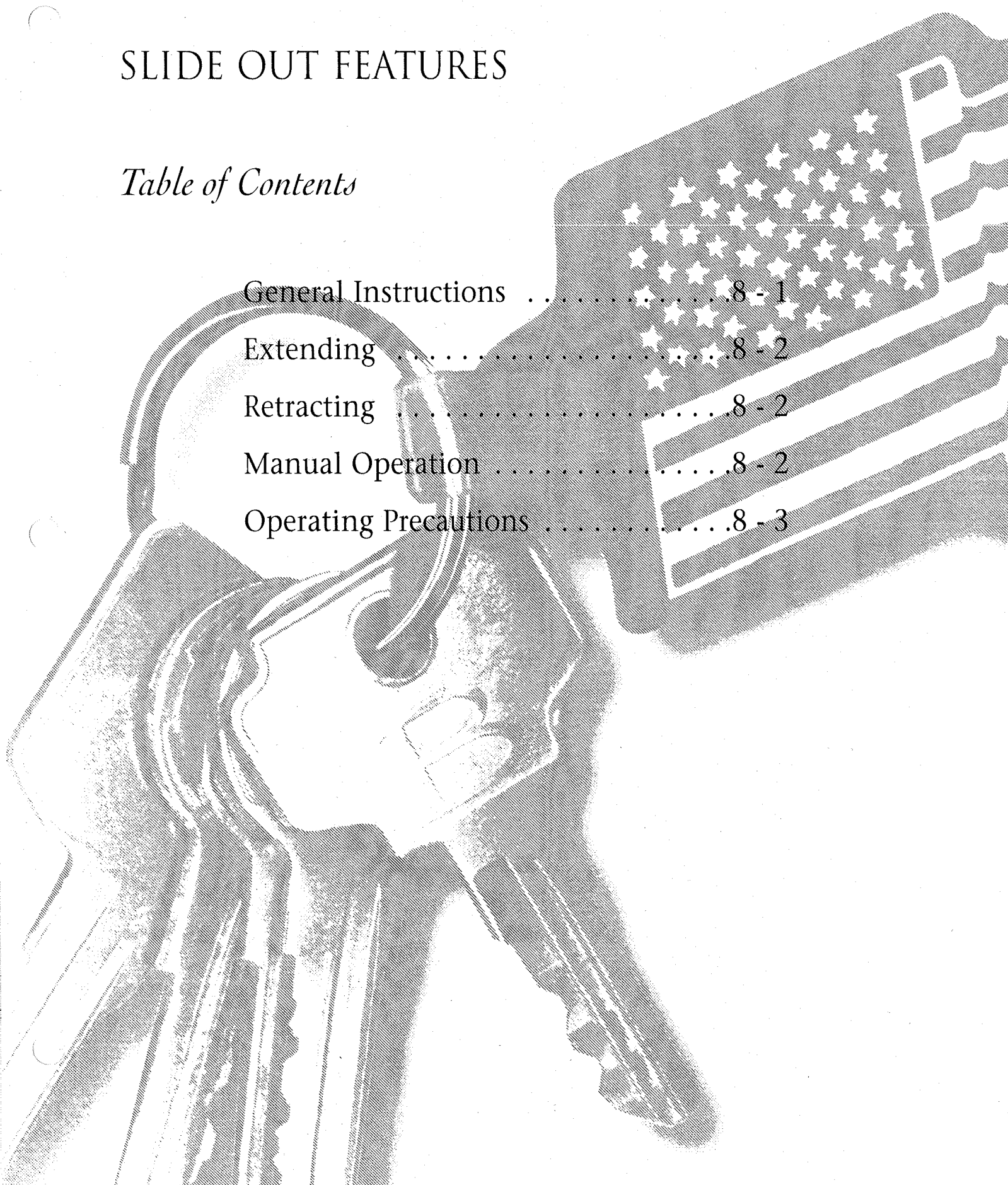

WARNING

READ THE FOLLOWING SLIDE OUT ROOM INSTRUCTIONS BEFORE ACTIVATING THE SWITCH.

IMPORTANT

The slide out room should be inspected for alignment every six (6) months. If alignment is necessary, have the room adjusted.

GENERAL INSTRUCTIONS

1. The slide out room can be stopped at any time by activating the slide out switch. The room will reverse directions each time the switch is activated.
2. If the slide out room stops before reaching the full 'OUT' or 'IN' position, the slide out controller may need adjustment.
3. To adjust the slide out controller, turn the adjustment screw clockwise to increase the power and counter-clockwise to decrease the power.

CAUTION

Move the adjustment screw in small increments. Try moving the slide out room again. Use caution. There is a potential for component or structural damage if the screw is adjusted too high.

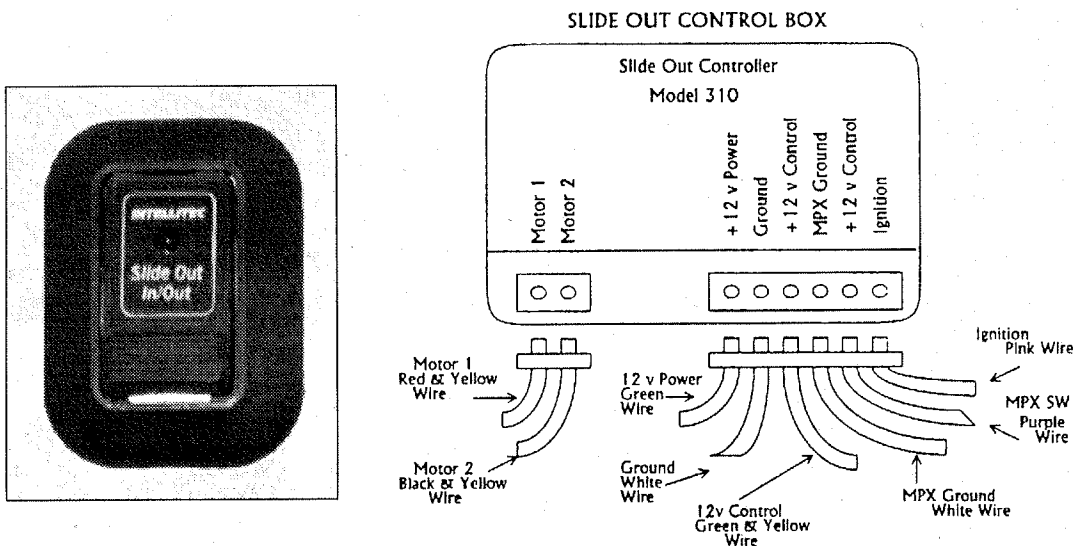

IMPORTANT

This screw does not adjust the slide out room speed. It sets the amount of power required to move the room against the mechanical stops.

CHAPTER 9

EXTERIOR FEATURES

Table of Contents

Exterior Sides	9 - 1
Jacks	9 - 1
Stabilizer Jacks	9 - 2
Roof	9 - 2
Steps	9 - 2
Electric Steps	9 - 3

EXTERIOR FEATURES

Exterior Sides

The sides of this unit are constructed of gel-coated fiberglass. To add to this feature, the front and rear end caps are also gel-coated fiberglass. Clean the fiberglass material with a mild cleanser and warm water. Use only soft cloths. Using stiff bristle brushes may cause scratches in the fiberglass surface.

Jacks

Standard on these units are the 12 volt electrical fifth wheel jacks. Before using the jacks, read and closely follow the operation instructions provided by the jack manufacturer. To lift the unit for uncoupling, drop the pad tube by removing the lock pin. Re-pin the hole that places the foot pad closest to the ground to compensate for variations in the terrain between the jacks. Push the toggle switch to the "DOWN" position and hold until the jack raises the unit to the desired height.

CAUTION

Before raising the jacks, make sure the hitch is securely latched by applying the trailer brakes and slowly pulling the tow vehicle forward. The unit should prevent the tow vehicle from moving.

To raise the jacks after coupling, push the toggle switch to the "UP" position and hold until the jacks are fully retracted. Release the toggle switch as the lock pin in the inner ram tube nears the end of the outside tube to avoid unnecessary wear on the motor clutch. Remove the lock pins and raise the pad tubes, re-pinning them in the highest possible position.

CAUTION

When the jacks reach their maximum extended or retracted length or maximum load, you will hear a clicking noise. This is the slip clutch built into the motor to prevent jack overextension or retraction. Release the toggle switch as soon as you hear the clicking. Continued operation with the clutch slipping can damage the jacks.

These jacks can be operated manually, if necessary. Insert the hand crank into the alignment tube until the end engages with the crank shaft. Turn the crank handle counter clockwise to raise the trailer. Remove and store the crank handle. To raise the jacks after coupling, rotate the crank handle clockwise. Retract as far as possible with the crank handle, then remove the lock pin and raise the pad tube and re-pin it in the highest possible position. Please refer to the jack manufacturer Operation Instructions for further assistance.

The snaps for the fifth wheel jacks are a standard feature on this model.

Electric Steps (Optional)

Installation of the electric steps is an optional feature. These are installed in place of the standard manual steps. Operation for the electrical entrance door step is as follows:

1. With the entrance door open, turn the step power switch on.
2. Close the door. The step should retract and lock in the up position.
3. Open the door. The step should extend and lock in the down position.
4. Turn the step power switch off. The step should remain in the extended position with the under step light off when the door is closed. Turning off the power with the step retracted will hold the step in a retracted position as well.

CAUTION

If the vehicle is towed with the step in the extended position, there is the possibility of causing major damage to both the step and the vehicle.

Notes

CHAPTER 10

INTERIOR FEATURES

Table of Contents

Bedspread	10 - 1
Flooring	10 - 1
Ceiling	10 - 1
Window Treatment	10 - 1

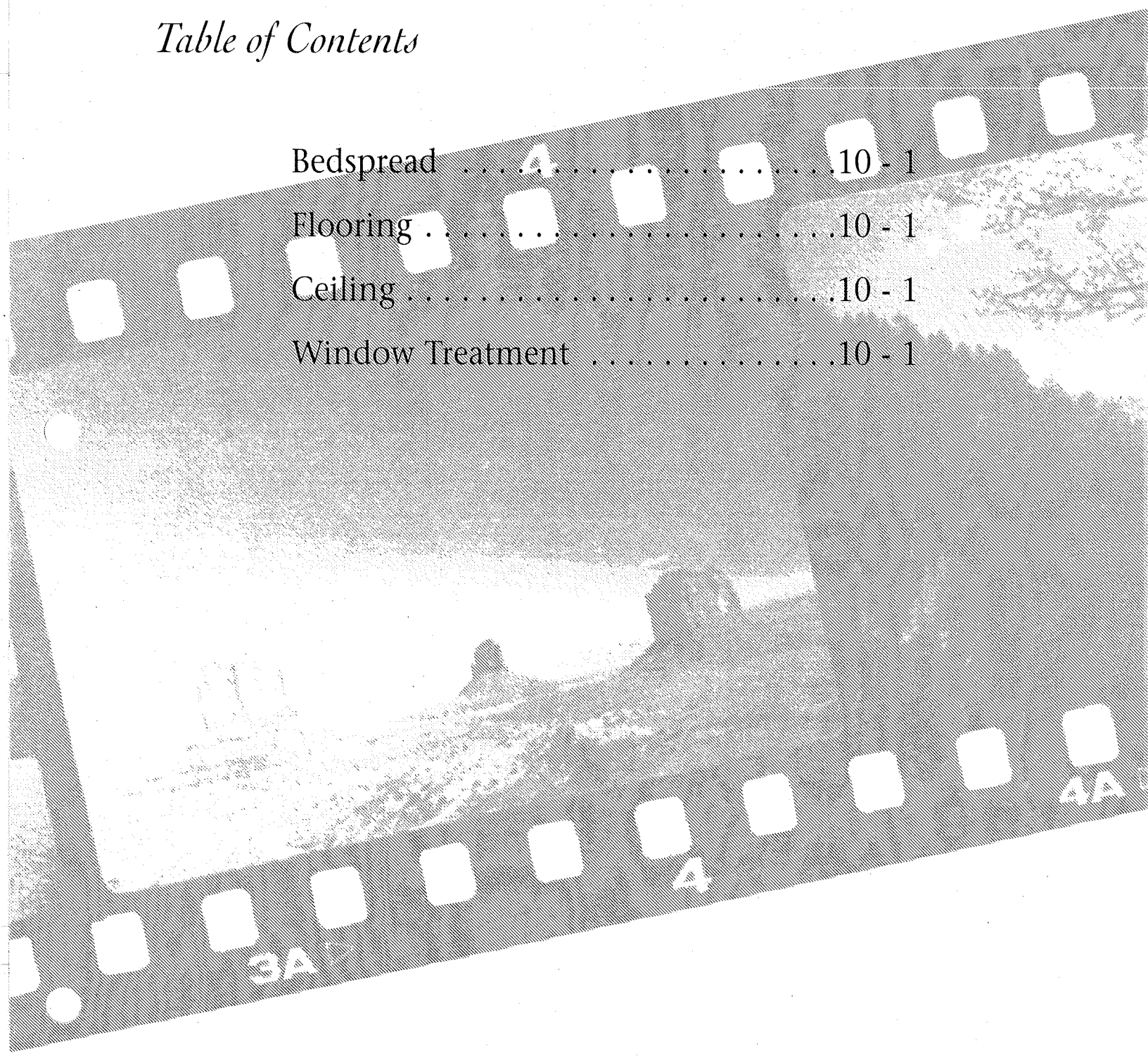

INTERIOR FEATURES

Bedsread

All units have a decor matching bedspread enclosed as part of the standard package. The recommended cleaning instructions for this spread are Dry Clean Only. The materials that make up the spread may have been treated and dry cleaning will preserve this treatment.

Flooring

The floor covering in the living room, bedroom, and the bathroom of the unit is carpet. In the Owner's Package you will find literature supplied by the carpet manufacturer. This information will be helpful in maintaining and extending the life of the carpet. Please refer to this information for the carpet care and cleaning instructions. The floor covering in the kitchen and the foyer area is the popular hardwood plank flooring. An optional floor covering in the kitchen and bath area is vinyl linoleum. An additional option in the bath is the ceramic tile flooring. To clean either of these floor treatments, use a mild soap with warm water and a soft cloth.

Ceiling

The ceiling in this unit is covered with a woven soft touch ceiling covering. The recommended cleaning instructions are to have the ceiling professionally dry cleaned.

Window Treatment

The window treatment throughout this unit, except in the kitchen, is pleated day/night soft shades with lined drapes. These shades have two sections. The first section visible when closing the shade is the "DAY" section. This material is translucent. Sun light passes easily through the material into the unit. The second visible section is the "NIGHT" section. This material is a heavier, more opaque material. Very little to no light passes through it. It is generally used in the evening or when more privacy is desired. The kitchen window is equipped with a mini-blind.

Notes

CHAPTER 11

PLUMBING & BATH FEATURES

Table of Contents

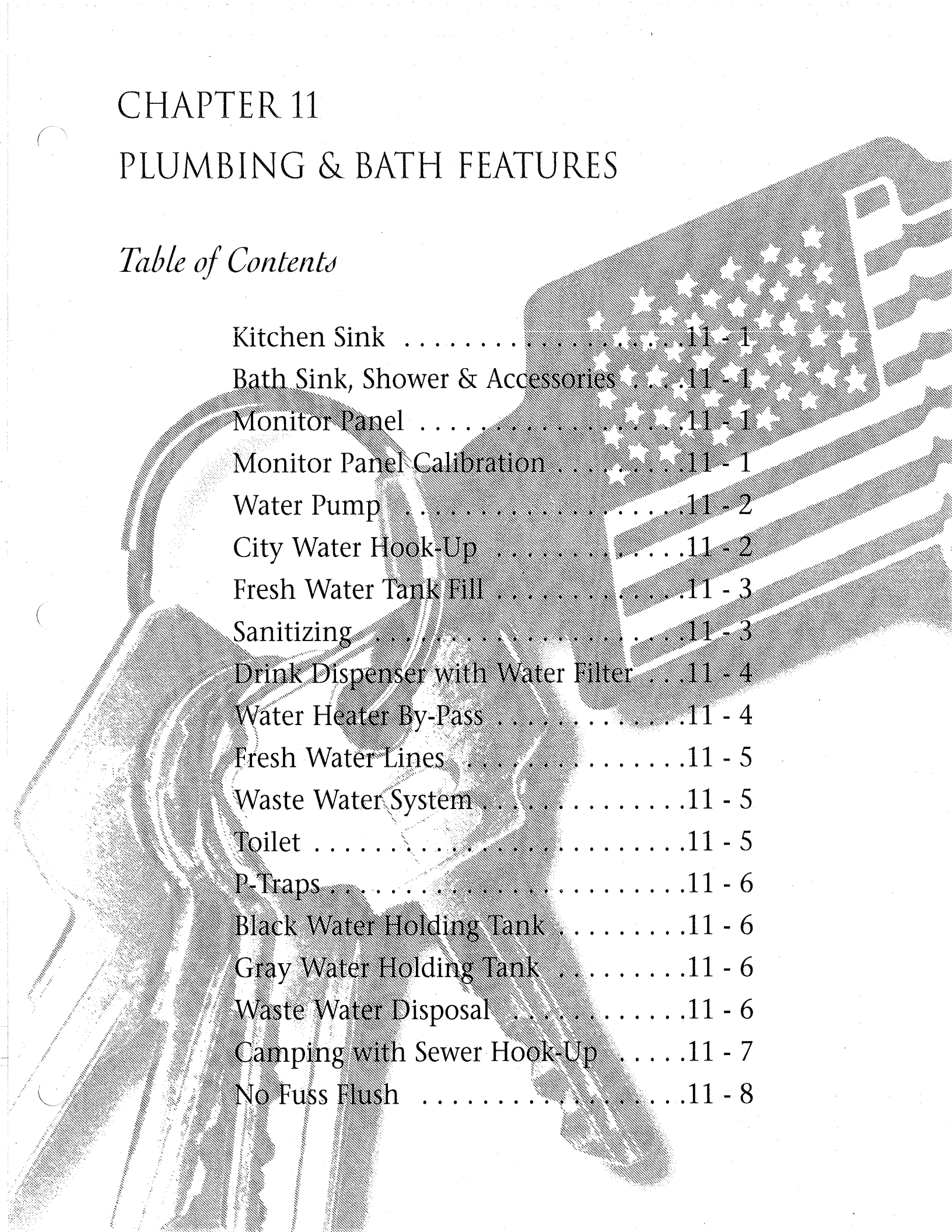

Kitchen Sink	11 - 1
Bath Sink, Shower & Accessories	11 - 1
Monitor Panel	11 - 1
Monitor Panel Calibration	11 - 1
Water Pump	11 - 2
City Water Hook-Up	11 - 2
Fresh Water Tank Fill	11 - 3
Sanitizing	11 - 3
Drink Dispenser with Water Filter	11 - 4
Water Heater By-Pass	11 - 4
Fresh Water Lines	11 - 5
Waste Water System	11 - 5
Toilet	11 - 5
P-Traps	11 - 6
Black Water Holding Tank	11 - 6
Gray Water Holding Tank	11 - 6
Waste Water Disposal	11 - 6
Camping with Sewer Hook-Up	11 - 7
No Fuss Flush	11 - 8

FRESH WATER SYSTEM

Kitchen Sink

The kitchen sink installed is a double bowl stainless steel sink. The unit has two sink covers to provide additional counter space when the sink is not in use. Stainless sinks do not rust or chip. Cleaning care consists of washing with mild detergents and a soft cloth. Avoid using "S.O.S." type cleaning pads because they may scratch the stainless steel surface. The faucet in the kitchen is an 8" chrome single handle Gourmet faucet by Moen.

Bath Sink, Shower & Accessories

The sink in the bathroom is made of Corian. In the Owner's Package furnished with this unit you will find care instructions for the Corian countertops and sink in this unit. The brass bathroom accessories include a towel bar, towel ring, tissue holder, and robe hook. The faucet in the bathroom is a brass single handle faucet by Moen. The shower installed is a fiberglass combination tub and shower enclosure. Some floorplans can have the corner shower option. The accessories accent the brass tub faucet, shower head, hose, and bracket.

Monitor Panel

The monitor panel allows you to check the approximate levels in the fresh, gray, and black water holding tanks, and the battery condition. The monitor panel is generally located in the bathroom. Simply press the button of the item to check its status. The empty indicator light will always light when the button is pressed. If the tank is full, all of the lights will be on. Lights are sequential, and indicate the level in approximately $\frac{1}{4}$ tank increments. For example: If the tank selected is approximately $\frac{1}{2}$ -full, then the indicator lights E, $\frac{1}{4}$, and $\frac{1}{2}$ will be lit. On the right hand side of the monitor panel is the water pump switch. This switch controls the power going to the water pump, turning it either on or off.

Monitor Panel Calibration

The monitor panel comes to you factory calibrated for accuracy and should not need to be adjusted. In the event that the system does not read accurately, then re-calibration may be necessary. The procedure for re-calibration is simple: First, fill the tank to be re-calibrated. Second, using the adjustment tool enclosed in the Owner's Package (or any small flat-bladed screw driver) simultaneously push the button for that tank and rotate the adjustment screw located above the button and behind the face plate counter-clockwise until some of the lights turn off in sequence. Then slowly rotate the adjustment screw clockwise until the full light is completely on. Repeat this procedure as necessary for the remaining tanks. The system is now calibrated properly.

Turn the city water supply on for a few seconds in order to clear the line. Once the hose has been flushed, turn the supply off. Connect the other end of the hose to the city water connections. Turn on the water supply and open all of the faucets to clear the air from the lines in the unit. Once air pockets have been purged from the water lines and water flows freely, close all of the faucets. The city water supply is under pressure, therefore the water pump is not necessary when connected to city water. Once the city water fill valve is opened, water is supplied to the fresh water system including the hot water heater, faucets, and stool. To disconnect from the city water supply, close the valve and remove the hose from the city water supply. Disconnect the hose from the city water connection and store the hose in the water compartment.

Fresh Water Tank Fill

The fresh water tank is filled from the city water hook-up. The valve located in the service compartment near the water hook-up determines whether the city water is going through the water system or into the fresh water tank. Since there is not an automatic shut-off for the fresh water tank fill, check the level from the monitor panel while filling the unit. The excess water will be vented from an overflow vent pipe onto the ground when the tank capacity has been reached. This pipe is installed in the fresh water tank to prevent rupture from over filling. All of the water should be drained from the fresh water system when the unit is not in use for more than one week. Whenever possible, drain the fresh water tank before traveling. Water in the tank will reduce the carrying capacity of the unit.

SANITIZING

To assure complete disinfecting of your fresh water system, it is recommended that the following procedure be followed on a new system, on one that has not been used for a length of time, or one that may have become contaminated. This procedure is also recommended before long periods of storage, such as over the winter months:

1. Drain the fresh water tank by opening the drain valves. There is one valve per water tank. All of the faucets should be in the closed or off position.
2. Prepare a chlorine solution using one gallon of water and $\frac{1}{4}$ cup of chlorine bleach (5% sodium hypo-chlorite solution). Prepare enough of the chlorine solution to administer one gallon of solution for every 15 gallons of tank capacity. For sanitizing this unit, prepare $4\frac{1}{2}$ gallons of the chlorine solution. This mixture puts a 50 PPM (parts per million) residual chlorine concentration in the water system that will act as a quick kill dosage for harmful bacteria, viruses and slime forming organisms. Concentrations higher than 50 PPM may damage the water lines and/or tank.
3. Once the fresh water tank is empty, close the drain valves on the water tank.
4. Pump the chlorine solution into the tank. This is done by placing the winterizing hose into the chlorine solution. Close the valve from the fresh water tank to the pump and open the valve from the solution to the pump. Turn the tank fill valve from city water to tank fill. Turn on the water pump until all of the solution is pumped into the fresh water tank.

Fresh Water Lines

Vibration and flexing during traveling can cause pipes and fittings to work loose. Check all of the plumbing connections for leaks on a yearly basis. If the water pump runs when all faucets are turned off, check for a leak. Be sure the drain valves are closed. Connections at the kitchen and bathroom faucets normally seal with hand tightening and a half turn with a wrench. If a fitting leak persists, disconnect it completely and check for mineral deposits or foreign material on the sealing surfaces. Clean the surfaces thoroughly and reinstall the fitting. Take the coach to an authorized service center for repairs if the system continues to leak. Follow the winterizing instructions given in Chapter 14 to reduce the risk of leaks caused by cracks from freezing pipes. Freezing damage can be extensive and expensive.

WASTE WATER SYSTEM

General Information

The waste drainage system was designed to provide adequate and safe storage and/or disposal of waste materials. All of the material used in the making of this system are tested by a nationally recognized testing laboratory. The drainage system uses ABS plastic piping and fittings connected to the sinks, toilet, and holding tanks. This provides for their drainage to an outside termination. The unit should be reasonably level for best operation of the system. There are two separate waste systems. The gray water system is for waste water from the sinks and shower. The black water system is generally for sewage waste from the stool. Each tank has its own control valve and both tanks drain through the sewer drain hose.

Toilet

The stool operates with water from either the fresh water tank with the water pump on or the city water supply. Before using the stool, add water to the bottom of the tank. Refer to the 'BLACK WATER TANK' instructions in this chapter. The stool flushes wastes directly into the black water holding tank. The stool uses high velocity water injection to produce a swirl effect in the bowl. The greatest problem that causes stool solids to build up in the holding tank is lack of liquids. When using your stool, it is wise to fill the stool 3/4 full of water. This will help to wash the solids away from directly below the stool and to ensure complete dumping of the holding tank. Depending upon the model installed, water can be added to the stool bowl by lifting up on the lever. To flush the stool, push down on the lever until water swirls.

The stool requires little maintenance. Use an approved non-abrasive cleaner to clean the bowl. Spraying the bowl sealing blade with a silicone spray will retain the original smooth operating condition.

Check the complete instruction and trouble shooting guide in the stool manufacturer's Owner's Manual provided in the Owner's Package.

Whenever possible, drain the holding tanks prior to traveling. The carrying capacity of your unit will be reduced if water is left in the black or gray tanks.

The holding tanks should only be drained when they are at least $\frac{3}{4}$ full. Doing this will provide sufficient water to allow the complete flushing of waste materials in the drain lines and hose. If the tanks are not $\frac{3}{4}$ full, add enough water to allow for sufficient flushing.

To empty the waste water tanks, connect the adapter to the drain hose. Use the adapter supplied with your unit. If the adapter is lost or broken, one can be purchased from most RV supply stores. Once you have placed the adapter on the drain hose, it can remain there for the life of the hose. Unscrew the cap off the drain. Connect the hose with the adapter in place to the drain fitting. Open the gate valve all the way by pulling on the T-handle. The tank will start to drain as soon as the T-handle is pulled. After you have drained the black water tank, immediately drain the gray water tank. Doing this helps to flush the black water from the sewage hose.

When both of the tanks are empty, flush them with a fresh water rinse before you close the valves. The gray tanks are easily flushed by pouring a couple of gallons of water into a sink drain. Prime the system with an odor control chemical following the directions above for preparing the system for use. The drain outlet is engineered for quick release of the drain hose adapter. Always close the gate valves and secure the end cap to prevent leakage while in transit. After draining, add enough water to the black water tank to cover the bottom.

When using dump stations for draining the holding tanks, keep other travelers in mind. Practice good housekeeping. Leave the dump stations in good order. Above all, do not pollute.

Camping with Sewer Hook-Up

When camping at parks with sewer hook-up, it is important to keep the black water holding tank gate valve closed at all times, except when dumping. The gray tank can be kept open while hooked to a sewer connection but again, the black water tank must be kept closed. This is done so that an ample supply of liquid remains in the tank to provide a smooth flow through the gate and drain valve when dumping. Sufficient liquid in the tank causes a swirling action that should take any accumulated solid wastes with it. Accumulation of solid wastes in the black water tank can be avoided by keeping the gate valve closed when connected to the sewer hook-up. If the valve is left open, solid wastes may accumulate in the tank. This may eventually result in costly repairs. The gray tank valve needs to be in the open position when operating the optional washing machine.

Notes

CHAPTER 12

CONSTRUCTION FEATURES

Table of Contents

Construction Features	12 - 1
---------------------------------	--------

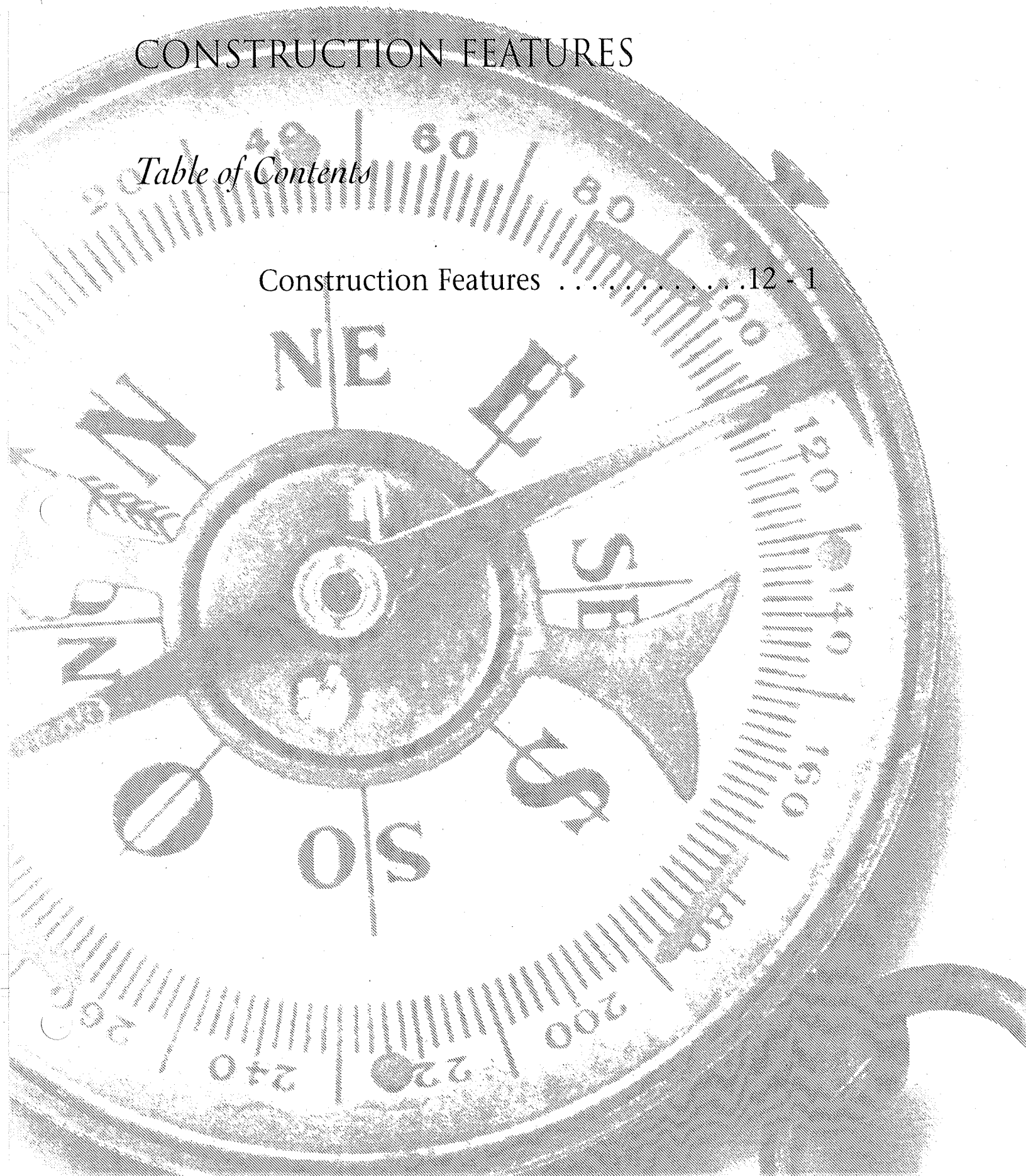

CONSTRUCTION FEATURES

The floor decking is constructed of durable $\frac{1}{2}$ " structure wood. The fiberglass insulation in the floor is rated at R19. The underbelly on these models is enclosed with aluminum laminated $\frac{5}{8}$ " foam board. The rear bumper pulls out with a slide out tray for the spare tire.

On this model, each sidewall is constructed for strength and is heavily insulated for comfort. Welded, for added strength, the widebody extruded aluminum sidewalls and roof are built with 16" on center framing, providing the strongest and most durable construction. The inside consists of $\frac{5}{8}$ " beaded foam that is laminated to kraft paper and covered by the interior paneling. A blanket of rolled insulation is added to the sidewalls, roof, and slide out to provide a greater efficiency and consistency of climate control. The sidewall insulation is rated R7, while the roof is rated R19. In addition, under the exterior roof is a layer of $\frac{1}{4}$ " foam board insulation. This will assist the furnace in the winter by keeping the warm in and the cold out. In the summer months, it will assist the air conditioning by keeping the cool air in and the hot air out.

Below are examples of the framing and insulation that your unit is constructed with.

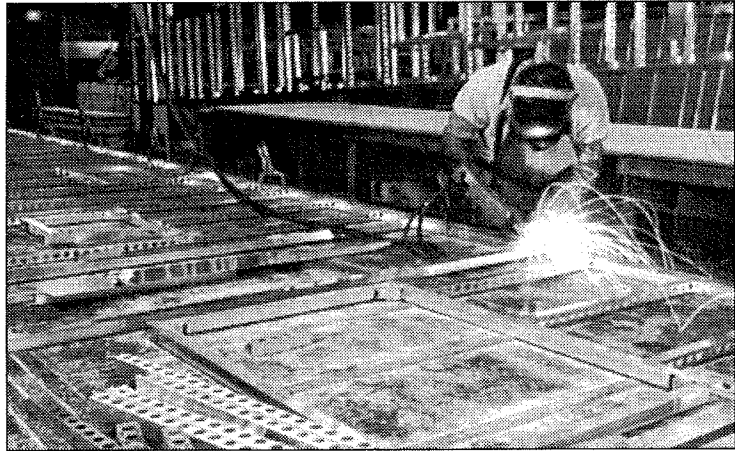
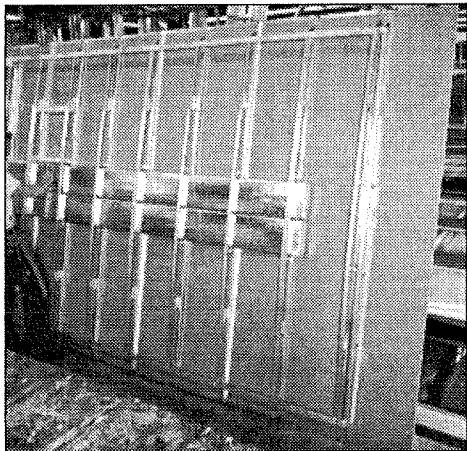

CHAPTER 13

WINDOWS, AWNINGS, VENTS & DOORS

Table of Contents

Windows	4	13 - 1
Awnings	13 - 2
Window Awnings	13 - 3
Vents	13 - 4
Doors	13 - 5

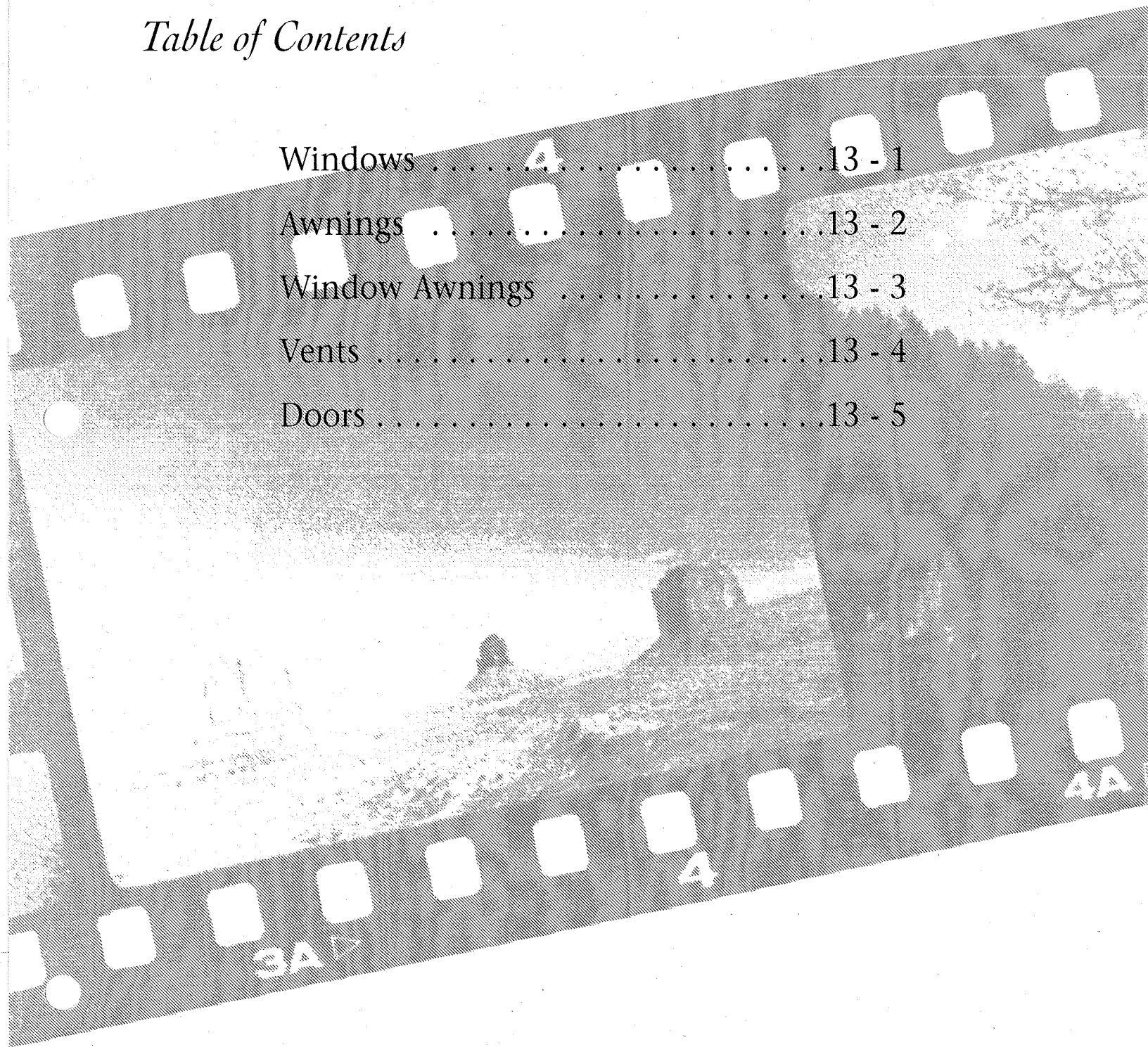

Window Awning (Optional)

Also optional on this unit are the matching window awnings for the bedroom and the slide out room windows. To operate these, use the following instructions:

EXTENDING

1. Grasp the loop on the pull strap and pull down to extend the awning. Then hook the loop onto the window strap hanger.

RETRACTING

1. Remove loop on the pull strap from the window strap hanger.

CAUTION

Do not release the strap as the window awning is under tension and may snap back against the vehicle.

2. Slowly allow the awning to roll back to the closed position by feeding the pull strap upwards and diagonally. This prevents the strap from building up and creating a bulge in the fabric.
3. The window awning is now ready for travel with no further locking required.

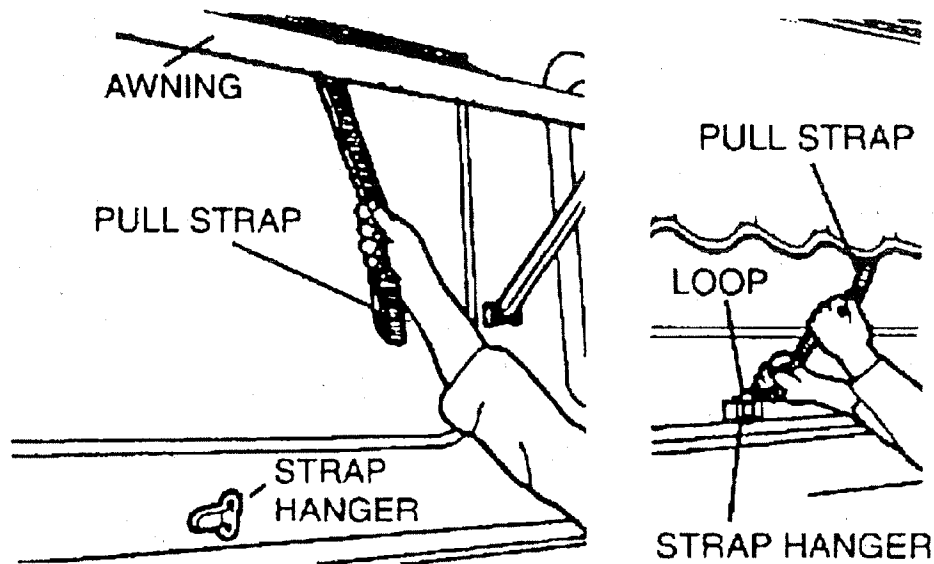

CHAPTER 14

ROUTINE MAINTENANCE

Table of Contents

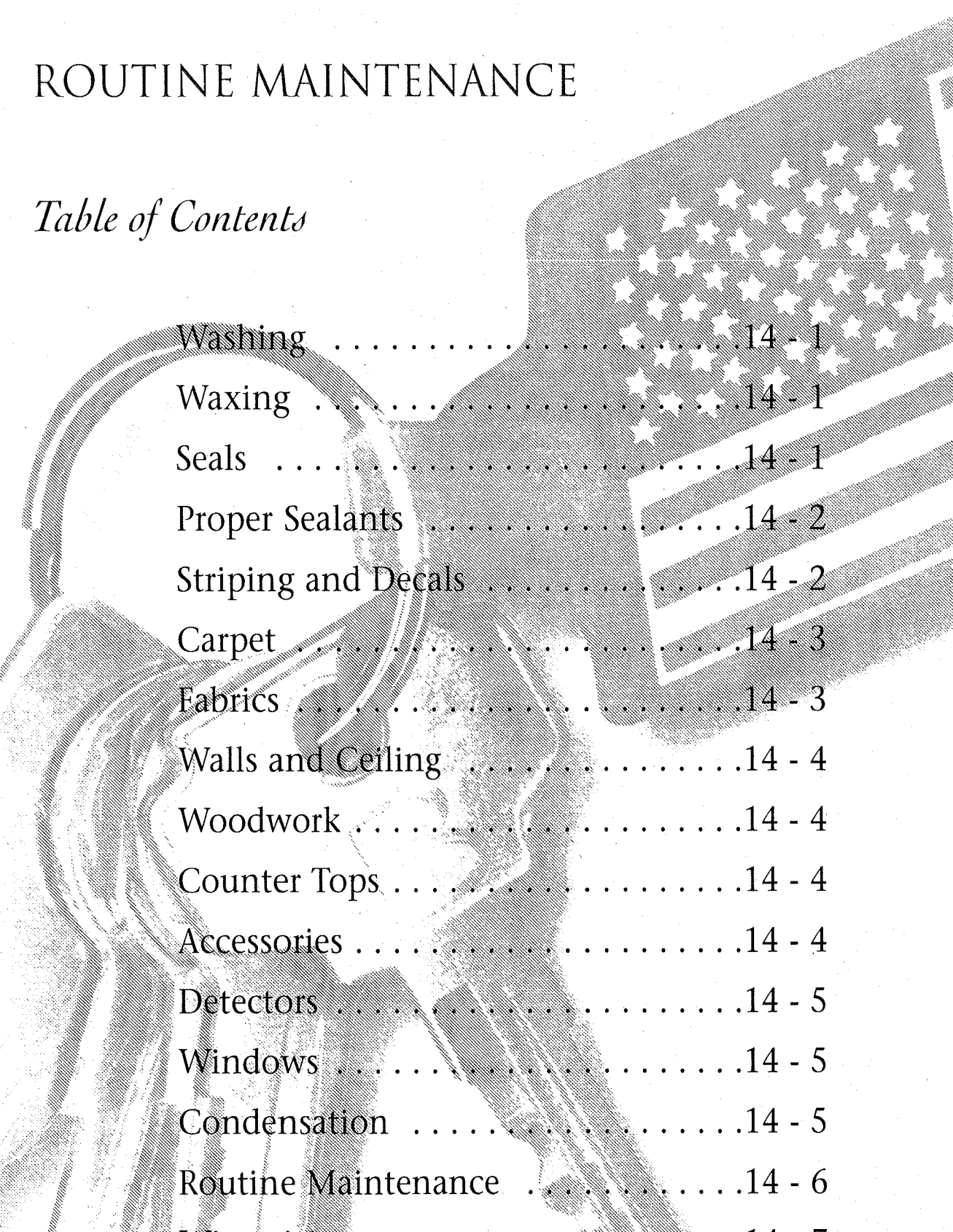

Washing	14 - 1
Waxing	14 - 1
Seals	14 - 1
Proper Sealants	14 - 2
Striping and Decals	14 - 2
Carpet	14 - 3
Fabrics	14 - 3
Walls and Ceiling	14 - 4
Woodwork	14 - 4
Counter Tops	14 - 4
Accessories	14 - 4
Detectors	14 - 5
Windows	14 - 5
Condensation	14 - 5
Routine Maintenance	14 - 6
Winterizing	14 - 7

EXTERIOR CARE

Washing

The exterior of your new camping vehicle is made of pre-finished aluminum and fiberglass. Frequent washings and thorough cleanings are recommended to prevent damage to the vehicle finish after exposure due to damaging salts, calcium chloride, road tar, tree sap, insects, and other foreign material. Never wash the vehicle in direct sunlight, while the vehicle is hot, or with hot water. Build up of mud and dirt under the body can cause damaging rust on steel parts and can add needless weight to the vehicle. Corrosive materials, such as those used for ice and snow removal and dust control, also accumulate on the underside of the vehicle. These materials should be removed by flushing the underbelly regularly with water, especially areas where mud and other foreign materials collect. The chance of corrosion can be minimized by frequent washings of the vehicle. When washing the vehicle, make certain that the undercarriage and the wheel wells are cleaned, as well as the exterior of the coach. Do not use strong soaps or detergents for washing the vehicle. Always use a mild soap in warm water, a commercially prepared product for automotive finishes, or your local car wash. Be careful when using a pressure-type washer to avoid loosening any exterior decals or sealants, etc. After washing, carefully inspect the caulking around window frames and vents and any other joints that may have separated. Recaulking, if necessary, is relatively simple.

IMPORTANT

Never use a strong solvent, such as lacquer thinner, or harsh abrasives, on any of the exterior painted surfaces.

Waxing

The exterior finish will require a routine waxing. When water will not bead and roll off a freshly washed vehicle, a new coat of wax is needed. Wax not only improves the appearance of the vehicle, but it also protects the finish against oxidation and corrosive materials. The recommended type of wax is one that is compatible with painted and gel-coated fiberglass finishes. Cleaning with a polishing compound will improve a dull or discolored finish.

IMPORTANT

When using a polishing compound that does not contain a wax preservative, reapplying a coat of hard wax after polishing is recommended.

Seals

The seals around doors, windows, vents, and external seams should also be checked at least twice a year. Check the roof seams once a year for cracking or peeling. If deterioration is noted, reseal the seams or seals with an approved sealant to prevent leaks. Your dealer can

IMPORTANT

Do not use solvents such as acetone, MEK, toluene, etc. on the decals. Any solvent including alcohol may soften or smear colors. Do not use lacquer thinner or paint on decals. Do not overcoat the decals with clear paint. Do not allow gasoline or other fuels to drip or stay on the decals for any length of time. If this occurs, immediately flush the area with water.

INTERIOR CARE

WARNING

Urea-formaldehyde is used in the productions of particle board, hardwood plywood, and most paneling. Urea-formaldehyde resin may release formaldehyde vapors into the air, which may cause headaches, and in some people, eye, nose, and throat irritation. Formaldehyde may intensify some allergies or upper respiratory problems like asthma. Proper ventilation should reduce the risk of such problems.

Carpet

A weekly routine of vacuuming the carpet and fabrics, throughout the vehicle is recommended. Doing this will prevent an accumulation of dirt that can detract from the materials appearance and shorten its life.

Included in the Owner's Information Package is the carpet manufacturer's Carpet Care Guide. The Carpet Care Guide lists detailed information on cleaning soiled areas and removing stains from the fine carpet installed in the unit.

Fabrics

The fabrics used in this unit for the bedspread, draperies, headboard, and valances may contain fire retardant additives that can be damaged by use of improper cleaning products. Water-based products are not recommended for cleaning the fabrics in your new unit. Most water-based household cleaning products are not formulated for use on these fabrics and may cause excessive shrinkage or fading. Always test any cleaning product on a hidden area of fabric before using on visible areas. For best results, the fabrics in this unit should be cleaned by a professional carpet and upholstery cleaner.

Spills, spots, or stains should be treated as soon as possible to avoid permanent damage. If a spill occurs, blot the fluid with a dry towel. Do not rub the spill. Rubbing may cause the liquid to 'set' in the fabric. When attempting to clean a spot or stain, always start from the outside and work inward to avoid spreading it further. Some stains or soils are extremely difficult or impossible to be removed completely. These should receive immediate professional attention.

Detectors

The CO and LP detectors are self-contained and DO NOT require any maintenance other than normal cleaning and dusting. When cleaning the exterior of the case use a damp cloth or paper towel. Do not spray cleaners or wax directly into the case as it may cause false alarms.

Windows

The glass in the windows may develop water spots, especially if water containing salts or other matter is not properly removed. The spotting effect is magnified when the glass has a reflective finish. Using a squeegee immediately after washing will help reduce water spotting.

Condensation

The following information is to make the retail owner of this unit aware of the potential problem with condensation in a recreational vehicle. Damage may occur to your unit if excessive condensation exists.

Accumulation of condensation on surfaces within your unit occurs when warm moist air contacts a cool surface. It is most evident on the inside of windows not protected by storm windows during the winter season. This problem can be controlled by the occupants of the recreational vehicle by:

1. Opening a window or roof vent slightly to allow the moisture to escape from the unit.
 2. Using a small dehumidifier to remove moisture from the air.
- Condensation levels are highest during times when a person is cooking or taking a shower in the unit, but these are not the only times condensation is present.
 - Condensation may cause many problems with your new unit. It can migrate through ceiling panels and saturate the fiberglass insulation in your ceiling cavity. This condition often causes the occupants to believe the recreational vehicle has a roof leak when it drips back into the interior of the coach. Walls and ceiling panels may also become wet when the moisture accumulates on these surfaces.
 - Since surface condensation within the coach cannot be controlled by the manufacturer, damage caused by condensation is not covered by your warranty agreement.
 - Although condensation can be a serious problem, it can be easily controlled by the occupants of a recreational vehicle. By following the above guidelines your new coach can be used in cool climates without condensation problems.
 - Newmar Corporation does not recommend the use of un-vented catalytic heaters. If catalytic heaters are used the customer must use a dehumidifier in conjunction with the catalytic heater. The use of unvented catalytic heaters may cause carbon monoxide poisoning.

Winterizing

To store your unit for the winter months, it is necessary to winterize the water system to help prevent freezing. To do this, follow these instructions:

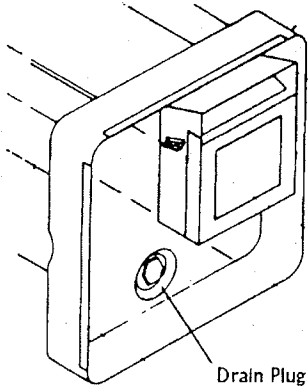
1. The water heater must remain off during this process. Shut off the water pump and make sure the water supply valves are closed. Disconnect the city water fill.
 2. To drain the fresh water tank, open the drain valves.
 3. Open the low point drain valves. There is one drain valve for each water line, one cold and one hot. This is done to drain all of the water out of the system.
 4. After the water heater has cooled off, remove the drain plug to drain the water from the water heater. In the exterior compartment beside the water heater there are two water heater shut off valves and a by-pass valve. The shut off valves must be closed and the by-pass valve must be open, prior to winterizing to prevent the antifreeze solution from entering the water heater.
- 
- The diagram shows a perspective view of a rectangular exterior compartment. Inside, there is a water heater tank. A small circular drain plug is located on the front panel of the compartment, below the tank. A line points from the text 'Drain Plug' to this plug.
5. Close the low point drains to prevent the antifreeze from draining through the lines onto the ground.
 6. Close the water supply valve that flows from the pump to the tank. Remove the water filter, if installed. (See Chapter 11 for more information.)
 7. Use only non-toxic antifreeze that has been approved for use in drinking/potable water systems. Place the in-take hose into the antifreeze supply. Open the antifreeze valve to allow the solution to flow freely. Once the water pump is turned on, proceed to the kitchen faucet, bath faucet, inside and outside shower, turning on the hot and cold, and flushing the stool until the antifreeze solution flows freely. If the unit is equipped with a washer, be certain to purge the air from it also. This forces the antifreeze through all of the water lines and faucets. It also allows the antifreeze solution to enter the drain lines and prevent the P-traps from freezing. Check the antifreeze solution from time to time to make sure there is an adequate supply.
 8. Close the antifreeze valve when the winterizing process is complete. Store the in-take hose and turn the water pump off.
 9. Open the water supply valve that flows from the pump to the tank to help prevent freezing on that water line.
 10. To de-winterize your unit, open both of the low point drains to allow the antifreeze solution to drain from the water system. Next, close the low point drains and connect your unit to city water. Put water in the fresh water tank and pump at least one gallon through the water pump in order to remove the antifreeze from the water pump. Keep the water heater supply valve closed and the water heater bypass valves open. The supply valve for the fresh water tank from the pump must remain closed. As in winterizing, open the kitchen faucet, bath faucet, inside and outside shower, turning on

Winterizing

To store your unit for the winter months, it is necessary to winterize the water system to help prevent freezing. To do this, follow these instructions:

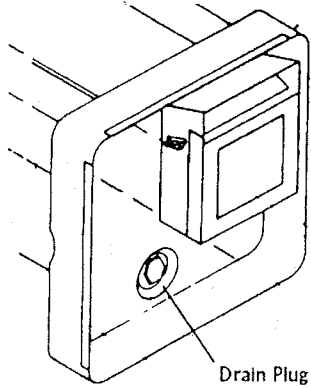
1. The water heater must remain off during this process. Shut off the water pump and make sure the water supply valves are closed. Disconnect the city water fill.
 2. To drain the fresh water tank, open the drain valves.
 3. Open the low point drain valves. There is one drain valve for each water line, one cold and one hot. This is done to drain all of the water out of the system.
 4. After the water heater has cooled off, remove the drain plug to drain the water from the water heater. In the exterior compartment beside the water heater there are two water heater shut off valves and a by-pass valve. The shut off valves must be closed and the by-pass valve must be open, prior to winterizing to prevent the antifreeze solution from entering the water heater.
- 
- The diagram shows a cross-section of the exterior compartment of a water heater. A rectangular panel is partially open, revealing internal components. A small circular drain plug is located on the lower left side of the compartment. A label 'Drain Plug' with a leader line points to this plug. The interior shows a tank and various pipes and valves.
5. Close the low point drains to prevent the antifreeze from draining through the lines onto the ground.
 6. Close the water supply valve that flows from the pump to the tank. Remove the water filter, if installed. (See Chapter 11 for more information.)
 7. Use only non-toxic antifreeze that has been approved for use in drinking/potable water systems. Place the in-take hose into the antifreeze supply. Open the antifreeze valve to allow the solution to flow freely. Once the water pump is turned on, proceed to the kitchen faucet, bath faucet, inside and outside shower, turning on the hot and cold, and flushing the stool until the antifreeze solution flows freely. If the unit is equipped with a washer, be certain to purge the air from it also. This forces the antifreeze through all of the water lines and faucets. It also allows the antifreeze solution to enter the drain lines and prevent the P-traps from freezing. Check the antifreeze solution from time to time to make sure there is an adequate supply.
 8. Close the antifreeze valve when the winterizing process is complete. Store the in-take hose and turn the water pump off.
 9. Open the water supply valve that flows from the pump to the tank to help prevent freezing on that water line.
 10. To de-winterize your unit, open both of the low point drains to allow the antifreeze solution to drain from the water system. Next, close the low point drains and connect your unit to city water. Put water in the fresh water tank and pump at least one gallon through the water pump in order to remove the antifreeze from the water pump. Keep the water heater supply valve closed and the water heater bypass valves open. The supply valve for the fresh water tank from the pump must remain closed. As in winterizing, open the kitchen faucet, bath faucet, inside and outside shower, turning on

CHAPTER 15

CHARTS & DIAGRAMS

Table of Contents

Model Numbers	15-1
Maintenance Record	15-3
Fuel & Mileage Log	15-5
12 Volt Distribution Panel	15-7
30 Amp Distribution Panel	15-9
50 Amp Distribution Panel	15-11
Wiring Color Scheme	15-13
Typical 110 Volt Wiring Diagram	15-17
Typical 12 Volt Wiring Diagram	15-19
Typical Fresh Water Diagram	15-21
Typical Drain Line Diagram	15-23
Slide Out Mechanism	15-25
Brief Parts Listing	15-27

**IMPORTANT INFORMATION
FOR YOUR
NEWMAR TRAILER**

Coach: Year _____ Model _____ Serial _____

Appliance	Brand	Model	Serial
Refrigerator	_____	_____	_____
Water Heater	_____	_____	_____
Range	_____	_____	_____
Converter	_____	_____	_____
Washer	_____	_____	_____
Dryer	_____	_____	_____
Microwave	_____	_____	_____
Icemaker	_____	_____	_____
Television, front	_____	_____	_____
Television, rear	_____	_____	_____
Radio	_____	_____	_____
CD Player	_____	_____	_____
Generator	_____	_____	_____
Air Conditioner, front	_____	_____	_____
Air Conditioner, rear	_____	_____	_____
Blender	_____	_____	_____
Video Cassette Recorder (VCR)	_____	_____	_____
Furnace, front	_____	_____	_____
Furnace, rear	_____	_____	_____
Dishwasher	_____	_____	_____

HOT FEED LINES FROM BATTERIES AND
CONVERTER, WITH OVERCURRENT PROTECTION

GROUND TO CHASSIS, CONVERTER
AND BATTERIES MINIMUM SIZE #8

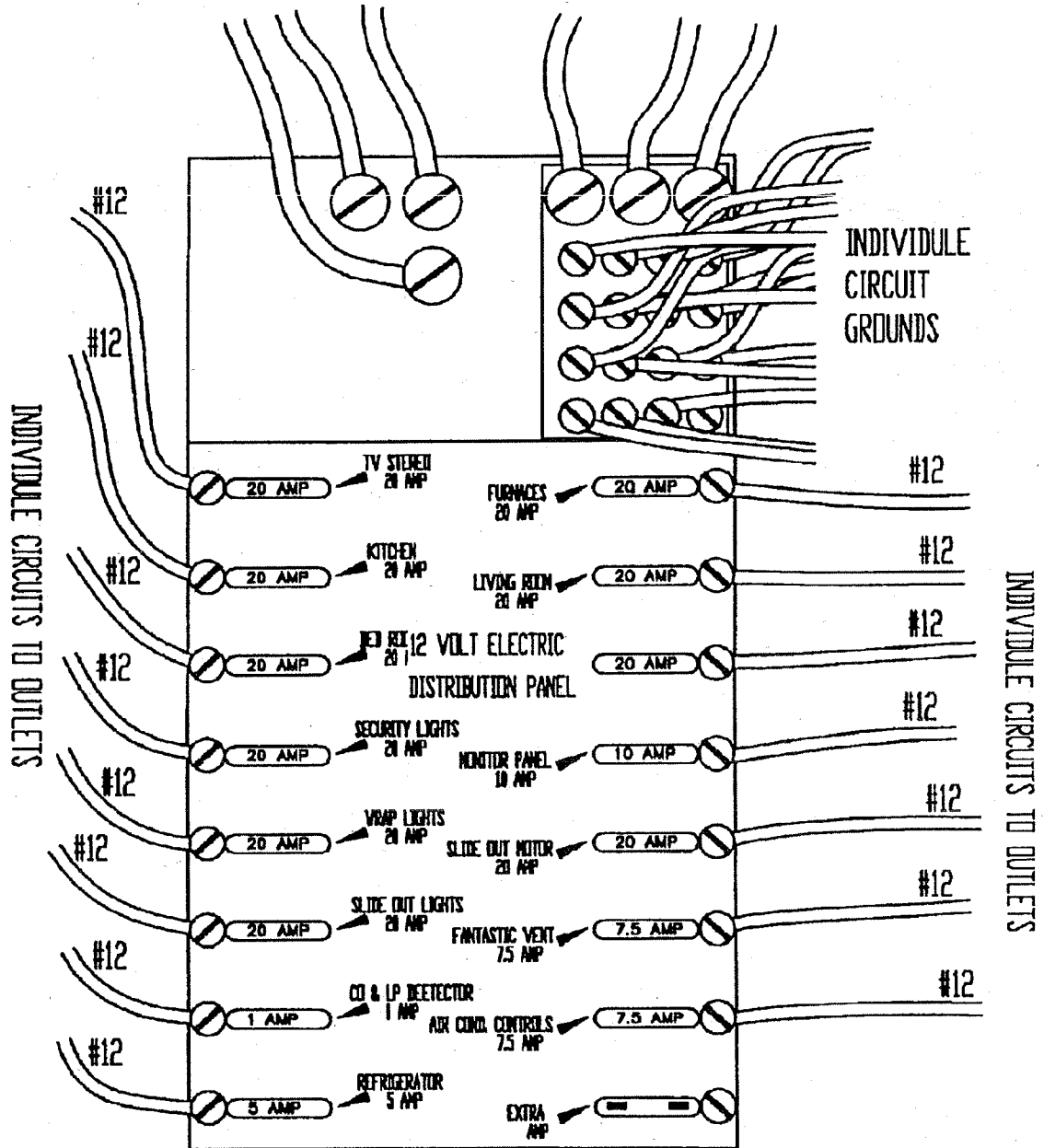

WIRE OVER CURRENT PROTECTION IS PER THIS CHART

WIRE SIZE	AMPACITY	WIRE SIZE	AMPACITY
# 6	55	# 8	40
#10	30	#12	20
#14	15	#16	8
#18	6		

12 VOLT ELECTRIC
DISTRIBUTION PANEL

load protection

30 AMP MAIN	
AIR CONDITIONER	# 1
	20 AMP
MICROWAVE	# 2
	15 AMP
CONVERTER & 8 RECEPES	# 3
	15 AMP
REFRIGERATOR & 8 RECEPES	# 4
	15 AMP
WATER HEATER	# 5
	15 AMP

30 AMP 110 SERVICE

30 Amp lead in cord & wire = 10/2 w/ground
 20 Amp circuit wire = 12/2 w/ground
 15 Amp circuit wire = 14/2 w/ground

Maximum of 10 outlets (lights and receipts) on any 15 amp circuit with no other appliance on that line. Circuits 3 and 4 may have receipts as noted at left. NOTE: A duplex receipt is counted as 1 receipt.

Not all units will get all of these items

		50 AMP MAIN			
load	protection			protection	load
1st	# 1			# 13	MAY HAVE 10 RECEPIS
AIR COND.	20 AMP			15 AMP	
MICROWAVE	# 2			# 14	MAY HAVE 10 RECEPIS
	15 AMP			15 AMP	
CONVERTER & 5 RECEPIS	# 3			# 8	MAY HAVE 10 RECEPIS
	15 AMP			15 AMP	
REFRIGERATOR FOOD CENTER & 5 RECEPIS	# 4			# 16	DISHWASHER & 2 RECEPIS
	15 AMP			15 AMP	
WATER HEATER	# 5				
	15 AMP				
DRYER	# 6				
	15 AMP				
WASHER	# 8				
	15 AMP				
2nd	# 8				
AIR COND.	20 AMP				

This is a 50 Amp 220 service

50 Amp lead in cord to box = 6/3 w/ground
 20 Amp circuit wire = 12/2 w/ground
 15 Amp circuit wire = 14/2 w/ground

Maximum of 10 outlets (lights and receipts) on any 15 amp circuit with no other appliance on that line. Circuits 3, 4, and 16 may have receipts as noted at left. NOTE: A duplex receipt is counted as 1 receipt.

This is a fully loaded system for which there has been a calculation done. Not all units will get all of these items.

Wiring Color Scheme

8 gauge

Grounds	White
Battery	Red
Converter	Black
Solar Prep	Green

10 gauge

Grounds	White
Living Room Entry Lights (hot feed)	Red
Bedroom Lights (hot feed)	Orange
Kitchen Lights (hot feed)	Green
Bathroom Lights (hot feed)	Brown
Power Rear Awning & Freezer	Purple w/Yellow
Power Step (hot feed)	Green w/Black
Power Jacks	Yellow
Electric Brakes (tri-axle)	Blue
100 Watt Inverter	Red w/White

16 gauge

Larson Monitor Panel Tank Harness	Fresh Water Tank	White* Gray w/Black (replaces Red tank lead) * Black w/Yellow (replaces Blue tank lead) *
	Gray Water Tank	White* Green w/White (replaces Red tank lead) * Blue w/Black (replaces Blue tank lead) *
	Black Water Tank	White* Red w/White (replaces Red tank lead) * Blue w/White (replaces Blue tank lead) *

* - multiple applications for this color

16 gauge

Grounds	White
Back-up Lights	Yellow
Ignition to Power Step	Pink
Clearance & Running Lights	Green
Right Turn Lights	Brown
Left Turn Lights	Red
Ignition to Slide Out Motor	Pink w/Green
Class A Blower Fan (in holding tank area)	Orange
Slide Out Switch	Purple
Courtesy Lights (hot to switch)	Grey
Courtesy Lights (switched)	Grey w/White
Detectors, CO & LP	Red w/Black
Rear Center Brake Light	Blue
LP Fuel Gauge	Red w/Yellow
Air Conditioner Controls	Pink w/Black
Monoplex Water Pump Switch	Yellow w/Black
Refrigerator Controls	Purple w/White
Vent Thermostats	Black
	Red w/White*
Water Heater DSI Switch Harness	Green w/White*
	Blue w/White*
	Red w/White*
	Green w/White*
Gas Generator	Blue w/White*
Diesel Generator	Grey w/Black*
Start/Stop Switch	Black w/Yellow*
Start/Stop Switch	White*
Harness	

* - multiple applications for this color

TYPICAL 110 VOLT WIRING DIAGRAM – FIFTH WHEEL

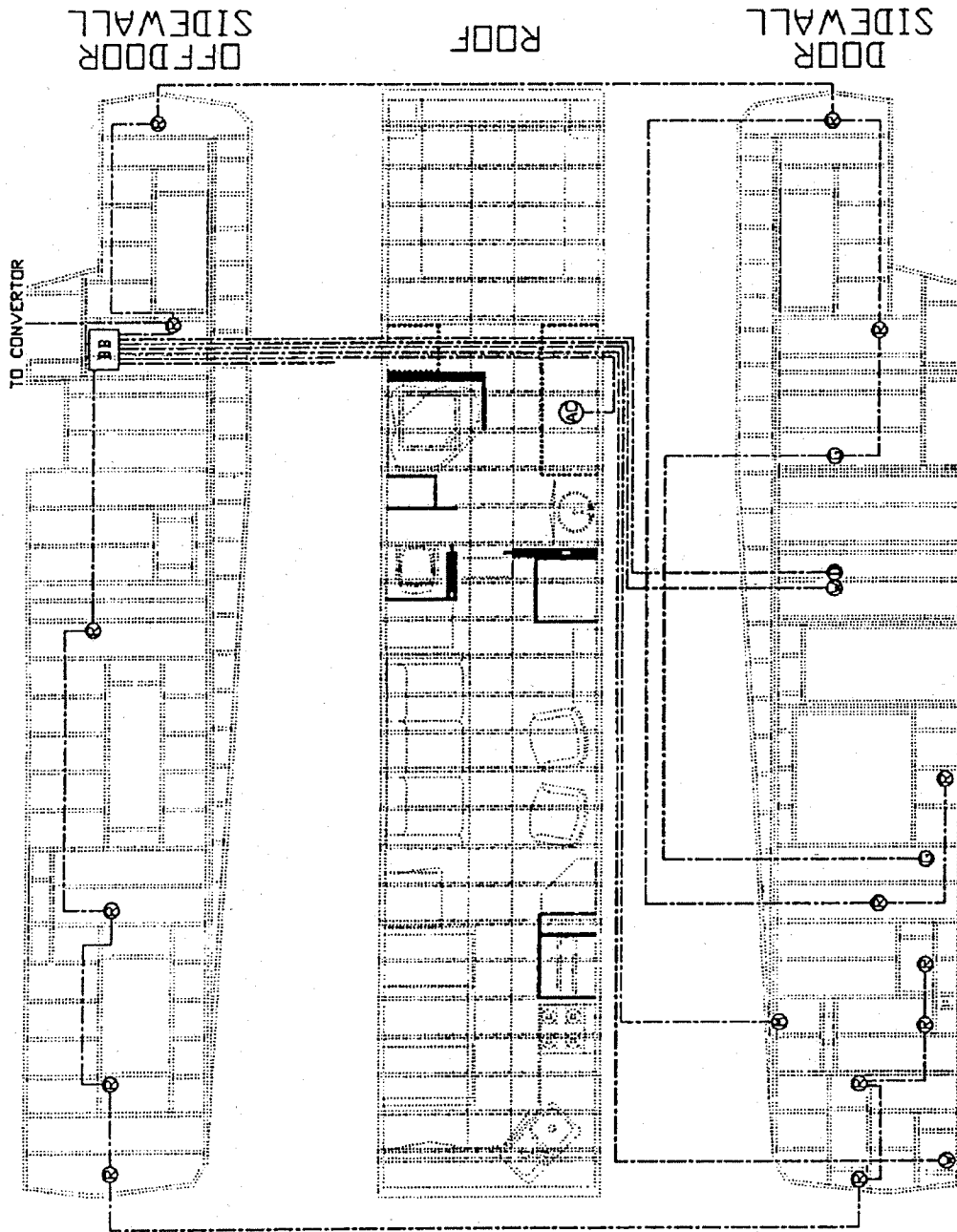

- 110 VOLT LINE
- R - RECEPT
 - G - GFI BREAKER & RECEPT
 - W - WATER HEATER
 - M - MICROWAVE
 - BB - BREAKER BOX
 - WD - WASHER & DRYER
 - AC - AIR COND CONTROL BOX

NOTE:

ALL WIRES SHOWN DO NOT NECESSARILY RUN THROUGH A SPECIFIC STUD. THIS PRINT SHOWS GENERAL LOCATIONS OF WIRES ONLY.

TYPICAL 12 VOLT WIRING DIAGRAM - FIFTH WHEEL

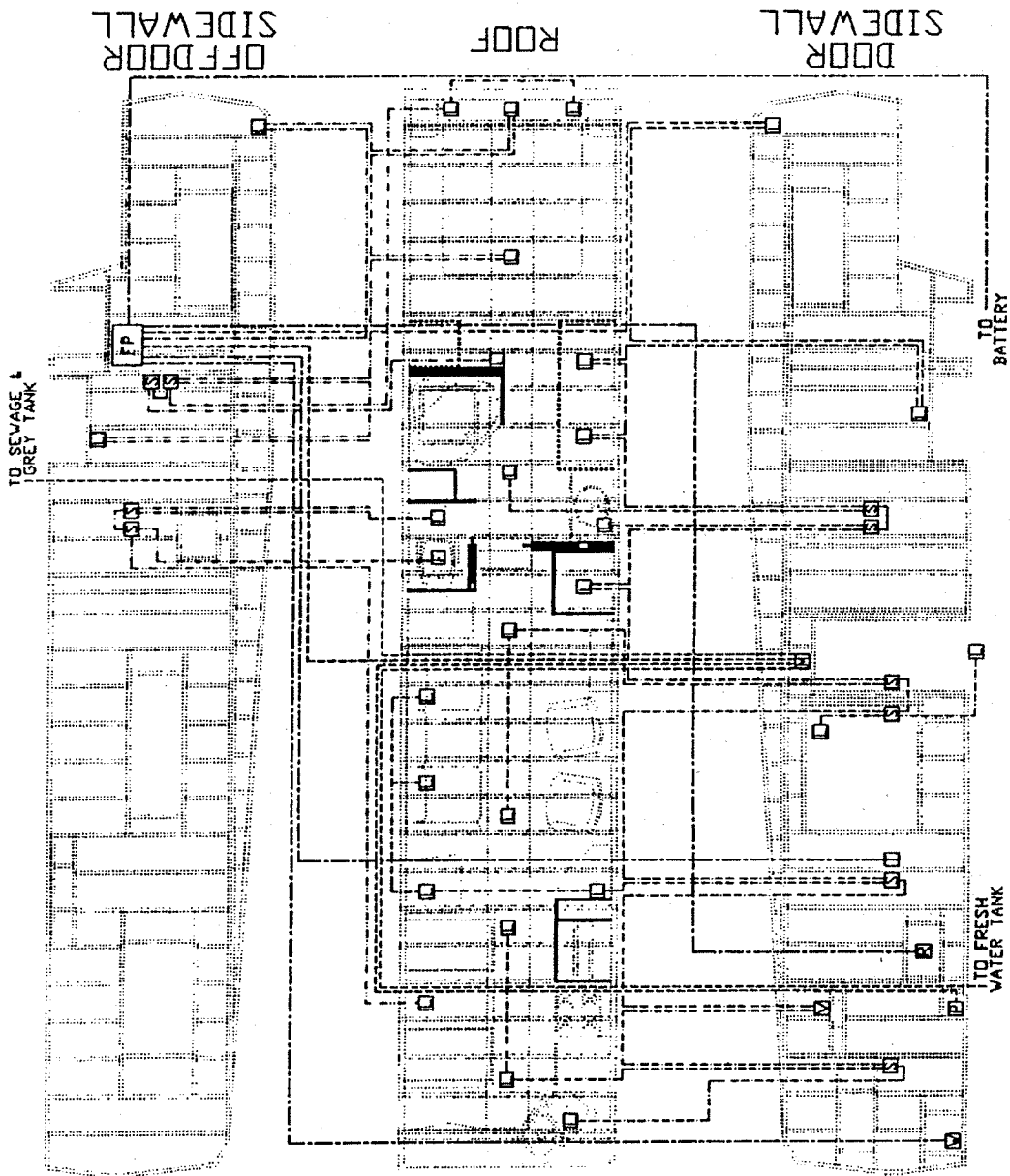

- L - LIGHT
- S - SWITCH
- T - TV JACK
- V - RANGE VENT FAN
- R - REFRIGERATOR
- W - WHEATER (REIGNITOR OPT.)
- M - MONITOR PANEL
- F - BATH VENT FAN
- FP - FUSE PANEL
- P - WATER PUMP

- MONITOR LINE
- DOOR SIDE
- OFF DOOR SIDE
- INDIVIDUAL LINE

NOTE:

ALL WIRES SHOWN DO NOT NECESSARILY RUN THROUGH A SPECIFIC STUD. THIS PRINT SHOWS GENERAL LOCATIONS OF WIRES ONLY.

TYPICAL FRESH WATER DIAGRAM

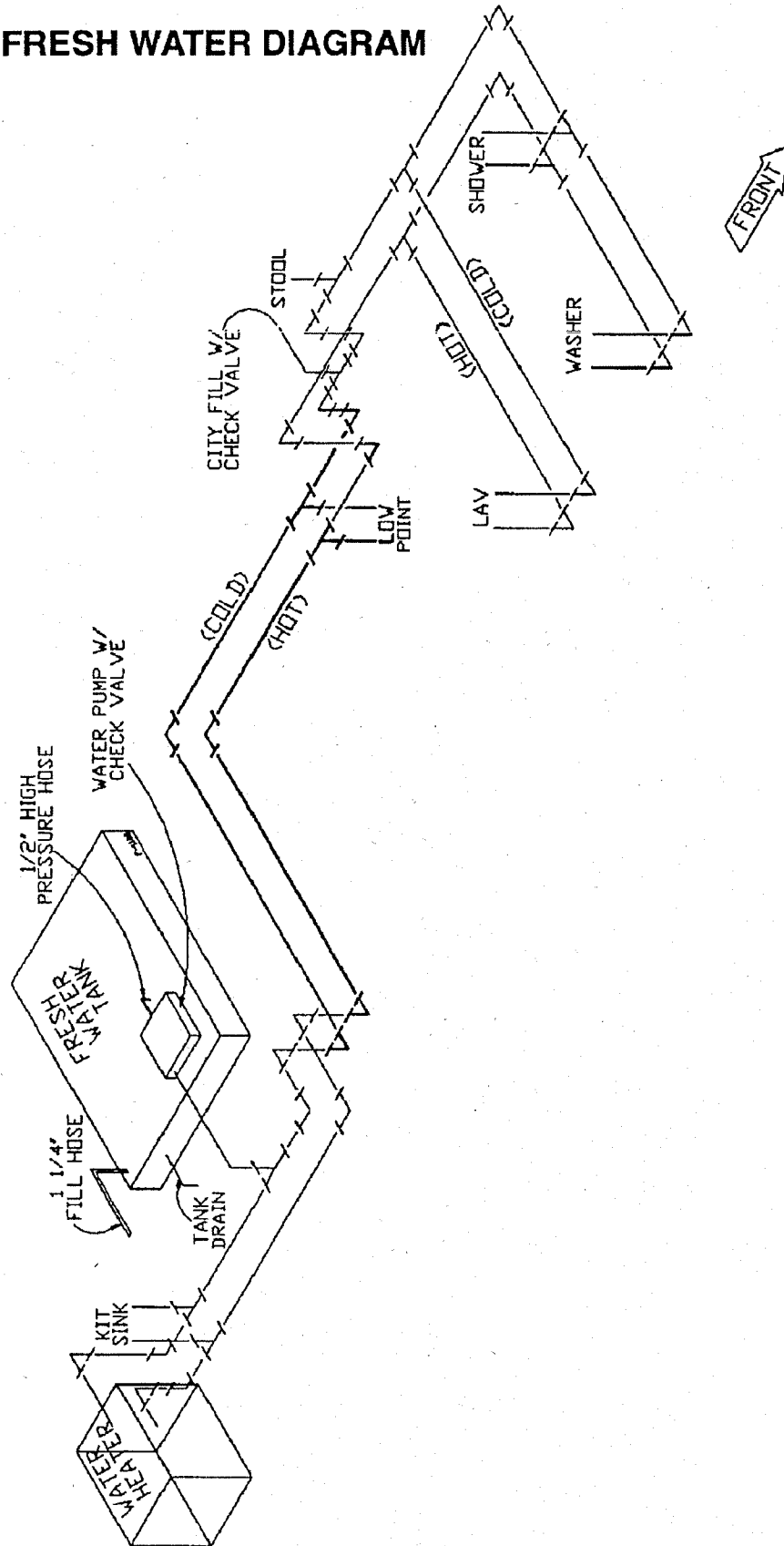

TYPICAL DRAIN LINE DIAGRAM

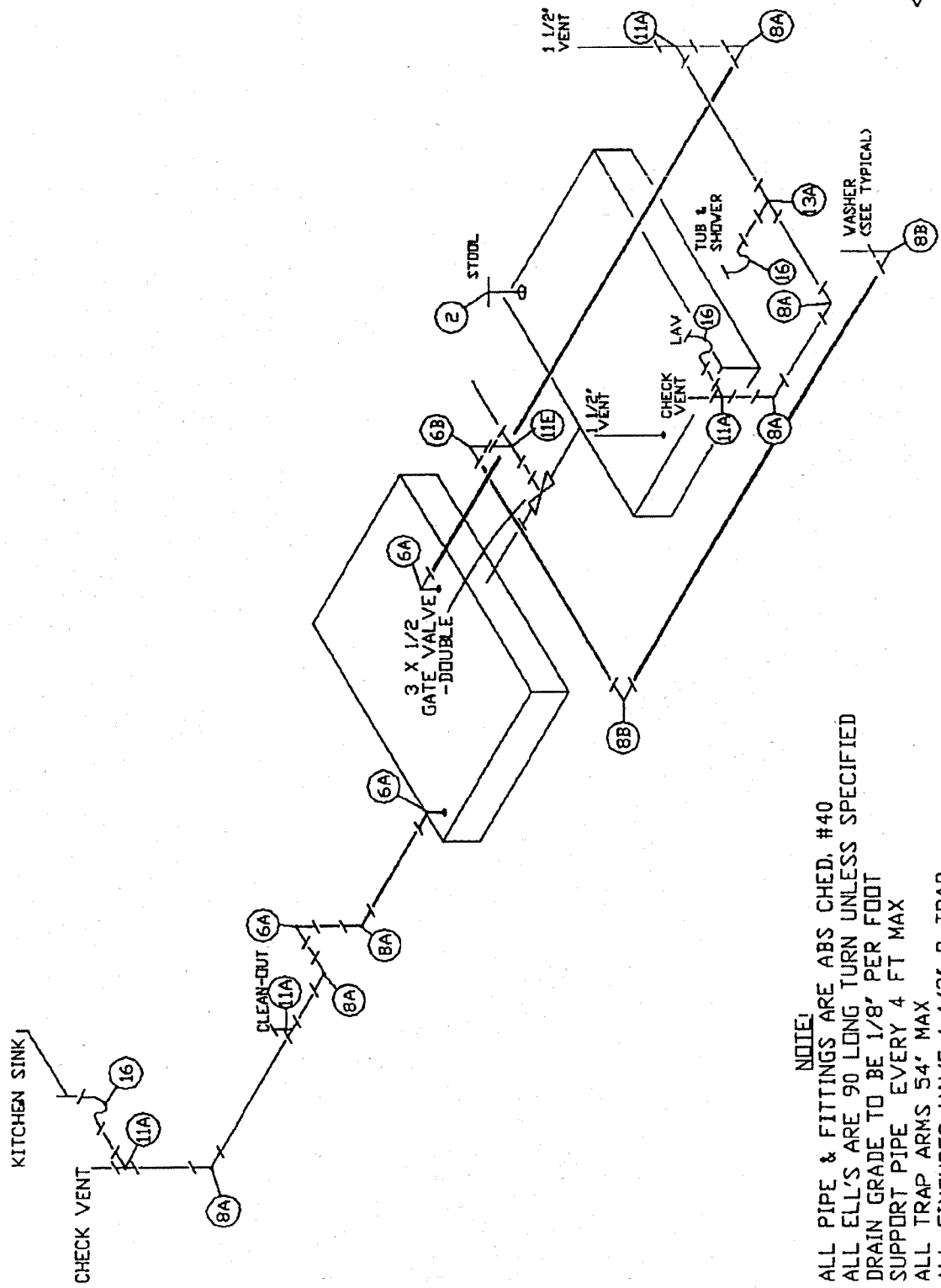

NOTE!
 ALL PIPE & FITTINGS ARE ABS CHED, #40
 ALL ELL'S ARE 90 LONG TURN UNLESS SPECIFIED
 DRAIN GRADE TO BE 1/8" PER FOOT
 SUPPORT PIPE EVERY 4 FT MAX
 ALL TRAP ARMS 54" MAX
 ALL FIXTURES HAVE 1 1/2" P-TRAP
 ALL TANK HOOK-UPS ASE A DOUBLE LITTY UNLESS SPECIFIED OTHERWISE
 BELOW FLOOR PLUMBING

SLIDE-OUT MECHANISM

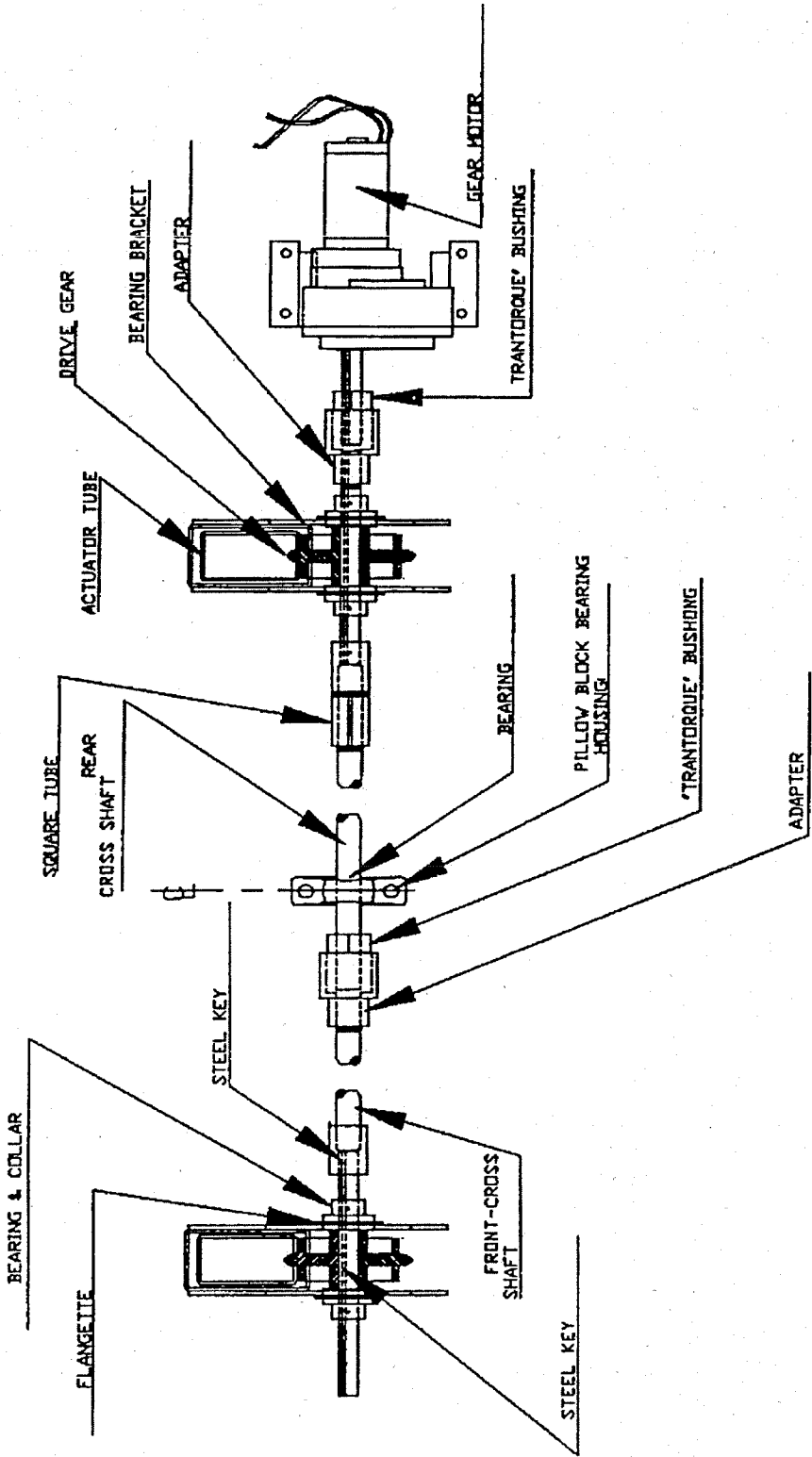

London Aire Towable	Description	Item #
	Antenna, TV	QD 18380
	Door, Main Entrance	ID 30129
	Door, Furnace	QC 21868
	Door, Refer Vent	QF 30100
	Door, Water Heater	QG 24915
	Faucet, Lav	CM 24645
	Faucet, Kitchen, Sgl HdI	CM 24644
	Faucet, Shower	CM 17200
	Grab Handle, Acrylic, Door	NA 16229
	Ladder	NA 30147
	Light, Brake	EH 29685
	Light, Scare	EH 10674
	Recept, 12 Volt, White	EB 10641
	Recept, 120 Volt, White	EB 10551
	Recept, GFCI	EB 10553

London Aire Towable	Description	Item #
	Recept, GFCI	EB 10553
	Register, Floor	QC 12292
	Register, Ceiling	QC 22580
	Roof Rack	NA 11820
	Sink Cover	NA 25138
	Skylight	IS 14607
	Step, Kwikkee	ID 26468
	Switch, 12 Volt, Double, White	EB 24810
	Switch, 12 Volt, Single, White	EB 24809
	Switch, 12 Volt, Triple, White	EB 24811
	Switch, 120 Volt, White	EB 10543
	Switch, 120 Volt, Brown	EB 10542
	T-Stat, Dometic	QA 27782
	T-Stat, FanTastic Vent	IS 1513