

# NEW MAR

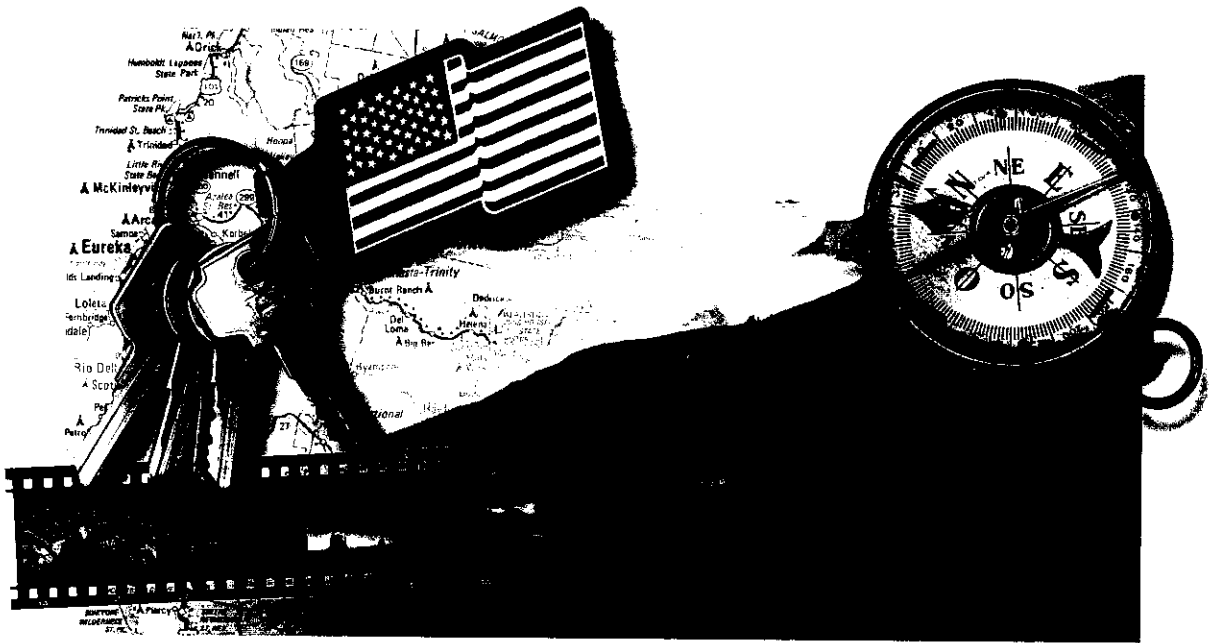

# OWNER'S GUIDE

*1999 London Aire*

FIFTH WHEEL

# NEWMAR CORPORATION OWNER'S GUIDE

## *Table of Contents*

Chapter 1	General Information
Chapter 2	Towing & Safety Precautions
Chapter 3	Air Conditioning & Heating
Chapter 4	Appliances & Accessories
Chapter 5	Cabinets & Furniture
Chapter 6	Structure Features
Chapter 7	Electrical Features
Chapter 8	Slide Out Features
Chapter 9	Exterior Features
Chapter 10	Interior Features
Chapter 11	Plumbing & Bath Features
Chapter 12	Construction Features
Chapter 13	Windows, Awnings, Vents & Doors
Chapter 14	Routine Maintenance
Chapter 15	Charts & Diagrams

Welcome to the exciting world of RV traveling and the growing family of recreational vehicle owners.

Congratulations on your purchase of a Newmar product. We sincerely thank you for choosing Newmar as your recreational vehicle. We trust this guide will help you to better understand and enjoy your new RV. We hope that you will enjoy many miles of traveling. Your new vehicle was built with care using today's technology and old world craftsmanship. We, at Newmar, strive to build vehicles that are safe, dependable, and comfortable to provide years of carefree, pleasant traveling.

This Owner's Guide, along with the Video Guide, should be kept in your vehicle for quick reference. Take time to get acquainted with your unit and how it operates. Carefully read both the instructions in this guide and the booklets supplied by the component manufacturers for important operation, safety, and maintenance information. Your dealer should be consulted should you have any questions. If your dealer is unable to answer the questions to your satisfaction he will refer you to our staff for help. Our customers are extremely important to us and we will make every effort necessary to ensure your satisfaction.

Again, thank you and welcome to our Newmar family.

*Newmar Corporation*



1999 London Aire Fifth Wheel

This guide, along with the Video Owner's Guide, has been provided by Newmar Corporation solely for the purpose of providing instructions about the operation and maintenance of this vehicle and its components. Nothing in this manual creates any warranty, either express or implied. The only warranty offered by Newmar Corporation is set forth in the written limited warranty that applies to this vehicle.

Instructions are included in this manual for operating some of the components that are standard on this vehicle. Instructions are also given for components that are options and may not appear on all vehicles. For more detailed information on components refer to the individual manufacturer's operating instructions contained in the Owner's Information Package.

The limited warranties issued by component manufacturers require periodic service and maintenance, and the owner's failure to provide this service and/or maintenance will result in the loss of warranty coverage. The owner should review the Newmar Corporation limited warranty and other manufacturers limited warranties of all components applicable to this vehicle. To activate the warranties on the components within your Newmar recreational vehicle, be sure to file the appropriate registration card with the component manufacturer as described with the individual instruction booklet.

Newmar Corporation has compiled the most current information available at the time of publication. If the components in your unit vary significantly from what is described within this manual, then consult the instructions provided by the component manufacturer found in the Owner's Package.

Throughout this guide, reference is made to the following terms: Warning, Caution, and Important. These terms indicate important information that must be understood and followed. The definitions of these terms are:

#### **WARNING**

Emphasizes an area in which personal injury or even death could result from failure to follow instructions properly. Mechanical damage may also occur.

#### **CAUTION**

Failure to observe a caution can cause damage to the equipment or unit. Personal injury is unlikely.

#### **IMPORTANT**

Provides additional information to make a step easier or clearer.



# CHAPTER 1

## GENERAL INFORMATION

### *Table of Contents*

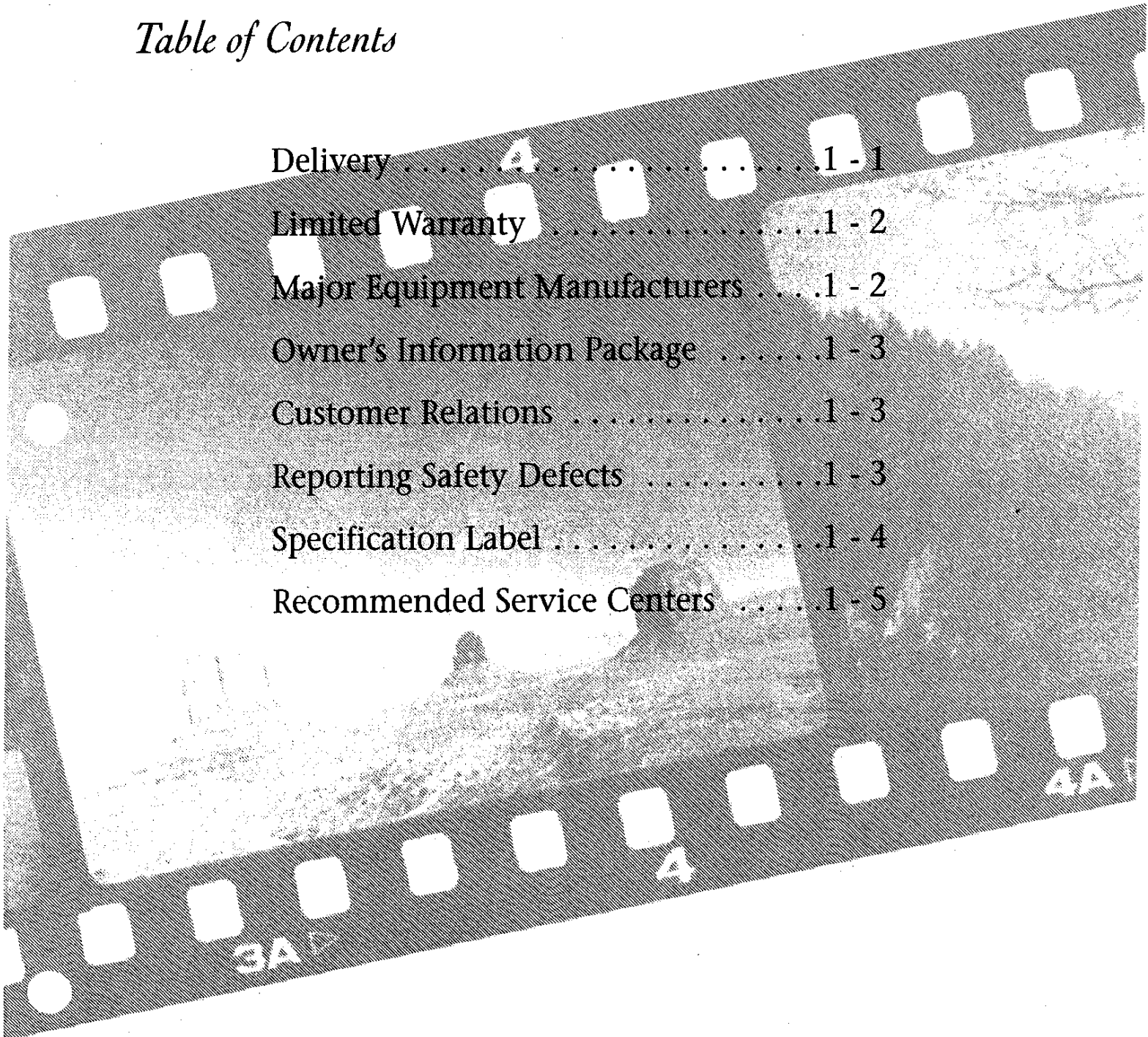

Delivery . . . . .	1 - 1
Limited Warranty . . . . .	1 - 2
Major Equipment Manufacturers . . . . .	1 - 2
Owner's Information Package . . . . .	1 - 3
Customer Relations . . . . .	1 - 3
Reporting Safety Defects . . . . .	1 - 3
Specification Label . . . . .	1 - 4
Recommended Service Centers . . . . .	1 - 5

# DELIVERY

Throughout the manufacturing process, your vehicle has been inspected by our qualified technicians. However, our final inspection at the factory is not to be the last one. The pre-delivery inspection and systems check your dealer performs are the final inspections done to the unit prior to you receiving your new coach. Your dealer is also available to assist you in understanding the limited warranties and completing any necessary forms to activate the warranties for the various appliances and accessories installed in your unit.

## *Dealer Responsibilities*

1. A pre-delivery inspection and systems check. Thoroughly inspecting the vehicle and the operation of the factory installed components.
2. A customer walk through. This is done to familiarize the customer with the vehicle, its systems and components, and their operation.
3. Delivery of the Owner's Information Package. This package contains the warranty cards and registrations for the vehicle and factory installed components that carry a separate warranty. The detailed operating and maintenance instructions on these components are also included in this package.
4. Assisting the customer in completing the component registration forms, at the customer's request. To avoid loss of warranty coverage, the dealer should review the limited warranty provisions with the customer stressing the importance of filing warranty cards and registrations to the component's manufacturers within the prescribed time limit.
5. Providing the customer with information regarding warranty and non-warranty work on the vehicle and its separately warranted components whether the customer is in or out of the area.

## *Customer Responsibilities*

The customer is responsible for regular and proper maintenance of the vehicle. Properly maintaining your vehicle will prevent conditions arising from neglect that are not covered by your Newmar limited warranty. The maintenance guidelines in this manual and any other applicable manual should be followed. It is your responsibility and obligation to return the vehicle to an authorized dealer for repairs and service.

To assist you in avoiding problems with your vehicle, we recommend you do the following:

- a. Read the warranty. Go over it thoroughly with your dealer.
- b. Inspect the vehicle. Do not accept delivery until you have gone through the unit with the dealer. Newmar has provided a check list to be used during retail delivery. Check each item on the list and make sure he does the same. Do not sign this checklist until you have done this.
- c. Ask questions about anything that you do not understand concerning your recreational vehicle.
- d. When taking delivery, set an appointment for adjustments. This appointment should be approximately two (2) weeks after you accept delivery.

# RECREATIONAL VEHICLE LIMITED WARRANTY

The Newmar Corporation Limited Warranty was provided to you by your selling dealer prior to purchase. Please refer to this document when inquiring about the Newmar Warranty. To receive an additional copy, please write to: Newmar Corporation, Warranty Department, P.O. Box 30, Nappanee, IN 46550-0030.

## *Major Equipment Manufacturers*

Atwood (Water Heater & LP Detector) . . . . .	800-847-7160
Carefree Awnings . . . . .	800-621-2617
Dexter Axle . . . . .	219-295-1900
Dometic, Duo Therm . . . . .	800-544-4881
Excide Battery . . . . .	800-537-9434
Fantastic Vents . . . . .	800-521-0298
Flexsteel . . . . .	319-556-7730
Gekotek Electronics (Monitor Panel) . . . . .	714-738-3551
Goodyear Tires . . . . .	800-227-1999
Kwikke Products (Step) . . . . .	800-736-9961
Magnadyne . . . . .	219-262-4479
Magnavox Appliances . . . . .	800-531-0039
Moen Faucets . . . . .	800-321-8809
Mor/Ryde Suspension . . . . .	219-293-1581
Newmar Corporation . . . . .	800-731-8300
Onan Generators . . . . .	800-888-6626
Pioneer Stereo . . . . .	800-777-4856
Princess Range . . . . .	303-659-8221
Sealand Toilets . . . . .	800-321-9886
Sears Washer & Dryer . . . . .	800-359-2000
Sharp . . . . .	800-237-4277
Sony (IN Only) . . . . .	219-522-7781
Sony (Other) . . . . .	800-442-7717
Splendide (1-Piece Washer/Dryer) . . . . .	504-229-4922
Suburban Furnace . . . . .	800-659-2138
Todd Engineering . . . . .	219-293-8633
Trekmate Security Systems . . . . .	619-941-3444
U-Line Ice Maker . . . . .	800-779-2547
Ventline (Range Hood) . . . . .	219-848-4491
Wilsonart Flooring . . . . .	219-848-4408
Winegard Antenna Systems . . . . .	800-288-8094

## *Owner's Information Package*

Included in this package are valuable documents about your vehicle and its components and systems. The Newmar Owner's Guide does not cover every possible detail of equipment, standard and/or option, installed on or in your vehicle. Consulting the booklets and instruction manuals in this package will help you safely operate, maintain, and troubleshoot these items.

Read all of the information and understand the safety and operating instructions included in the Owner's Information Package. To assure full warranty coverage, it is essential that all maintenance instructions are followed.

## CUSTOMER RELATIONS

If you wish to schedule maintenance, service or to order parts, you should notify your local Authorized Newmar Service Center to set up an appointment. If you are unsure of the location of your closest Authorized Newmar Service Center, see the listing in the manual. You may also write to:

Newmar Corporation  
Warranty Department  
P.O. Box 30  
Nappanee, IN 46550-0030

## REPORTING SAFETY DEFECTS

If you believe that your vehicle has a defect which could cause a crash or could cause injury or death, you should immediately inform the National Highway Traffic Safety Administration (NHTSA) in addition to notifying Newmar Corporation.

If NHTSA receives similar complaints, it may open an investigation, and if it finds that a safety defect exists in a group of vehicles, it may order a recall and remedy campaign. However, NHTSA cannot become involved in individual problems between you, your dealer, or Newmar.

To contact NHTSA, you may either call the Auto Safety Hotline toll free at 1-800-424-9393 (or 366-0123 in Washington, D.C. area) or write to: NHTSA, U.S. Department of Transportation, Washington, DC 20590. You can also obtain other information about motor vehicle safety from the Hotline.

# SPECIFICATION LABEL

There are two main numbers used to identify the vehicle. The Vehicle Identification Number (VIN) is the legal identification of the completed vehicle. The VIN is the number used by the state for vehicle registration. The Newmar Serial Number (1) is a five digit number that is needed whenever making an appointment for service or ordering parts through your Newmar Dealer or Service Center. This number can be found on the placard in the kitchen overhead and on the Customer Care card received from Newmar. Below is a sample of the placard located in the kitchen.

1. The Newmar Serial Number.
2. Last five digits Vehicle Identification Number (VIN)
3. Model Number of the Unit
4. Model Year of the Unit
5. Manufacturer, Model Number, and Serial Number of factory-installed appliances

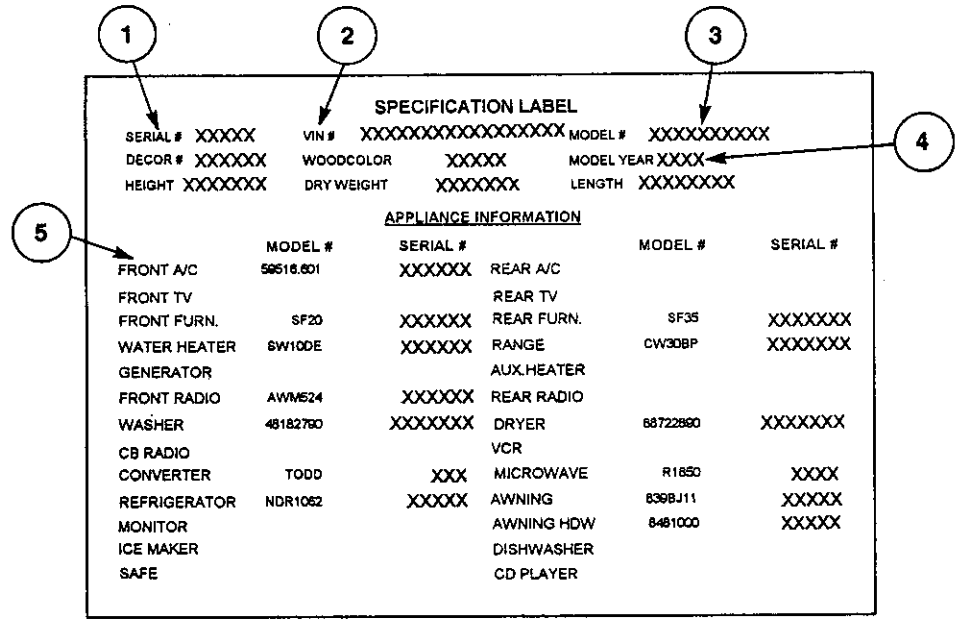

## Notes

---

---

---

---

---

---

---

---

---

---

# RECOMMENDED SERVICE CENTERS

## ALABAMA

MADISON RV CENTER INC.  
1707 Jordan Lane NW  
Huntsville, AL 35816  
(205)837-3881 Fax (205)830-4451

MILLICAN RV AMERICA INC.  
36115 U.S. Highway 280  
Sylacauga, AL 35150  
(205)249-3773 Fax (205)249-3958

## ALASKA

ALASKAN ADVENTURES RV CENTER  
918 E. 73rd Street  
Anchorage, AK 99523  
(907)344-2072 Fax (907)344-1608

## ARIZONA

AMERICAN PRIDE RV CENTER  
2145 E. Main  
Mesa, AZ 85213  
(602)644-1500 Fax (602)644-0293

LA MESA RV CENTER  
6651 Gila Ridge Road  
Yuma, AZ 85364  
(520)344-4900 Fax (520)317-9355

## ARKANSAS

OUTDOOR LIVING CENTER  
Highway 7 South, P.O. Box 1081  
Russellville, AR 72801  
(501)968-7706 Fax (501)968-4360

## CALIFORNIA

ALPINE RECREATION SALES & SERVICE  
19380 Monterey Road  
Morgan Hill, CA 95037  
(209)824-1437 Fax (209)824-1437

BARBER RV INC.  
3650 E. Main Street, P.O. Box 3318  
Ventura, CA 93006  
(805)642-0276 Fax (805)642-9711

BRAWLEYS  
5933 N. McHenry Ave., P.O. Box 2036  
Manteca, CA 95336  
(209)521-0170 Fax (209)521-9436

DAVE ALTMAN'S RV CENTERS  
1201 Baldwin Park Boulevard  
Baldwin Park, CA 91706  
(626)960-1884 Fax (626)962-6906

DAVE ALTMAN'S RV CENTERS  
1313 RV Center Drive  
Colton, CA 92324  
(909)422-0311 Fax (909)422-0450

DAVE ALTMAN'S RV CENTERS  
22020 Recreation Road  
Carson, CA 90745  
(310)518-6182 Fax (310)513-0500

EL MONTE RV CENTER  
12061 E. Valley Boulevard  
El Monte, CA 91732  
(626)443-6158 Fax (626)404-6386

EL MONTE RV CENTER  
565 E. Redlands Boulevard  
San Bernardino, CA 92402  
(909)885-2000 Fax (909)888-0420

LA MESA RV CENTER  
7430 Copley Park Place  
San Diego, CA 92111  
(619)874-8000 Fax (619)874-8032

LA MESA RV CENTER  
5200 Chiles Road  
Davis, CA 95616  
(530)750-5070 Fax (530)750-5660

## COLORADO

ALPINE TRAVEL TRAILERS, INC.  
2487 Highway 6 & 50  
Grand Junction, CO 81505  
(970)242-5898 Fax (970)242-5898

HENRY'S AUTO & TRUCK CENTER  
6601 Del Sol Drive  
Alamosa, CO 81101  
(719)587-0084

JDL TRAILER SALES  
2734 Lake Avenue  
Pueblo, CO 81004  
(719)564-8056 Fax (719)564-0306

MOUNTAIN STATES RV, INC.  
14300 E. Colfax Avenue  
Aurora, CO 80011  
(303)360-0252 Fax (303)363-9103

## CONNECTICUT

DAVE'S RV CENTER  
2 Industrial Plaza Road  
Danbury, CT 06810  
(203)730-1744 Fax (203)730-1741

## FLORIDA

DICK GORE'S R.V. WORLD  
14590 Duval Place West  
Jacksonville, FL 32218  
(904)741-5100 Fax (904)741-4905

INDEPENDENCE RV SALES & SVC. INC.  
12705 W. Colonial Drive  
Winter Garden, FL 34787  
(407)877-7878 Fax (407)877-3806

LAND YACHTS INC.  
1414 Commerce Lane, P.O. Box 1840  
Jupiter, FL 33468  
(561)745-0242 Fax (561)745-1725

LEISURE TYME RV, INC.  
1490 Highway 98 W.  
Mary Esther, FL 32569  
(850)581-0880 Fax (850)581-2300

LEISURE TYME RV INC.  
6428 Pensacola Boulevard  
Pensacola, FL 32505  
(850)476-6848 Fax (850)474-6392

NORTH TRAIL RV CENTER  
5270 Orange River Boulevard  
Ft Myers, FL 33905  
(941)693-8200 Fax (941)693-9702

TRAVEL EASY RV INC.  
4299 Highway 441 S.  
Okeechobee, FL 34974  
(941)467-0400 Fax (941)467-9396

TRI AM RV CENTER INC.  
5441 N.E. Jacksonville Road  
Ocala, FL 34479  
(352)732-6269 Fax (352)368-7992

## GEORGIA

C.S.R.A. CAMPERLAND INC.  
3844 Washington Road  
Martinez, GA 30907  
(706)863-6294 Fax (706)860-5728

COACH & CAMPERS RV SERVICE CENTER  
7656 Old Covington Highway  
Lithonia, GA 30058  
(770)482-4666 Fax (770)482-2026

## IDAHO

AMERICAN WAY RV CENTER  
dba Northwest Recreational Vehicle, Inc.  
4033 Chinden Boulevard  
Boise, ID 83714  
(208)345-6644 Fax (208)345-5540

## ILLINOIS

ALL SEASONS CAMPING INC.  
260 W. Grand Avenue  
Elmhurst, IL 60126  
(630)832-0800 Fax (630)832-0838

COLLIER RV CENTER  
3510 Merchandise Drive  
Rockford, IL 61109  
(815)874-7188 Fax (815)874-9426

LARRY'S TRAILER SALES INC.  
Highway 148 N., P.O. Box 98  
Zeigler, IL 62999  
(618)596-6414 Fax (618)596-6344

OZARK COACH SALES  
707 Macomb St., P.O. Box 354  
Colchester, IL 62326  
(309)776-3182 Fax (309)776-3183

R & S SALES & SERVICE, INC.  
218 S. Lake of the Woods Road  
Mahomet, IL 61853  
(217)586-2055 Fax (217)586-2382

## INDIANA

DON'S CAMPER SALES INC.  
U.S. 41 S, Box 373  
Boswell, IN 47921  
(765)869-5009 Fax (765)869-5009

HART CITY RV SERVICE INC.  
2301 S. Nappanee Street  
Elkhart, IN 46517  
(219)295-5793 Fax (219)295-6190

INDY RV CENTER INC.  
State Rd. 37, S. Smith Valley Rd., P.O. Box 447  
Greenwood, IN 46142  
(317)881-0300 Fax (317)881-0431



**PREMIER RV INC.**

1400 Leisure Way  
Clarksville, IN 47129  
(812)284-1400 Fax (812)283-3465

**THE RV CENTER INC.**

3360 E. Lincolnway  
Columbia City, IN 46725  
(219)244-3414 Fax (219)244-3898

**TERRY'S RV SALES & SERVICE**

dba Terryman Inc.  
2900 East CR 350 North  
Muncie, IN 47303  
(765)289-9704 Fax (765)289-9737

**TOM STINNETT HOLIDAY RV CTR. INC.**

520 Marriott Drive  
Clarksville, IN 47129  
(812)282-7718 Fax (812)285-7578

**WETNIGHT RV SALES & SERVICE INC.**

4401 U.S. 41 N., P.O. Box 5197  
Terre Haute, IN 47805  
(812)466-3961 Fax (812)466-6851

**IOWA****HEROLD TRAILER SALES**

1806 W. 2nd Ave., Highway 92 W.  
Indianola, IA 50125  
(515)961-7405 Fax (515)961-3674

**WALKER TRAILER SALES, INC.**

Highway 18 W., Box 633  
Nora Springs, IA 50458  
(515)749-2321 Fax (515)749-2321

**KANSAS****HARPER CAMPERLAND INC.**

1200 E. 10th, P.O. Box 1993  
Great Bend, KS 67530  
(316)792-5170 Fax (316)792-8466

**HARPER CAMPERLAND INC.**

117 W. 14th  
Harper, KS 67058  
(316)896-2862 Fax (316)896-2858

**JAYHAWK CAMPER SALES**

24105 W. 43rd  
Shawnee, KS 66226  
(913)422-5677 Fax (913)422-7147

**WILCOX HOMES & RV CENTER**

835 N.E. Highway 24  
Topeka, KS 66608  
(913)357-5111 Fax (913)232-1574

**KENTUCKY****HALL ENTERPRISES, INC.**

975 Beasley Street, P.O. Box 55038  
Lexington, KY 40555  
(606)233-1777 Fax (606)254-1073

**YOUNGBLOOD RV CENTER INC.**

2132 St. Rt. 45 N.  
Mayfield, KY 42066  
(502)247-8591 Fax (502)247-0604

**LOUISIANA****JACKIE EDGAR RV CENTER INC.**

3018 N.E. Evangeline Thruway  
P.O. Box 90274  
Lafayette, LA 70507-3425  
(318)232-1941 Fax (318)232-1950

**MILLER RV**

12912 Florida Boulevard  
Baton Rouge, LA 70815  
(504)275-2940 Fax (504)275-6807

**MAINE****MOUNTAIN ROAD RV**

R.F.D. #1, Box 2620  
Sabattus, ME 04280  
(207)375-4091 Fax (207)375-4014

**MARYLAND****BECKLEY'S CAMPING CENTER**

11109 Angleberger Road  
Thrumont, MD 21788  
(301)898-3300 Fax (301)898-1017

**MICHIGAN****BEECH GROVE TRAILER SALES**

51439 M40 North  
Marcellus, MI 49067  
(616)646-7845 Fax (616)646-2012

**GAYLORD RV SALES & SERVICE**

271 W. Johnson Road  
Gaylord, MI 49735  
(517)732-6141 Fax (517)731-2735

**GENERAL TRAILER SALES**

5300 Highland Road  
Waterford, MI 48327  
(248)674-0346 Fax (248)674-3809

**GENERAL TRAILER SALES**

48500 12 Mile Road  
Wixom, MI 48393  
(248)349-0900 Fax (248)349-7965

**HILLTOP RV**

2905 N. Lincoln Road  
Escanaba, MI 49829  
(906)786-7986 Fax (906)786-3421

**KITSMILLER RV INC.**

1211 N. Cedar  
Mason, MI 48854  
(517)694-7500 Fax (517)694-3542

**MIDWAY MOTORHOMES INC.**

5590 S. Division Avenue  
Grand Rapids, MI 49548  
(616)534-9641 Fax (616)534-6869

**MODERN TRAILER SALES, INC.**

3449 S. Division Avenue  
Wyoming, MI 49548-2110  
(616)241-2925 Fax (616)241-5451

**MINNESOTA****HILLTOP TRAILER SALES**

4560 Center Avenue N.E.  
Minneapolis, MN 55421  
(612)571-9103 Fax (612)571-2536

**SHOREWOOD RV CENTER**

8390 Highway 10 N.W.  
Anoka, MN 55303  
(612)421-2505 Fax (612)421-6076

**MISSISSIPPI****RV REPAIR & SALES, INC.**

4749 Highway 80 W.  
Jackson, MS 39209  
(601)922-9425 Fax (601)922-5153

**MISSOURI****THOMAS BILL CAMPER SALES INC.**

5217 N. Lindbergh  
St Louis, MO 63044  
(314)731-2217 Fax (314)731-0269

**CAPETOWN RV SALES**

I-55 & Airport Road, P.O. Box 1985  
Cape Girardeau, MO 63702  
(573)334-7152 Fax (573)334-9059

**COACHLIGHT RV SALES INC.**

5327 S. Garrison Ave.  
Carthage, MO 64836  
(417)358-7444 Fax (417)358-0856

**FRANK REED RV INC.**

Hwy 47 North, P.O. Box 212  
St. Clair, MO 63077  
(314)583-2244 Fax (314)583-2147

**KC TRAILER SALES, INC.**

11520 S. 71 Highway  
Kansas City, MO 64137  
(816)761-1393 Fax (816)761-7722

**MONTANA****BRETZ RV & MARINE**

2045 Mullen Road  
Missoula, MT 59802  
(406)721-4010 Fax (406)549-8078

**NEBRASKA****RICH & SON'S CAMPER SALES**

5112 S. Antelope Drive  
Grand Island, NE 68803  
(308)384-2040 Fax (308)384-2043

**NEVADA****MC KINNISH AUTO SALES & LSN INC.**

5130 Highway South east  
Carson city, NV 89706  
(702)883-7834 Fax (702)883-8196

**WHEELERS LAS VEGAS RV**

13175 Las Vegas Boulevard S.  
Las Vegas, NV 89124  
(702)896-9000 Fax (702)896-4504

**WINKEL PONTIAC GMC RV CENTER**

900 Kietzke Lane  
Reno, NV 89502  
(702)329-0831 Fax (702)323-6272

## NEW HAMPSHIRE

C. H. DANA RV SALES & SERVICE  
628 Woodsville Road  
Monroe, NH 03771-3328  
(603)638-2200 Fax (603)638-2066

### CAMP AMERICA INC.

222 Plaistow Rd., Rte. 125  
Plaistow, NH 03865  
(603)382-9296 Fax (603)382-1060

### CAMPERS INN OF KINGSTON

146 Route 125  
Kingston, NH 03848  
(603)642-5555 Fax (603)642-9931

### MOUNTAIN VALLEY RECREATION

410 Main Street  
Gorham, NH 03581  
(603)466-3868 Fax (603)466-2416

## NEW JERSEY

### SCOTT MOTOR COACH SALES INC.

1133 Route 88  
Lakewood, NJ 08701  
(732)370-1022 Fax (732)905-0993

## NEW MEXICO

### ALOHA RV INC.

11200 Central S.E., P.O. Box 53250  
Albuquerque, NM 87123  
(505)298-8444 Fax (505)275-7687

### AMERICAN RV & MARINE

11810 Central S.E.  
Albuquerque, NM 87123  
(505)293-1983 Fax (505)293-6991

### AMERICAN RV & MARINE

200 N. Telshore Boulevard  
Las Cruces, NM 88011  
(505)522-5512 Fax (505)522-3781

## NEW YORK

### BALLARDS CAMPING CENTER, INC.

S-5849 Southwestern Blvd.  
Hamburg, NY 14075  
(716)649-9654 Fax (716)648-0340

### FREEDOM RV OUTLET

103 Sitterly Road  
Clifton Park, NY 12065  
(518)581-7701 Fax (518)581-0037

### NORTHWAY TRAVEL TRAILERS INC.

2570 Route 9, P.O. Box 2110  
Ballston Spa, NY 12020  
(518)899-2526 Fax (518)899-6735

### SEVEN O'S

7917 Devaul Road  
Kirkville, NY 13082  
(315)687-9342 Fax (315)687-7992

### WES TRAILER SALES

6166 Route 25  
Wading River, NY 11792  
(516)727-5852 Fax (516)727-5396

### WILKENS RV INC.

1099 Almond Road  
Hornell, NY 14843  
(607)324-1313 Fax (607)324-1082

## WRATTEN TRAILER SALES

9209 Route 11 S., P.O. Box 5  
Adams, NY 13605  
(315)232-4535 Fax (315)232-3445

## NORTH CAROLINA

### HOWARD RV CENTER

6811 Market Street  
Wilmington, NC 28405  
(910)791-5371 Fax (910)392-0672

### INDEPENDENCE RV SALES LOT #2

6600 Reames Road  
Charlotte, NC 28216  
(704)596-5600 Fax (704)597-7400

### OLD TOWN CAMPER SALES, INC.

5109 N. Causeway Drive  
Winston-Salem, NC 27106  
(336)924-9864 Fax (336)922-1458

### RANDYS RV'S INC.

4904 T.V. Tower Road  
Garner, NC 27529  
(919)779-5445 Fax (919)772-8142

## NORTH DAKOTA

### CAPITAL RV CENTER, INC.

1900 N. Bismarck Expressway  
Bismarck, ND 58501  
(701)255-7878 Fax (701)255-1678

## OHIO

### AMOS MOTOR & RV, INC.

109 S. Main St., P.O. Box 555  
Bradner, OH 43406  
(419)288-2700 Fax (419)288-3273

### BEGGS MOTOR HOMES, INC.

11197 Cleveland Ave. N.W., P.O. Box 545  
Uniontown, OH 44685  
(330)499-9755 Fax (330)499-6002

### COLERAIN TRAILER CENTER INC.

3491 Struble Road  
Cincinnati, OH 45251  
(513)923-3600 Fax (513)245-5145

### FARBER MOTORS INC.

5858 Scarborough Blvd.  
Columbus, OH 43232  
(614)864-7878 Fax (614)864-7899

## OKLAHOMA

### DAVE'S CLAREMORE RV INC.

1400 S. Lynn Riggs  
Claremore, OK 74017  
(918)341-0114 Fax (918)341-8936

### LEE'S RV CITY INC.

13111 N. Broadway Ext., P.O. Box 6250  
Edmond, OK 73083-6250  
(405)936-9300 Fax (405)936-9323

### LEWIS TRAVEL TRAILER SALES

11518 E. 66th Street  
Owasso, OK 74055  
(918)272-1353 Fax (918)272-5451

## OREGON

### AL'S TRAILER SALES OF SALEM

4843 Portland Road N.E.  
Salem, OR 97305  
(503)393-3365 Fax (503)393-1525

### CURTIS TRAILERS, INC.

21525 S.W. T.V. Highway  
Aloha, OR 97006  
(503)649-8528 Fax (503)649-3974

### CURTIS TRAILERS, INC.

10177 S.E. Powell  
Portland, OR 97266  
(503)760-1363 Fax (503)760-1482

### EUGENE RECREATION SALES INC.

1700 Highway 99 N.  
Eugene, OR 97402  
(541)688-4849 Fax (541)688-1885

### HOST RV SERVICE & SALES CENTER

90712 Huntley Court  
Coburg, OR 97408  
(541)345-6790 Fax (541)345-6713

### OLINGER TRAVEL HOMES, INC.

6503 Alexander  
Hillsboro, OR 97123  
(503)649-2141 Fax (503)642-9579

### OLINGER TRAVEL HOMES, INC.

9401 South East 82nd  
Portland, OR 97266  
(503)771-2121 Fax (503)771-4638

### RV ROUNDUP

2790 Crater Lake Hwy.  
Medford, OR 97504  
(541)770-5887 Fax (541)770-5589

### TRIPLE A RV CENTER, INC.

938 Chevy Way  
Medford, OR 97504  
(541)772-1938 Fax (541)779-1460

## PENNSYLVANIA

### ANSLEY & LEWIS, INC.

1280 Route 764, P.O. Box 239  
Duncansville, PA 16635  
(814)695-9817 Fax (814)695-9814

### COUNCIL CUP TRAILER SALES

Route 239  
Wapwallopen, PA 18660  
(717)379-3751 Fax (717)379-2913

### HAROLD'S RV CENTER

7514 Beth Bath Pike  
Bath, PA 18014  
(610)837-9880 Fax (610)837-9473

### ROLLING WHEELS RV

2314 Lycoming Creek Road  
Williamsport, PA 17701  
(717)322-1894 Fax (717)322-1902

## RHODE ISLAND

### ARLINGTON RV SUPER CENTER, INC.

966 Quaker Lane  
East Greenwich, RI 02818  
(401)884-7550 Fax (401)885-4566



## SOUTH CAROLINA

CAROLINA RV SALES, INC.  
3590 Savannah Highway  
Johns Island, SC 29455  
(843)556-3449 Fax (843)402-9462

TONY'S RV PARTS & SERVICE INC.  
130 Pond Branch Road  
Lexington, SC 29073  
(803)894-3071 Fax (803)894-5385

## SOUTH DAKOTA

SCHAAP'S TRAVELAND INC.  
3100 W. Russell  
Sioux Falls, SD 57107  
(605)332-6241 Fax (605)332-5422

## TENNESSEE

AMERICAN RV CENTERS  
4050 N. Thomas  
Memphis, TN 38127  
(901)353-1999 Fax (901)353-1888

BENTON RV CENTER, INC.  
7264 Georgetown Rd. NW  
Cleveland, TN 37312  
(423)614-7800 Fax (423)478-2383

COACH & CAMPERS OF KNOXVILLE  
10260 Cogdill Road  
Knoxville, TN 37932  
(423)966-6135 Fax (423)671-6160

## TEXAS

ATHENS RV SALES INC.  
Route 7, Box 7285A  
Athens, TX 75751  
(903)675-9092 Fax (903)675-9332

CAMPER COACHES, INC.  
1701 S. Loop 289  
Lubbock, TX 79423  
(806)748-7274 Fax (806)748-7277

EAST TEXAS RV SALES  
Drawer J, Highway 96 South  
Kirbyville, TX 75956  
(409)423-4032 Fax (409)423-5824

HILLTOP TRAVEL TRAILERS  
850 W. Red Oak Rd., P.O. Box 723  
Red Oak, TX 75154  
(972)299-5074 Fax (972)617-7065

PROFESSIONAL SALES INC.  
1809 John McCain Rd., P.O. Box 1018  
Colleyville, TX 76034  
(817)488-9542 Fax (817)488-1523

RON HOOVER CO. OF BOERNE INC.  
29277 Interstate Highway 10 W.  
Boerne, TX 78006  
(830)755-2252 Fax (830)755-8644

RON HOOVER CO. OF CORPUS CHRISTI INC.  
5029 Columbia Street  
Corpus Christi, TX 78416  
(512)854-5383 Fax (512)851-9578

RON HOOVER CO. OF HOUSTON INC.  
5715 N. Freeway (I-45)  
Houston, TX 77076-4504  
(713)695-2244 Fax (713)695-2288

RON HOOVER CO. OF ROCKPORT INC.  
1510 W. Market Street, P.O. Box 747  
Rockport, TX 78382  
(512)729-9695 Fax (512)729-9698

VOGT MOTOR HOMES  
5624 Airport Freeway  
Fort Worth, TX 76117  
(817)831-4222 Fax (817)838-5574

## UTAH

JENSEN BLAINE & SONS RV CENTERS  
780 North 900 West  
Kaysville, UT 84037  
(801)544-4298 Fax (801)544-3685

## VERMONT

PETE'S RV CENTER  
4016 Williston Road  
S. Burlington, VT 05403  
(802)864-9350 Fax (802)862-4806

## VIRGINIA

CAMP-A-RAMA INC.  
1107 N. George Washington Hwy.  
Chesapeake, VA 23323  
(757)487-8113 Fax (757)485-2736

KOOGLER SALES & SERVICE, INC.  
Route 2, Box 193  
Fishersville, VA 22939  
(540)942-5556 Fax (540)943-0853

RAINBOW ACRES CAMPING RESORT INC.  
Route 2, Box 16  
King & Queen Courthouse, VA 23085  
(804)785-9441 Fax (804)785-2608

## WASHINGTON

FAMILY FUN RV  
6722 Pacific Hwy. East  
Tacoma, WA 98424-1541  
(253)472-5040 Fax (253)926-6375

THE MILESTONE RV CENTER  
6722 East Sprague Ave.  
Spokane, WA 99212  
(509)924-6446 Fax (509)891-4131

RUSS DEAN FORD INC.  
dba RUSS DEAN'S AUTOMOTIVE FAMILY  
1225 N. 32nd Place  
Pasco, WA 99301  
(509)545-9500 Fax (509)545-8229

## WEST VIRGINIA

BRAND TRAILER SALES  
2045 Fairmont Avenue  
Fairmont, WV 26554  
(304)366-7104 Fax (304)363-9345

SETZER'S WORLD OF CAMPING  
5840 Davis Creek Road  
Barboursville, WV 25504  
(304)736-5287 Fax (304)736-5992

## WISCONSIN

FINNEGAN'S RV  
205 Park Avenue  
Beloit, WI 53511  
(608)365-2306 Fax (608)365-3569

HORN'S SALES & SERVICE INC.  
8120 S. Frontage Rd.  
Sheboygan, WI 53081  
(920)564-2381 Fax (920)564-2385

## ALBERTA

MAJESTIC RV WORLD  
Woody Paylor Enterprises Ltd.  
2777 Surridge Blvd. N.E.  
Calgary, AB T1Y 3R2  
(403)291-1203 Fax (403)291-9561

VELLNER LEISURE PRODUCTS LTD.  
1890 - 49 Ave.  
Red Deer, AB T4R 2N7  
(403)343-1464 Fax (403)340-8135

## BRITISH COLUMBIA

MIDTOWN RV LTD.  
64 Industrial Avenue W.  
Penticton, BC V2A 6M2  
(250)492-5705 Fax (250)492-0430

TRAVELAND LEISURE VEHICLES LTD.  
20529 Langley Bypass  
Langley, BC V3A 5E8  
(604)530-8141 Fax (604)530-9576

TRIANGLE RV CENTRE LTD.  
10299 McDonald Park Rd.  
Sidney, BC V8L 5X7  
(250)656-1122 Fax (250)656-2161

## MANITOBA

WALT'S TRAILER SALES LTD.  
5195 Portage Avenue  
Headingley, MB R4M 1E1  
(204)837-8388 Fax (204)831-8674

## NEW BRUNSWICK

CAMPERS ALLEY LTD.  
11 Rue Bourque, P.O. Box 929  
Bouchouche, NB E0A 1G0  
(506)743-8404 Fax (506)743-8495

## ONTARIO

FRONTIER RV  
4131 Hwy. 115/35  
Orono, ON L0B 1M0  
(800)983-7878 Fax (905)983-5746

WILLIAM PATTERSON RV SALES LTD.  
R.R. # 1  
Dutton, ON N0L 1J0  
(519)762-2125 Fax (519)762-3386

## QUEBEC

RAYMOND LE BLANC INC.  
1275 Des Laurentides Boulevard  
Vimont Laval, PQ H7M 2Y2  
(514)663-7941 Fax (514)663-2213

## SASKATCHEWAN

DJS RV CENTRE LTD.  
Thatcher Dr. E. & #1 Hwy., P.O. Box 308  
Moose Jaw, SK S6H 4N9  
(306)694-6048 Fax (306)694-1221

# CHAPTER 2

## TOWING AND SAFETY PRECAUTIONS

### *Table of Contents*

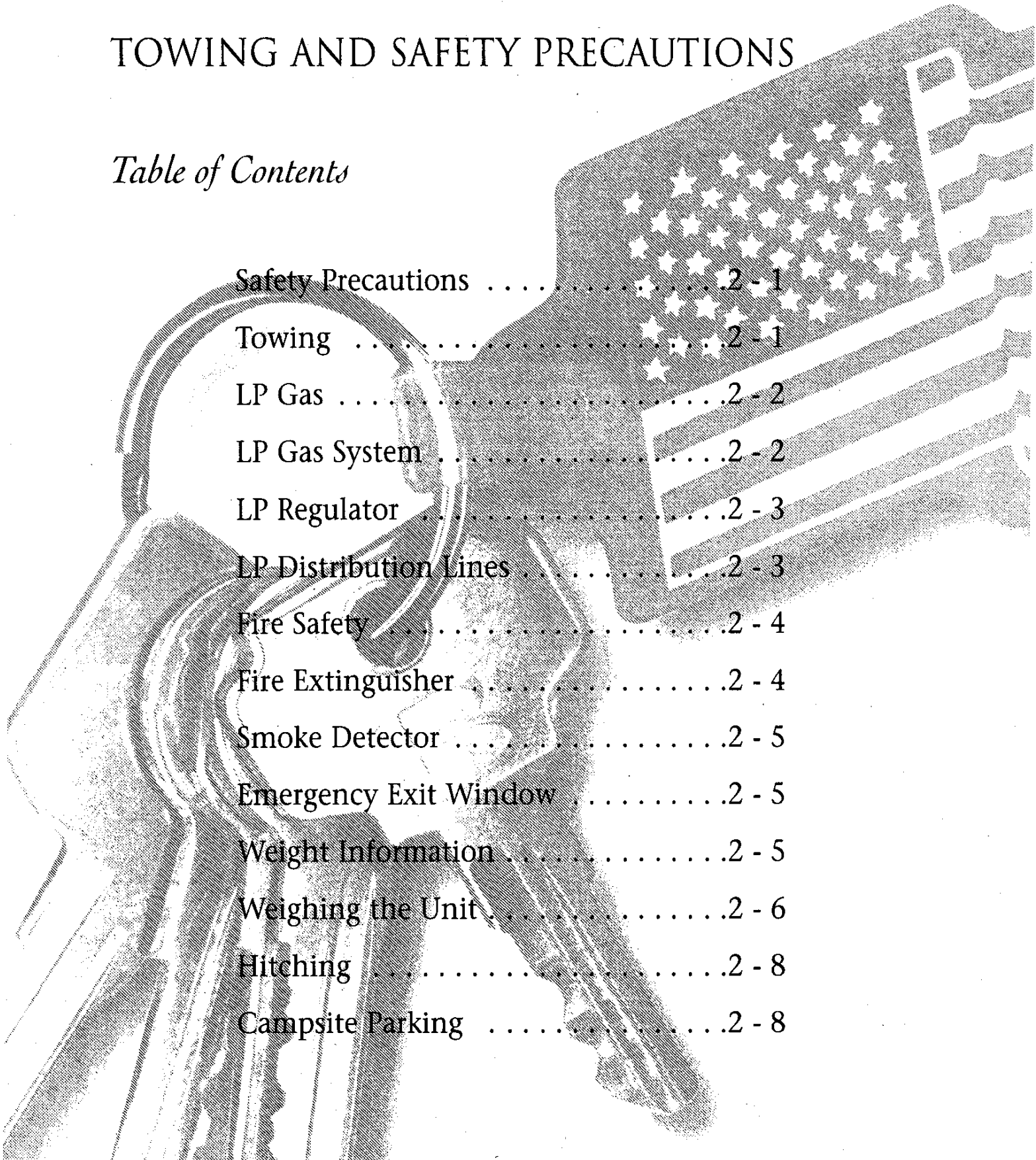

Safety Precautions .....	2 - 1
Towing .....	2 - 1
LP Gas .....	2 - 2
LP Gas System .....	2 - 2
LP Regulator .....	2 - 3
LP Distribution Lines .....	2 - 3
Fire Safety .....	2 - 4
Fire Extinguisher .....	2 - 4
Smoke Detector .....	2 - 5
Emergency Exit Window .....	2 - 5
Weight Information .....	2 - 5
Weighing the Unit .....	2 - 6
Hitching .....	2 - 8
Campsite Parking .....	2 - 8

# SAFETY PRECAUTIONS

## WARNING

Prior to towing your vehicle, be sure you have read this entire owner's guide and that you understand your vehicle's equipment completely and how to use the equipment safely.

Read and understand all of the instructions and precautions in this owner's guide before towing your new fifth wheel. Listed below are some safety precautions that must be adhered to while your vehicle is in motion. These precautions, as well as others that involve possible damage to equipment, are also listed in the appropriate areas in this manual.

## *General Warning*

### WARNING

Portable fuel-burning equipment, including wood and charcoal grills and stoves, shall not be used inside the recreational vehicle. The use of this equipment inside the recreational vehicle may cause fires or asphyxiation.

- The fire extinguisher should be inspected monthly for proper charge and operating condition. The smoke alarm should also be tested on a regular basis. In addition to the recommended inspection, these should also be checked prior to a vacation or extended trip.
- Any part of this vehicle, including the sleeping facilities, must not be used while the vehicle is in motion. It is not safe to ride in a towed vehicle and in most states it is illegal.
- Become familiar with the operation of the escape window, but use this window strictly as an emergency exit.

## *Towing*

- While driving on slippery surfaces, use care when accelerating or decelerating. Skidding and loss of vehicle control may be the result of abrupt changes in speed.
- Driving through water deep enough to wet the brakes may affect the stopping distance or cause the vehicle to pull to one side. If you have driven through deep water, check the brake operation in a safe area to be sure they have not been affected. Never operate a vehicle if a difference in braking efficiency is noticeable.
- Extreme terrain and adverse weather may affect the handling and/or performance of your vehicle.

## LP Gas

### WARNING

LP gas containers, gasoline or other flammable liquids shall not be placed or stored inside the vehicle because fire or explosion may result. LP gas containers are equipped with safety valves that relieve excessive pressure by discharging gas into the atmosphere.

- While the LP tanks must be removed before refilling, it is recommended that all pilot lights are extinguished and appliances turned off. Smoking is also prohibited at this time.
- Exhaust gases, which contain carbon monoxide (an odorless, colorless, and poisonous gas) are produced by burned gasoline, diesel or LP gas in items such as the range, tow vehicle engine, generator engine, refrigerator, furnace, and water heater. These fumes should not be inhaled.
- An open flame is never to be used to test for LP gas leaks. All protective covers and caps must be replaced after filling the LP system. Once the LP valve is closed, securely latch the LP door.
- LP gas and natural gas are not interchangeable. Never connect natural gas to the LP gas system.
- The use of equipment such as wood and charcoal grills and stoves inside this recreational vehicle may cause fires or asphyxiation.

## LP GAS SYSTEM

### *General Information*

A warning label has been located near the LP gas container. This label reads:

### WARNING

DO NOT FILL CONTAINER(S) TO MORE THAN 80 PERCENT OF CAPACITY.

Over filling the LP gas container can result in uncontrolled gas flow, which can cause fire or explosion. A properly filled container will hold approximately 80 percent of its volume as liquid LP gas.

The LP gas system components in your unit have been approved for use in camping vehicles by a nationally recognized testing laboratory. LP gas is a clean-burning dependable fuel when properly handled. The LP gas tank(s) mounted on your unit contain liquid petroleum gas under high pressure. The liquid gas vaporizes as the fuel is used and passes through the tank valve to a regulator that automatically reduces the pressure. The low-pressure gas is then distributed to the appliances through the pipe manifold system. Appliance lighting problems are commonly caused by an improperly adjusted gas regulator. Never attempt to reset the

regulator yourself. Have an authorized service technician make any necessary adjustments. We recommend that you have the LP gas system checked by an authorized service technician at least once a year, and after every extended trip. Although the manufacturer and dealer test carefully for leakage, travel vibrations could loosen fittings. Leaks can be easily found by applying leak detector solutions at the connections. If leak detector solution is not available, a soapy water solution made with dish soap can be used. Tightening the fitting usually stops any leaks. If this does not work, shut off the main gas valve at the tank and immediately consult an authorized technician for repairs. If a leak is suspected, the identifying order smells similar to rotten eggs (sulfur). Never test for a leak by lighting a match or have an open flame where you suspect leaking gas.

### WARNING

Shut off the main gas valve at the tank when the camping vehicle is not in use. Also, shut off the valve when refueling to avoid potential danger from pilot lights igniting fuel fumes. Some appliances, such as the refrigerator, water heater, and furnace, have DSI (direct spark ignition) boards so it is important that you turn the appliances off when the LP gas is off. The ignition in the appliances will continue to spark even if there is no LP gas available.

## *LP Regulator*

The regulator acts as the heart for the LP gas system. The LP gas in the tank is under high pressure. The regulator reduces the pressure of this gas so that it is safe to use with the various appliances in your unit. If corrosion is noticed, contact a qualified LP gas service technician. Do not adjust the regulator. It is factory preset. Adjustments are to be made by a qualified LP service technician using specialized equipment.

LP gas regulators must always be installed with the diaphragm vent facing downward. Regulators that are not in compartments have been equipped with a protective cover. Make sure that the regulator vent faces downward and that the cover is kept in place to minimize the vent blockage that could result in excessive gas pressure causing fire or explosion.

## *Distribution Lines*

The primary manifold is a black steel pipe running the length of your unit. Most secondary lines leading to gas appliances are made of copper tubing with flare fittings. If any of the gas lines rupture, do not attempt to splice them. Always run a new line. We recommend gas distribution work be performed by an authorized service technician. The main valve at the LP tank must be closed when removing or servicing any gas appliance. This will prevent dangerous gas leakage that could result in an explosion and possibly serious injury. If a leak is suspected, have the systems inspected and repaired by a qualified service technician.

## *Precautions & Recommendations*

- Inspect the LP fill valve for foreign materials before refueling.
- Shut the pilot lights off prior to refueling LP gas tanks.
- Never check for gas leaks with an open flame (match, etc.).
- Gas lines should be visually inspected periodically.
- Have the gas system inspected yearly and before and after extended trips.
- The gas system should be inspected and repaired by qualified technicians only.

### WARNING

The LP system in your recreational vehicle is designed for liquefied petroleum gas only. Never attempt to connect natural gas or butane gas in this system.

## FIRE SAFETY

The possibility of fire exists in all areas of life, and the recreational life-style is no exception. Recreational vehicles are complex machines. They are made up of many materials, some of which are flammable. Like most hazards, the possibility of fire can be minimized, if not totally eliminated. This is done by recognizing the danger and practicing common sense safety and maintenance habits. For safety reasons, your unit is furnished with both a fire extinguisher and a smoke alarm.

### *Fire Extinguisher*

The fire extinguisher is rated for Class B (grease, gasoline, diesel fuel, flammable liquids) and Class C (electrical) fires. These are the most common types of fires in vehicles. Read the operator's manual and the instructions on the fire extinguisher. Be sure to know how and when to use the extinguisher and where it is located.

Fire extinguishers are mechanical, pressurized devices. Care must be exercised when they are handled. They must be maintained as the operator's manual instructs for proper and safe operation. The extinguisher should be inspected at least once a month. More frequent inspections may be required if the extinguisher is exposed to the weather or to possible tampering. Do not test the extinguisher by partially discharging. Doing this will cause a loss of pressure.

If a fire occurs in the vehicle, evacuate the vehicle as quickly and as safely as possible. Consider the cause and the severity of the fire and the risk involved before trying to extinguish it. If the fire is major or fuel fed, move away from and stand clear of the vehicle and wait for emergency assistance to arrive.

## Smoke Detector

The battery powered smoke detector is mounted on the ceiling in the living area of the unit. Read the operating instructions for details on the testing and care for this important safety device. Test the smoke detector after the unit has been in storage, before each trip, and at least once a week during use. The detector should never be disabled because of nuisance or false alarm from cooking smoke or a dusty furnace. Ventilate the unit with fresh air and the alarm will shut off. Never disconnect or remove the battery from the smoke alarm. The battery should be replaced once a year or when the low battery signal sounds.

## Emergency Exit Window

In the bedroom or slide out of the unit, there may be an emergency exit (egress) window. This window is designed to be used as an additional exit in emergency situations. It can be easily identified by the red handle and the red "EXIT" label. To open the egress window, lift the handle and push outward on the window. The window can be closed by pulling the window shut and lowering the handle in the down or locked position.

## WEIGHT INFORMATION

Below is a sample of a weight information label which may appear in your unit.

TOWABLE WEIGHT INFORMATION	
Newmar Unit Number _____	<b>SAMPLE</b>
Model _____	
GVWR _____	
UVW _____	
NCC _____	
<b>GVWR</b> (Gross Vehicle Weight Rating) means the maximum permissible weight of this trailer. The GVWR is equal to or greater than the sum of the Unloaded Vehicle Weight plus the Net Carrying Capacity.	
<b>UVW</b> (Dry or Unloaded Vehicle Weight) means the weight of this trailer as built at the factory. If applicable, it includes full generator fuel, engine oil, and coolants. The UVW does not include cargo, fresh water, LP gas, or dealer installed accessories.	
<b>NCC</b> (Net Carrying Capacity) means the maximum weight of all personal belongings, food, fresh water, LP gas, tools, dealer installed accessories, etc., that can be carried by this trailer. (NCC is equal to or less than GVWR minus UVW)	
This trailer is capable of carrying up to _____ gallons of fresh water (including water heater) for a total of _____ pounds. Reference: Weight of fresh water is 8.33 lbs/gal, Weight of LP gas is 4.5 lbs/gal (average).	
<b>CONSULT OWNER'S MANUAL FOR SPECIFIC WEIGHING INSTRUCTIONS AND TOWING GUIDELINES.</b>	

## *Weighing the Unit*

The following definitions are given to help in communications of issues of weight and your unit.

- GAWR: Gross Axle Weight Rating means the maximum permissible weight for an axle. This takes into consideration the weakest link in the tire, wheel, brakes, hubs, axle, springs, and attaching parts. For example, if the axle is rated at 6,000 pounds and the tires are rated at 2,540 pounds each, the maximum GAWR would be 5,080 pounds.
- GVWR: Gross Vehicle Weight Rating means the maximum permissible weight of this trailer. The GVWR is equal to or greater than the sum of the Unloaded Vehicle Weight plus the Net Carrying Capacity.
- UVW: Unloaded Vehicle Weight means the weight of the trailer as built at the factory. If applicable, it includes full generator fuel, engine oil, and coolants. The UVW does not include cargo, fresh water, LP gas, or dealer installed accessories.
- NCC: Net Carrying Capacity means the maximum weight of all personal belongings, food, fresh water, waste water, LP gas, tools, dealer installed accessories, etc., that can be carried by the trailer. NCC is equal to or less than the GVWR minus the UVW.
- GVW: Gross Vehicle Weight is the weight of the unit with all items and supplies that are loaded into the unit at any point in time.

To assure the accuracy of your weights be sure the unit is always level during weighing.

The unit has been built to comply with the component suppliers recommended limits and give you a realistic NCC. When loading the unit, distribute the items so that not all of the weight is added to one area of the unit. If you have questions as to what the weight of the unit is after it has been loaded, take the unit to a drive on scale, or use individual wheel scales and verify that the weights are within the limits of those specified for the unit. When weighing the unit follow these instructions. Failure to follow these instructions may give an erroneous weight reading.

## *Notes*

---

---

---

---

---

---

---

---

---

---



# Fifth Wheels

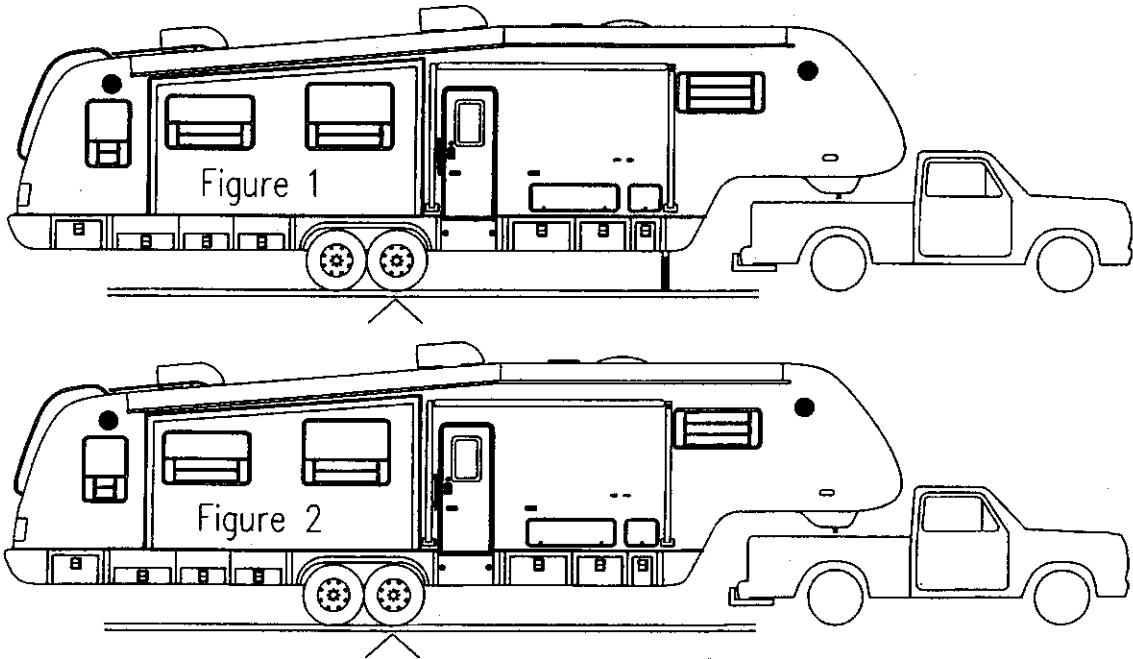

1. Pull the unit onto the scales shown in Fig. 1. This is the total weight of the unit. To do this, put the front jacks down far enough to take all of the weight off of the tow vehicle and onto the scales. Make sure that only the trailer is on the scales. Record the weight. This is the GVW and should not exceed the GVWR supplied by Newmar for the unit.
2. Hook up to the unit and be sure, again, that there is no part of the tow vehicle on the scales as shown in Fig. 2. Weigh the unit with only the trailer tires on the scales. Record the weight. This is the total weight on the axles. When this amount is subtracted from the GVW (first reading), the difference is the hitch weight. To achieve the approximate weight on each axle, divide the weight from Fig. 2 by the number of axles. This amount should not exceed the GAWR of the unit. For example 9,360 pounds with 2 axles is 4,680 pounds per axle or approximately 2,340 pounds per tire.

## Notes

---

---

---

---

---

---

---

---

# Hitching

## IMPORTANT:

Your fifth wheel is equipped with electric trailer brakes. Make sure the proper brake controls are installed and in working order before traveling.

Hooking the fifth wheel will become quite simple after a little practice. Follow the steps listed below.

1. Adjust the fifth wheel jacks until the trailer is at the height level for hooking to the tow vehicle.
2. Place wheel chocks behind the wheels of the coach.
3. Release the fifth wheel lock handle.
4. Align the tow vehicle so the fifth wheel will accept the kingpin.
5. Back the tow vehicle slowly into the fifth wheel until the kingpin engages in the fifth wheel lock, automatically locking.
6. Verify that the lock is closed.
7. Connect the electrical pigtail between the fifth wheel and the tow vehicle.
8. Connect the break away switch line. Be sure the break away switch cable is not attached to any part of the tow vehicle hitch assembly. Make sure there is enough slack in the break-a-way cable to allow for turning.
9. Adjust the mirrors on the tow vehicle.
10. Check all of the lights on the fifth wheel and the tow vehicle (running lights, brake and tail lights, turn signal lights, and back up lights).
11. Pick up and store the wheel chocks.
12. Check the inside of the coach to verify that everything is stored properly, vents are closed, all of the doors and drawers are shut, and the TV antenna lowered. Close the entrance door and retract the steps.
13. Raise the fifth wheel jacks so the entire hitch load is on the tow vehicle. The jacks should be about 2" off of the ground. Do not raise the jacks completely until you have tested the brake control. This will also test the hook-up.
14. Pull the unit forward and apply the hand control for the trailer brakes to be sure they are operating properly.
15. Completely raise the fifth wheel jacks.

## Campsite Parking

If the campground does not have drive through sites, it is recommended to stop near the site and inspect it for slopes or uneven areas. Back into the site carefully. Watch for low-hanging limbs, posts, large rocks or other obstacles. Back in so the site is on the driver's left. This will enable the driver to watch the rear of the unit. Maneuver the vehicle into position before backing into the site. Back up slowly, using the side mirrors as a guide or with the assistance of another person outside, guiding the parking procedure.



# CHAPTER 3

## AIR CONDITIONING & HEATING

### *Table of Contents*

Air Conditioning .....	3 - 1
Furnace .....	3 - 2
LP Bottles .....	3 - 3
LP Bottle Filling .....	3 - 3
LP Regulator .....	3 - 4
LP Detector .....	3 - 4

# AIR CONDITIONER(S)

The roof mounted central air conditioner installed on your unit will operate only when the unit is supplied with 120 volt AC power from the power cord or the optional generator. The air conditioner circuit breaker must be in the "ON" position to work. The air conditioner installed on this unit is equipped with an electric heat strip. This is used to take the chill off the unit or any time a little warmth is needed. Depending upon which option package was installed, the unit may be equipped with two air conditioners.

Park the vehicle in the shade with the drapes or blinds closed for the best performance. Set the thermostat to the desired temperature while keeping the doors and windows closed. Keep in mind that air conditioners use a large portion of the available electric power.

RV parks may experience low voltage on days with high heat or humidity. This is commonly referred to as a "brown out". A brown out may trip the air conditioner circuit breaker. The circuit breaker protects your air conditioner motor from damage and is necessary during low voltage conditions. The tripping breaker is not a fault in your electrical system.

The cool air from the air conditioner is ducted throughout the coach through the cool air ceiling ducts. Warm air is returned to the air conditioner through return air ceiling ducts. Below is the thermostat that controls the air conditioner. It also controls the furnace. Simply select the desired temperature. The blower will cycle automatically, or you may choose low, medium or high fan settings.

**Step One:** Move power switch to ON

**Step Two:** Press MODE button to select function. (COOL\*, FURNACE, FAN ONLY, etc.)

\* There is an approximate 2-minute time delay after selecting cooling function for refrigerant compressor to start.

**Step Three:** Press FAN button to select fan speed or automatic operation.

**Step Four:** Press UP or DN button to set your desired temperature for the zone.

**Step Five:** If your vehicle contains more than one zone, depress FAN and MODE simultaneously to select zone 2, and repeat procedures from step 2 above. Repeat entire procedure for each additional zone.

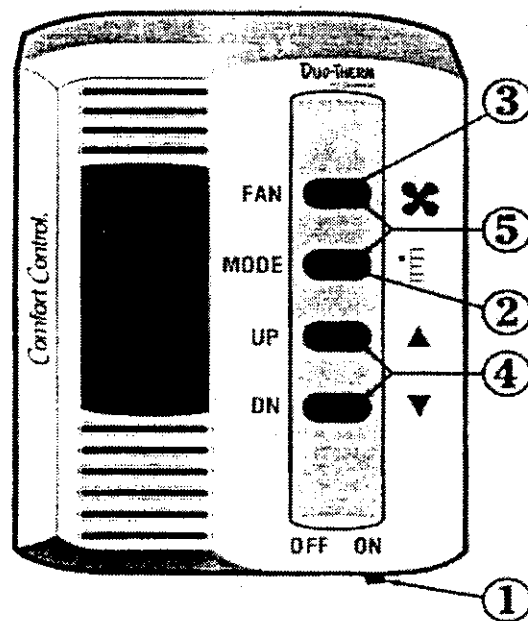

**Shutdown:** If you turn the Comfort Control off, or if there is a power interruption for any reason, the system will resume operation on the last settings when power returns.

# FURNACE

## WARNING

Never attempt to modify this furnace. Fire, explosion, asphyxiation, or carbon monoxide poisoning may occur. If the furnace malfunctions, consult a trained service technician.

The furnaces installed in your unit are forced-air furnaces fueled by LP gas. Your unit is equipped with two furnaces. The living area furnace is controlled by the air conditioner wall thermostat that controls the heating, and cooling of the unit. The furnace installed in the bath/bedroom area is controlled by the thermostat in the bedroom.

The heat is supplied to the unit through ducts in the floor. The furnace will not operate properly if the air flow at the floor registers, or the air return to the furnace, is blocked by personal or storage items. Storage under the cabinets should be done carefully to prevent crushing or damaging the furnace ducting or blocking of the warm air return.

Smoke and fumes may be created as a result of the residual burn off of the manufacturing compounds that are sometimes present the first time the furnace is used. This is normal. To minimize the smoke and fumes, the initial lighting of the furnace should be done with the windows and doors open. Continue until the residue is completely burned off.

To operate, set the thermostat to the desired temperature setting and turn the thermostat to the on position. Allow 60 seconds for the furnace to begin operating. To shut down the furnace, turn the thermostat to the off position. After the furnace has been turned off, the fan will run for approximately 60 seconds to cool down.

For your safety, do not use gasoline or other flammable liquids in the vicinity of the furnace or any other appliance. Clean the complete furnace and air tube passageways periodically to remove dust, lint, etc. Check the gas system for leaks at least once a year. Check and clean the blower wheel annually.

On the exterior of the coach you will find a furnace cover. There are no owner serviceable parts on the furnace. This cover should be removed by authorized service technicians only.

## WARNING

Use caution when washing the exterior of your vehicle. Water should not be sprayed directly into the furnace vent. If water is forced beyond the rain baffles into the furnace vent, rusting of the furnace could occur. This could also cause improper combustion.

The furnace should be thoroughly cleaned before the start of each heating season. Any debris in the system may restrict air flow for combustion, bind the combustion air impeller, or prevent the blower motor from running properly. Also, check the burner pilot orifices for debris. Lint accumulations may cause the blower to become unbalanced, vibrate, restrict the ability of the blower to move air. If lint is blown into the heat exchanger, it may cause odors or create a fire hazard. Contact an authorized service technician for annual cleaning. Consult the manufacturer's operating instructions in your Owner's Package for further information.

## WARNING

Portable fuel burning appliances are not safe for heating inside the recreational vehicle. Asphyxiation or carbon monoxide poisoning can occur.

## LP BOTTLES

This unit is equipped with two 30# LP bottles. These bottles are controlled with an automatic pressure regulator. The LP bottles contain liquid petroleum gas under high pressure. As the fuel is used, the liquid gas vaporizes and passes through the tank valve to a regulator that automatically reduces the pressure. The low-pressure gas is then distributed to the appliances throughout the pipe manifold system. Improperly adjusted regulators are the major cause of appliance lighting problems. Never attempt to reset the regulator. This is to be done by a qualified service technician. While in high altitudes or extreme cold weather a gas shortage may be experienced. Using one appliance at a time can help adjust to this problem.

It is recommended to have the LP system inspected by an authorized service technician at least once a year and after every extended trip. This system is tested by both the manufacturer and the dealer. Leaks can be caused by travel vibrations, therefore routine inspections are recommended.

The primary gas manifold is a black steel pipe running the length of the unit. All secondary lines leading to the gas appliances are made of copper tubing with flare fittings. If any of these lines rupture do not attempt to splice them. Always have a new line ran. Gas distribution work must be performed by an authorized service technician. When removing or servicing any gas appliance, close the main gas valve at the LP bottles. This will prevent dangerous gas leakage that could result in an explosion and possible serious injury. If a gas leak is suspected, have the system inspected and repaired by a qualified service technician as soon as possible.

## WARNING

The main gas valve must be shut when the vehicle is not in use. Shut the valve off when refueling to avoid potential danger from pilots lights igniting fuel fumes. Gas valves on appliances with direct spark ignition (DSI) should also be in the off position. Do not store LP, gasoline, diesel, or other flammable liquids inside the vehicle. Fire or an explosion could be the result of ignoring this warning.

## *LP Bottle Filling*

Do not fill the bottles to more than 80 percent of capacity. Fire or explosion may be the result of uncontrolled gas flow from an overfilled tank.

## *LP Regulator*

The regulator is the heart of the LP system. The regulator reduces the pressure of the gas so it is safe to use with various appliances. Regulators are equipped with a vent. In the event excess pressure builds up in the body of the regulator, a relief mechanism vents it to the atmosphere. It will vent until the pressure returns to the normal range. The vent must be kept clean and clear of obstructions or corrosion. A clogged vent could cause the failure of components. Contact a qualified LP technician if corrosion or obstruction is noticed.

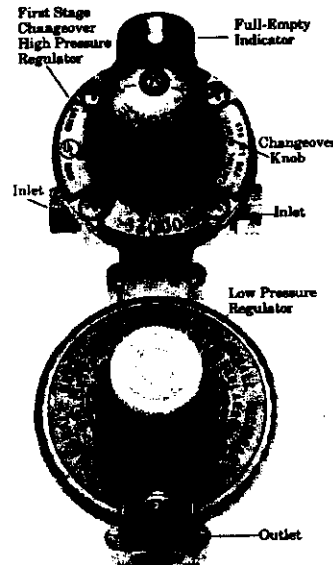

The presence of moisture in LP fuel causes the regulators to freeze. The moisture will pass through the cylinder valve and into the regulator where freezing occurs. To help prevent the regulator from freezing, always keep the tank control valve closed when not in use, even when the tank is empty, to prevent moisture from collecting on the inside.

If moisture becomes a problem, consult an authorized LP service center for assistance.

## *LP Gas Detector*

### WARNING

Never check gas lines for leaks with an open flame. Do not check for leaks using ammoniated or chlorinated household type detergents. These detergents can cause cracks to form on the metal tubing and brass fittings. Take the unit to a qualified LP gas service technician to find and repair the leak. Keep the tank valve closed and all of the appliances turned off when the unit is stored. If any of the LP gas valves do not close leak-tight by hand, consult a service technician.

Liquid Propane (LP) Gas is heavier than air and will settle to the lowest point of the room, which is generally on the floor of your coach. Because of this, the LP detector installed in your coach is located near the floor. The detector is also sensitive to other fumes, such as hair spray, which contain butane as the propellant. Butane, like propane, is heavier than air and will settle to the floor level where it may be detected. When this occurs, press the reset button to stop the alert sound for 60 seconds.





# CHAPTER 4

## APPLIANCES & ACCESSORIES

### *Table of Contents*

Refrigerator . . . . .	4 - 1
Microwave . . . . .	4 - 2
Range Hood . . . . .	4 - 2
Range . . . . .	4 - 2
Television Antenna . . . . .	4 - 3
Television . . . . .	4 - 4
Cable & Telephone Jack . . . . .	4 - 4
Video Control Center . . . . .	4 - 5
Video Cassette Recorder . . . . .	4 - 6
Stereo . . . . .	4 - 6
Water Heater . . . . .	4 - 6
Water Heater Storage . . . . .	4 - 7
Water Heater Relief Valve . . . . .	4 - 7
Washer/Dryer . . . . .	4 - 7
Ceiling Fan . . . . .	4 - 8

# MAJOR APPLIANCES

## Refrigerator

Before starting the refrigerator, verify that the main LP gas valve is in the on position. The refrigerator is equipped with a semi-automatic energy selector (AES) control system. It can be set to select either 120 volt or LP gas operation, automatically, if desired.

### WARNING

Most LP gas appliances used in recreational vehicles are vented to the outside of the vehicle. When parked close to a gasoline pump it is possible that the gasoline fumes could enter this type of appliance and ignite the burner flame causing a fire or explosion. Use caution when refueling.

A 12 volt power supply must be available for the electronic control panel to function. The shore line must be plugged in, or the optional generator running, to operate in the 120 volt mode. The main LP gas valve must be open for operation in the LP mode. To start the refrigerator, press the main power ON/Off button to the ON position.

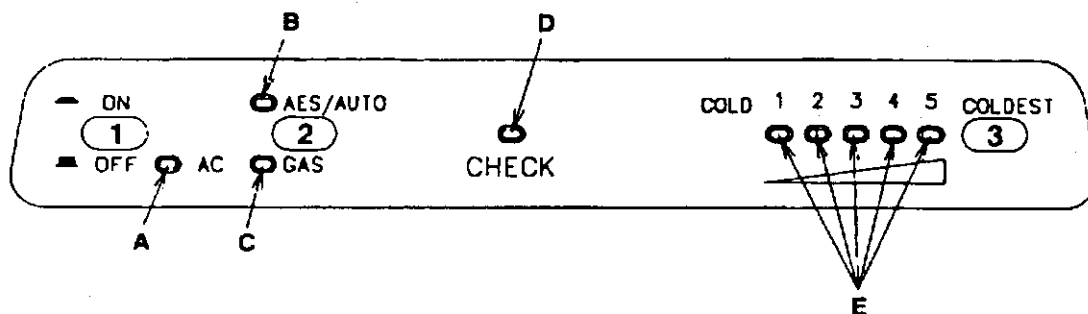

#### LEGEND 2-WAY AES Model

1. Main Power Button ON/OFF
2. AES/AUTO/GAS Mode Selector Button
3. Temperature Selector Button

- A. AC Mode Indicator Lamp
- B. AES/AUTO Mode Indicator Lamp
- C. GAS Mode Indicator Lamp
- D. CHECK Indicator Lamp
- E. Temperature Indicator Lamps

To use the 2-way Auto Mode, push the AUTO/GAS mode selector into the ON position. If 120 volt is available, the AC mode indicator light will be illuminated designating AC operation. If 120 volt is not available, the gas mode indicator light will be illuminated. The control system will automatically switch to gas operation. To operate on gas only, push the AUTO/GAS mode selector until the gas indicator light has lit. After 45 seconds, the burner should be ignited and operating normally. The initial start up may take longer than 45 seconds in order to allow the air to be purged from the gas line. If the gas does not ignite within 45 seconds, the check indicator light will illuminate and the gas mode light will go off. If the check indicator light illuminates and the gas mode indicator light is off, then the controls have failed to ignite the burner in the gas mode. When the check indicator light is on, press the main power ON/OFF button to the off position to reset. Do not continue to reset the gas operation if the check indicator light continues to illuminate after several tries.

The thermostat on the refrigerator controls the gas and electric operation. This eliminates the necessity of resetting the temperature each time a different energy source is used. Press the temperature selector button until the light at the desired setting is illuminated. After the initial start up, the thermostat should be moved from the coldest setting to the desired setting, which is usually mid range.

An optional feature on the Dometic refrigerator is the addition of an automatic ice maker in the freezer compartment. For detailed operating instructions, please consult the manufacturer Owner's Manual in the Owner's Package.

## *Microwave*

The microwave installed in you unit is a convection microwave. All microwaves operate off of 120 volt electricity. The microwave's control panel is the touch pad type. Simply enter the temperature, mode, and cooking time desired. The microwave is plugged into the electrical outlet through a surge protector. This will help protect the microwave in case of an electrical surge. For instructions on how to operate any of the special features on the microwave oven, please refer to the microwave Owner's Manual in your Owner's Package.

## *Range Hood*

The range hood is incorporated into the microwave. The microwave control panel operates the range hood functions. This range hood has both a fan and a light for your convenience. The fan has two speeds, low, and high. Simply select the desired setting from the microwave control touch panel. For further detailed information on the hood operation, refer to the microwave Owner's Manual .

## *Range*

The range installed in this unit is a three-burner range top. The burners on the range top are not equipped with a pilot light. They are controlled by an automatic spark ignition. Depressing the knob automatically starts the electronic spark ignitors. To light the burner, press down and turn the respective knob counter-clockwise to the ignite position. Continue to press down on the knob for about ten seconds to engage the safety mechanism. Release the knob. The burner should remain lit. If not, repeat the procedure, depressing the knob for a slightly longer time. Once lit, release the knob and set to the desired setting. To turn the burner off, turn the knob clockwise towards the "off" position.

For further instructions, refer to the oven manufacturer's Owner's Manual in your Owner's Package.

### **WARNING**

It is not safe to use cooking appliances for comfort heating. Cooking appliances need fresh air for safe operation. Before operation:

1. Open overhead vent or turn on an exhaust fan.
2. Open a window.

Unlike homes, the amount of oxygen supply is limited due to the size of the recreational vehicle. Proper ventilation when using the cooking appliance(s) will avoid dangers of asphyxiation. It is especially important that cooking appliances not be used for comfort heating as the danger of asphyxiation is greater when the appliance is used for long periods of time.

The following label has been placed in the vehicle near the range area:

### *If You Smell Gas:*

1. Extinguish any open flames, pilot lights, and all smoking materials.
2. Do not touch electrical switches.
3. Shut off the gas supply at the tank valve(s) or gas supply connection.
4. Open doors and other ventilating openings.
5. Leave the area until the odor clears.
6. Have the gas system checked and leakage source corrected before using again.

## TELEVISION OPERATION

### *Winegard Television Antenna*

The TV antenna in your unit is designed for reception of all color and black-and-white channels. If the reception is poor, you should verify that the power switch is in the "ON" position and that all of the connectors are tight. If poor reception still occurs, consult your authorized dealer.

To raise the antenna into the operating position, turn the elevating crank (clockwise) in the "UP" direction, about 13 turns, or until some resistance to turning is noticed. On the power booster, turn the switch to "ON" in order to amplify the signal being received. Once in the "UP" position, rotate the antenna to receive the best picture. This is done by pulling down on the directional handle with both hands until it disengages from the ceiling plate and then rotating it until reception has improved. The antenna must be lowered before moving the vehicle. To lower, rotate the directional handle until the pointer is aligned with the pointer on the ceiling plate. Turn the elevating crank (counter-clockwise) in the "DOWN" direction, about 13 turns, or until some resistance to turning is noticed. The antenna is now locked and in the travel position.

RAISING ANTENNA TO OPERATING POSITION

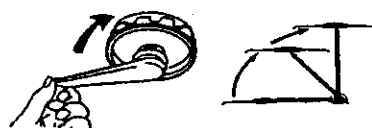

ROTATING ANTENNA FOR BEST PICTURE



LOWERING ANTENNA TO TRAVEL POSITION

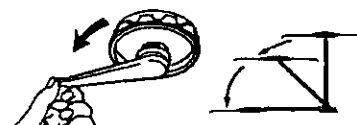

#### CAUTION

Under no circumstances should you lower the antenna in any position except the travel position.



## Video Control Center (Optional)

The Audio Video Control Center will direct the signal being received by up to two televisions and one VCR. Simply push a button to select what is viewed and where. To control what is being viewed on the front television use the selections for "TV 1." To control what is being viewed on the bedroom (and outside television, if installed) use the selections for "TV 2." Each television is capable of viewing different programming at the same time. For example,

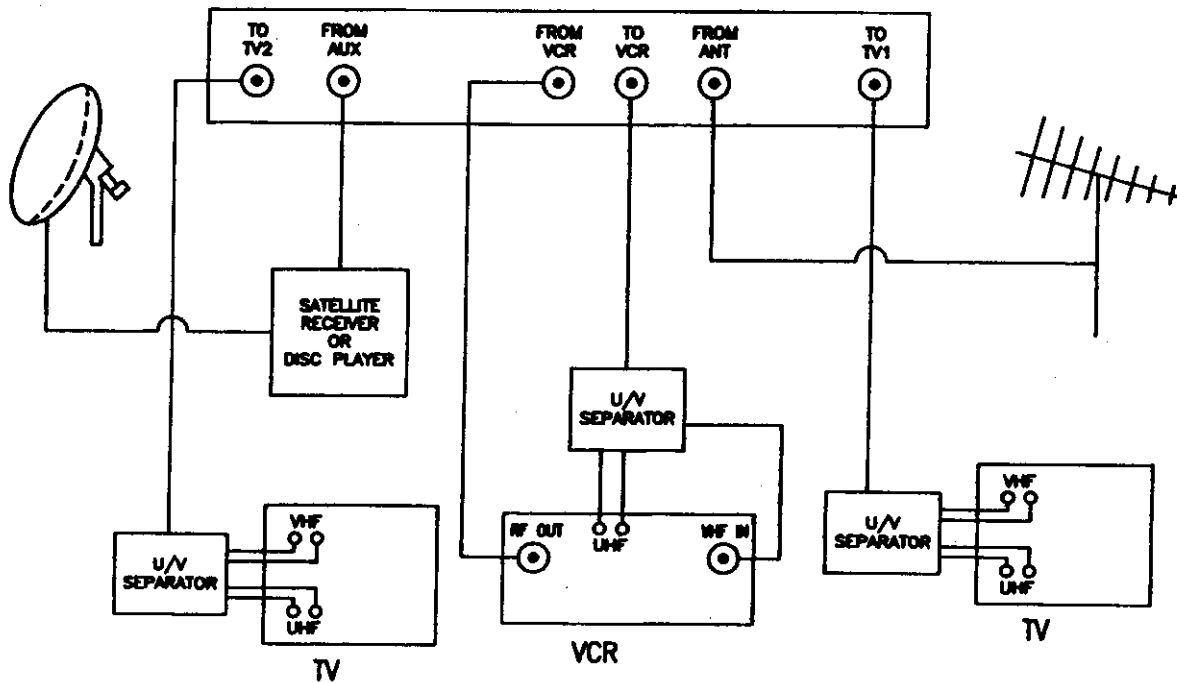

by selecting "ANT" for "TV 1" you are able to watch your favorite network broadcast on the front television, while a movie from the VCR is being watched in the bedroom or outside, after selecting the "VCR" button for "TV 2." This control center is capable of receiving three sources of input. They are "FROM ANTENNA," "FROM VCR," and "FROM AUX." The "FROM AUX" selection is used for cable input. It will also accommodate video game systems.



## *Video Cassette Recorder*

The video cassette recorder (VCR) is installed in your unit as standard equipment. It is in the living room entertainment center. The controls are on the face of the VCR and on the remote control. For more detailed information regarding the VCR functions consult the VCR Operator's Manual in the Owner's Package. The video switch will assist you in directing the VCR signal to the television of your choice.

## *Stereo*

The standard stereo installed in your unit is an AM/FM Cassette player. There are speakers located throughout the unit for listening pleasure. The operation of the stereo is similar to that of many car stereos. It operates on 12 volt electricity from the coach batteries. For further information on the operation of this stereo, consult the stereo Owner's Manual in the Owner's Package.

## WATER HEATER

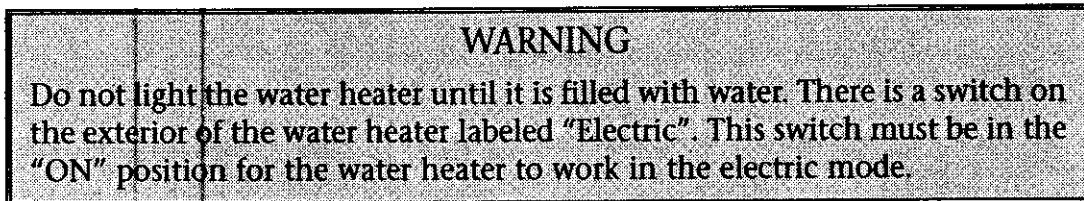

Before lighting the water heater fill the fresh water system. Purge any air from the water heater by opening all hot water faucets until water flows steadily from each one. The water heater installed in this unit is a ten gallon gas/electric model with a direct spark ignition (DSI). This water heater operates on either LP gas or 120 volt electricity.

It is important to read all of the safety information provided in the water heater manufacturer Operation Manual in the Owner's Package. The following instructions are for the standard water heater with direct spark ignition (DSI).

This appliance does not have a pilot light. It is equipped with an ignition device which automatically lights the burner. Do not try to light the burner by hand. Before lighting, smell all around the appliance area for gas. Be sure to smell next to the floor because some gas is heavier than air and will settle on the floor. Consult the Operation Manual for further instructions if a gas leak is noticed. The gas valve is fully automatic, no adjustments are necessary. Read the safety information provided in the Operation Manual before lighting the appliance. Turn off all electrical power to the water heater. Turn the gas supply to the "OFF" position. Wait five minutes for the gas to clear the area. If you smell gas, STOP! Following the safety instructions in the Operations Manual. If gas odor is not noticed than turn the gas supply to the "ON" position. Turn on the electrical supply to the water heater. Inside the unit there is a switch marked "WATER HEATER". Turn the switch to the "ON" position. There will be a 15 second purge before the unit will spark. If the burner does not light on the first try, there will automatically be 2 more tries for ignition before it will lock out. Each ignition



cycle will have a 15 second purge. If lock out occurs before the main burner lights, turn the switch to "OFF", wait five seconds and turn the switch to "ON" again. This will re-start the ignition cycle. The initial start-up of the water heater may require several ignition cycles before all of the air is purged from the gas lines.

#### WARNING

Do not store any combustible materials or liquids near or adjacent to the water heater.

## *Storage*

When storing your unit for the winter months, the water heater must be drained to prevent damage from freezing. The first step is to turn off all electrical power and LP gas going to the water heater. The water pump must also be turned off. Open both the hot and cold water faucets to drain the lines. Open the drain on the water heater. Drain the entire water system. When preparing the unit for use after it has been stored, make certain the water system, including the water heater has been filled before re-lighting the water heater. Failure to fill the water heater before lighting may damage the water heater and void the warranty.

## *Pressure Relief Valve*

The temperature and pressure relief valve is designed to open if the temperature of the water within the heater reaches 210 F, or if the water pressure in the heater reaches 150 pounds. Recreational vehicle water systems are closed systems and during the water heating cycle the pressure build-up in the water system may reach 150 pounds. When this pressure is reached, the pressure relief valve will open and water will drip from the valve. This dripping will continue until the pressure is reduced to below 150 pounds, and the valve closes. This condition is normal and does not indicate a defective relief valve.

#### WARNING

Do not plug the relief valve under any circumstances.

## *Washer/Dryer (Optional)*

The plumbing and/or the installation of a washer and dryer is part of the various option packages available on your unit. The washer and dryers used by Newmar function as those in a home, operating on 120 volt electricity. For more detailed information on the operating instructions, read the appliance Owner's Manual in the Owner's Package.

#### CAUTION

The grey tank valve must be in the "open" position when operating the washing machine.



# CHAPTER 5

## CABINETS & FURNITURE

### *Table of Contents*

Cabinets .....	5 - 1
Furniture .....	5 - 2
Living Room Area .....	5 - 2
Bed Room Area .....	5 - 2

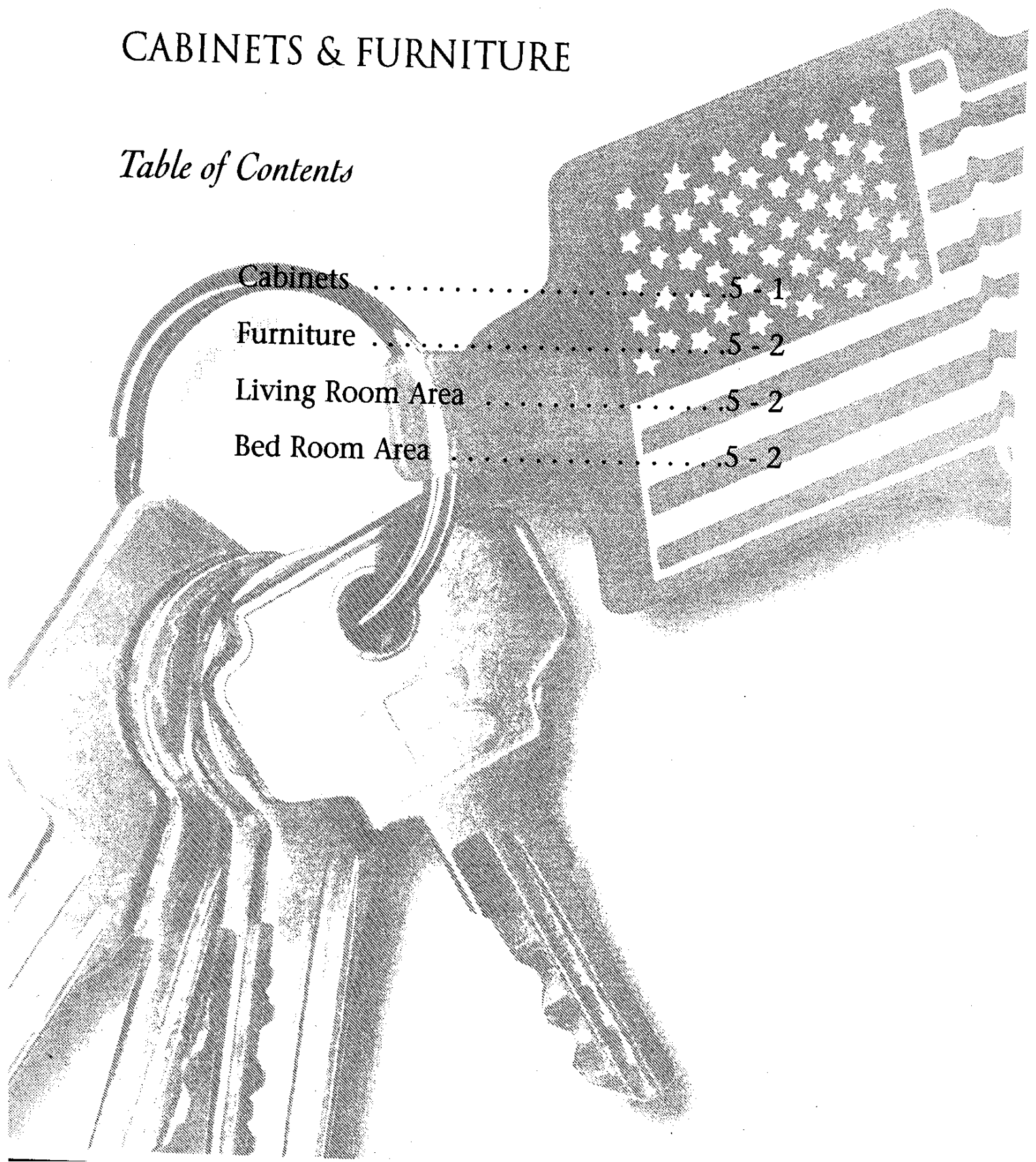

# CABINETS

The cabinets in this unit are constructed on site, at the Newmar production facility. Cherry cabinetry and cherry frame doors with cathedral style raised panels are standard throughout the unit. The two cabinetry options are oak and frosted maple. All decors have brass door and drawer pulls. These give the interior an added touch of class.

Available on some floor plans, the Corian countertop extension provides additional counter space while cooking, and folds out of the way while entertaining. Consult the manufacturer's care instructions on the Owner's Information card in the Owner's Package provided with this unit. The silverware drawer contains a molded silverware divider tray for added storage.

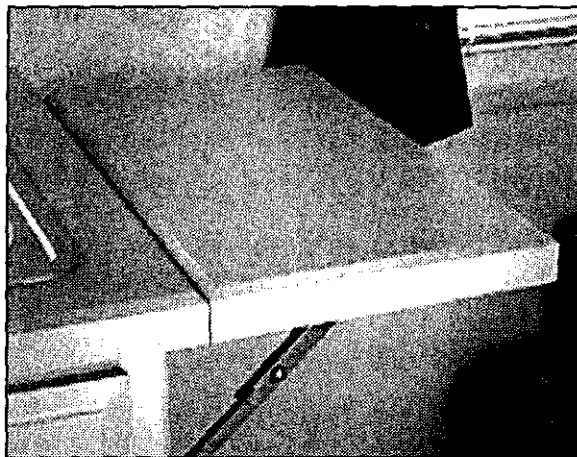

Storage is an important factor to all RV owners. Keeping this in mind, the cabinetry is structured to provide as much storage as possible. Some models have pantry style cabinets in the kitchen for added storage. In the bedroom on all models, the bed platform lifts for convenient storage. This platform is held open by gas struts to allow hands-free access.

The countertop in the kitchen and bath is made of a decor matching Corian. The "drawer" directly in front of the kitchen and lavatory sink does not pull out, but rather flips down. This provides a storage tray for dish cloths, scouring pads, wash cloths, etc.



Drawer guides are standard on all of the drawers throughout the unit. These guides provide a smooth opening and closing of the drawers. To open a drawer, lift up slightly and pull open. The way this mechanism works will prevent the drawers from unintended opening while traveling. The drawers are constructed with maple panel bottoms for added strength. All of the cabinets are equipped with positive door catches and knife hinges. The catches secure the door in the closed position for extra security when traveling.

All of the cabinetry can be easily cleaned with any commercial furniture cleaner or polish. As with any wood product, do not saturate these cabinets with water or any other liquid. Be sure to wipe up spills as they occur to avoid staining.

# FURNITURE

## *Living Room Area*

A standard feature in the kitchen area is the free-standing dinette. This includes a dinette table and four chairs. The chairs are designed with a coordinating upholstery fabric to match your decor. Depending upon the floor plan, the table will have either a glass or extension top.

In the living room of most models, the standard sofa is a Flexsteel sofa. This sofa is upholstered in decor matching fabric. If you have any questions regarding the warranty on this sofa, contact Flexsteel, the sofa manufacturer. An optional feature on most models would be the addition of the sofa storage cabinet.

The standard living room chair, on most floor plans, is the Flexsteel swivel glider/recliner. There are two optional chairs in place of the standard. They are the petite glider/recliner, and the swivel rocker. On most floor plans, the recliner end table with beveled glass top is standard. All floor plans receive the sofa cocktail table with the beveled glass top.

## *Bedroom Area*

The standard mattress in the bedroom is the queen size, luxurious pillow top mattress. One popular option is the bedroom vanity center. If the vanity center is optioned, a padded vanity stool is included.

## *Notes*

---

---

---

---

---

---

---

---

---

---

---

---

---

---

---

---

---

---

---

---

---

---

---

# CHAPTER 6

## STRUCTURE FEATURES

### *Table of Contents*

Frame Features .....	6 - 1
----------------------	-------

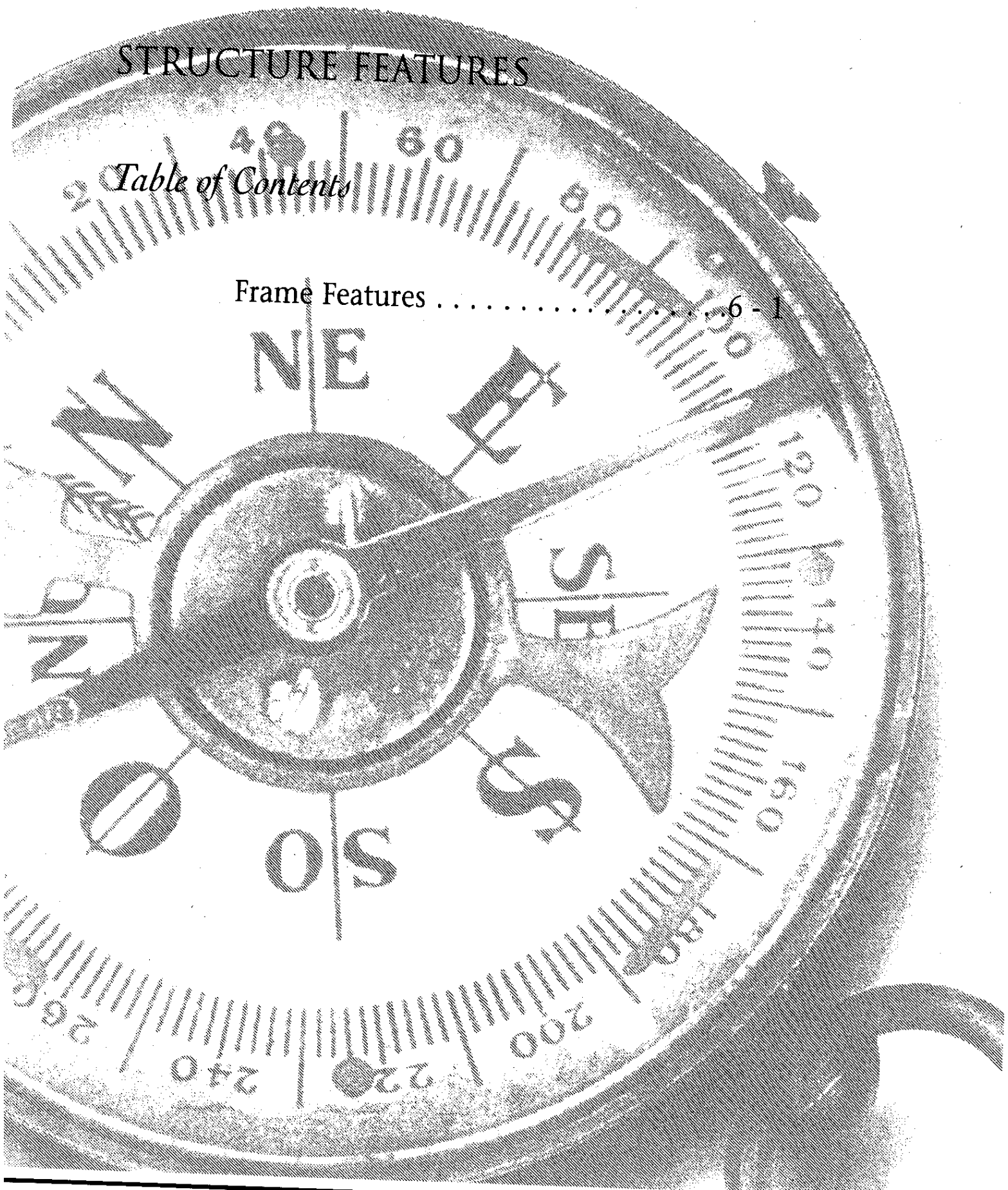

# STRUCTURE FEATURES

All models have 16" steel I-Beam frame construction with a fiberglass wrap for maximum storage capabilities. These frames are manufactured at the Newmar production facility. Doing this ensures the control of quality that Newmar insists upon.

Skid bars are installed on all models as a standard feature. These will help prevent accidental damage when encountering dips or steep inclines.

The tires installed on the unit, including the spare, are 16" radials. The wheels measure 16" x 6". All wheels, except for the spare, have stainless steel wheel simulators installed for added beauty. The bolt pattern on the wheel is 8 on 6½". The brake size is 12¼" x 3¾" while the axle capacity is 7,000 pounds.

All units are equipped with tandem axle dual wheels with Torflex suspension. This will help cushion the fifth wheel when going over rough, uneven roads. In addition, they assist in stabilizing the unit.



# CHAPTER 7

## ELECTRICAL FEATURES

### *Table of Contents*

General Information .....	7 - 1
Breaker Boxes .....	7 - 1
Batteries .....	7 - 1
Battery Inspection & Care .....	7 - 2
120 Volt Receptacles .....	7 - 3
GFCI Receptacles .....	7 - 3
Wiring Connector .....	7 - 4
Resettable Breakers .....	7 - 5
Generator Prep & Generator .....	7 - 6
Solar Prep .....	7 - 6



# ELECTRICAL SYSTEMS

## *General Information*

There are two electrical systems in your coach. They are the 12 volt DC system and the 120 volt AC system. Most standard appliances require the 120 volt system while the majority of the lighting used in recreation vehicles is powered by 12 volt. The power for the 12 volt system is supplied by the coach batteries. The power for the 120 volt systems is supplied by the power cord when the unit is connected to an outside power source or by the generator, if so equipped. When connected to shore power, the standard 75 amp power converter will automatically charge the batteries as well as convert 120 volts into 12 volts.

To connect the unit to 120 volt shore power, first make sure all of the breakers are in the off position. This is done to avoid a power surge. Unwind the power cord from the electrical compartment. The standard electrical service in this unit is 50 amps with a flexible 50 amp power cord. Check to make sure the pins in the outlet are oriented correctly, that they match the power cable, and that they are in good condition. If there is a circuit breaker switch at the plug, it should be turned OFF before making the connection. Insert the plug completely into the outlet and turn the circuit breaker on. Close, and lock the electrical compartment door to keep the contents clean, dry, and secure. Close the cover on the power box, if equipped, to avoid an unintended disconnection, and to keep contents clean. Switch the main breaker to the 'ON' position. The 120 volt system will energize all 120 volt circuits and outlets when the main breaker is turned on.

## *Breaker Boxes*

The 120 volt and 12 volt breaker boxes are generally installed in a bedroom cabinet. Circuit breakers and fuses are installed to protect the electrical system from overloading. Do not attempt to change the circuitry or add appliances yourself. Please consult an authorized Newmar Service Center.

## *Batteries*

The two 6-volt batteries on your unit are installed by Newmar, but are warranted by the battery manufacturer. They are used to operate the 12 volt items in the unit. The batteries also operate the water heater's electronic ignition, landing jacks, etc. The in-line breakers protecting these circuits are found near the batteries. If the tow vehicle is equipped with a charge line, the tow vehicle's electrical system will charge the coach battery while in transit. The power converter automatically charges the coach batteries when the unit is connected to a 120 volt outside power source.

## Battery Inspection & Care

### WARNING

Remove rings, metal watch bands and other metal jewelry before working around batteries. Use caution when using metal tools. If a tool contacts a battery terminal or metal connected to it, a short circuit could occur which could cause personal injury, explosion or fire.

### CAUTION

Disconnect the 120 volt electrical power cord and the negative terminal from the coach batteries before working on the electrical system.

Remember, when a battery is not used for an extended period of time, it may lose its charge. Periodic charging of the battery during storage of the unit will increase the life of the battery. Check the external condition of the battery periodically. Look for cracks in the cover and case. Check the vent plugs and replace them if they are cracked or broken. Keep the battery clean. Accumulations of acid film and dirt may permit current flow between the terminals, which could drain the battery.

To clean, wash the battery with a diluted solution of baking soda and water to neutralize any acid present. Rinse thoroughly with clean water. Foaming around the terminals or on top of the battery is a sign that acid is being neutralized. Avoid getting the baking soda solution in the battery. Secure all vent caps. Dry the battery cables and terminals. Do not use grease on the bare metal inside the cable terminals to prevent corrosion. Grease can act as an insulator. Electricity will not flow through it. A plastic ignition spray will protect the terminals after they have been cleaned.

### WARNING

Do not allow the battery fluid to contact your skin, eyes, fabric, or painted surfaces. The fluid could cause serious personal injury or property damage. Wear eye protection when working with any battery.

When storing the unit for a short period of time, the battery should be disconnected from the coach to prevent draining. Your unit is equipped with a battery disconnect switch. Simply push the switch to the "STORE" position when storing your unit. To use the unit again, simply push the switch to the "USE" position. When not using your unit for an extended period of time, the battery should be removed and stored in a warm place. Mark the cables, positive and negative, for easy identification. Batteries are not to be stored on concrete floors. The battery may require periodic charging during storage. If the unit is to be stored for a long period of time, it is recommended that all the batteries inside the unit be removed from clocks, radios, smoke alarms, etc. This will prevent unnecessary drain and corrosion of the batteries. The coach battery is a deep cycle RV/marine battery. This type of battery consumes water and must be filled periodically. Consult the owner's manual supplied by the battery manufacturer. This can be found in the Owner Information Package received with this unit.

## *120 Volt Receptacles*

For your convenience, there are 120 volt receptacles located throughout the interior of the unit. There are also exterior outlets located on the curbside of the coach. These receptacles require the three-pin plugs that provide proper grounding to protect you from electrical shock. Do not use an adapter, cheater, or extension cord that breaks the continuity of the ground circuit to the ground pin. Never remove the ground pin from a plug in order to connect it to a two pronged ungrounded outlet. Never operate the camping vehicle with an electrical short. An electrical short may cause the exterior of the unit to shock you when touched. If you feel even the slightest shock, disconnect the unit from the 120 volt power source and locate the fault. It is usually a break in the grounding circuit. The grounding circuit must be continuous from the frame to the distribution panel, to the power cord, to the earth ground.

## *Ground Fault Circuit Interrupt Receptacle*

The 120 volt electrical outlets in the kitchen and bath area are ground fault circuit interrupt (GFCI) receptacles. The GFCI outlets provide an overload and short circuit protection. The electrical outlets located in the slide out are wired through the kitchen GFCI. The exterior electrical outlets are wired through the bathroom GFCI. If an item plugged into a slide out or outside receptacle is not working, check for a tripped GFCI in the kitchen or bathroom. In addition, these outlets protect the user from ground faults between a hot wire and ground. The GFCI will not reduce the shock hazard if the short is between a neutral and hot wire, or two hot load wires.

The GFCI should be tested at least once a month. The 120 volt electrical system must be on in order to test the GFCI. The reset button needs to be pushed in all of the way before starting the test. Push the test button. This will cause the reset button to pop out which means that the protected circuits have been disconnected. Push the reset button back in until a click is heard. This will reactivate the protected circuit. If the GFCI is working properly the reset button will remain in the 'IN' position.

## *Electrical Diagrams*

Typical electrical diagrams can be found in chapter 15.

## *Notes*

---

---

---

---

---

---

---

---



# RESETTABLE BREAKERS

The resettable breakers are located within 18 inches of the source of power. This is the converter and the battery. (Figure 1)

When either of the breakers are shut down they must be manually reset.

To find the breakers, follow the line from the battery or converter approximately 18 inches.

This may lead to a junction box or to a cabinet inside the unit or similar location.

Manually reset the breaker as shown at right in Figure 2.

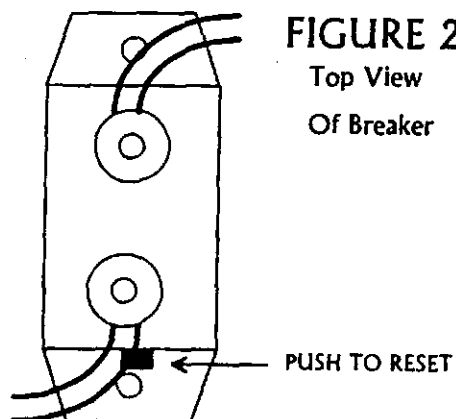

**FIGURE 2**  
Top View  
Of Breaker

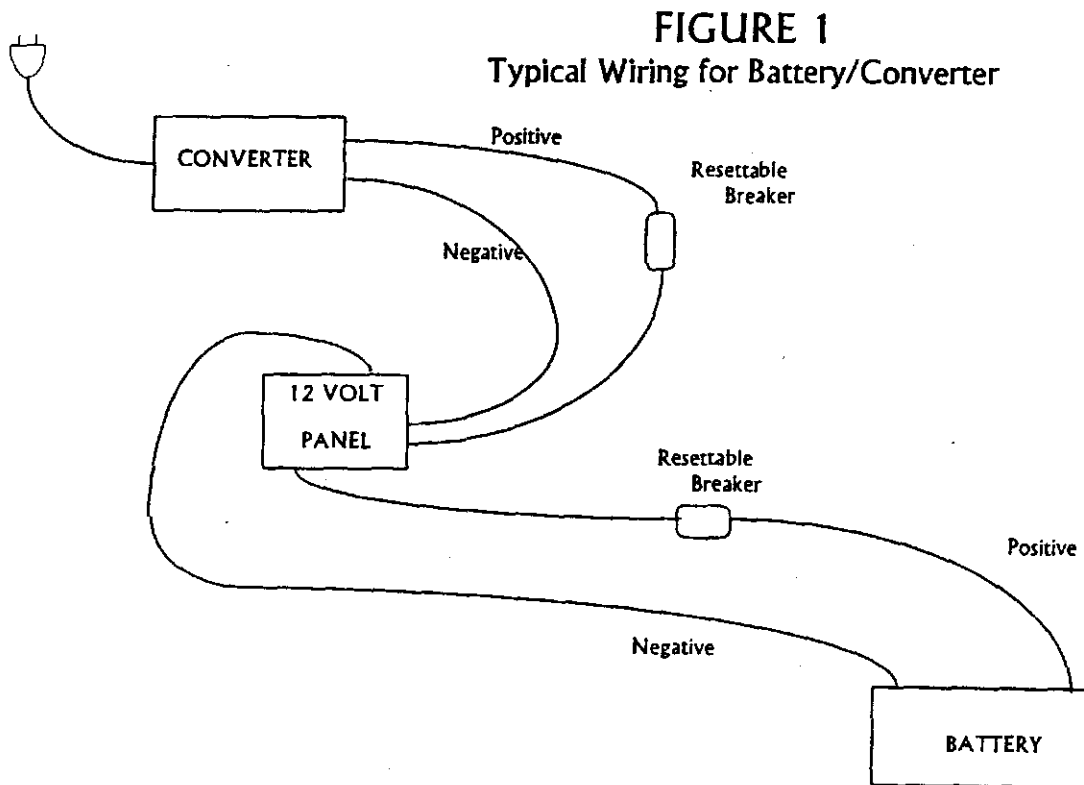

**FIGURE 1**  
Typical Wiring for Battery/Converter

## *Generator Prep (Optional)*

This option must be installed before the generator option. With this option, the remote start wire is installed in the unit along with the automatic change over switch and carbon monoxide detector.

## *Generator (Optional)*

As an option on this unit, a 5.5 KW Onan generator may be added. With the installation of the generator, your unit will have both a 50 amp automatic changeover switch and an additional battery. The standard generator operates off of gasoline. An LP conversion kit can be added to the generator. This will allow the generator to operate off of LP gas.

When the generator is running, it will produce 120 volt power. This will supply electricity to the appliances and 120 volt lights in the unit when not connected to shore power. There is an hour meter on the generator. The meter tracks the number of hours the generator has been running. This information is important for routine maintenance.

For further instructions on the generator operation and maintenance, please refer to the generator manufacturer Operator's Manual located in the Owner's Information Packet.

## *Solar Prep (Optional)*

The unit can be equipped with the wires necessary for the installation of a solar unit. The solar unit is not available from Newmar, but the wiring can be installed as an option.

## *Notes*

---

---

---

---

---

---

---

---

---

---

---

---

---

---

---

---

---

---

---

---

---

---

---

# CHAPTER 8

## SLIDE OUT FEATURES

### *Table of Contents*

General Instructions . . . . .	8 - 1
Extending . . . . .	8 - 2
Retracting . . . . .	8 - 2
Manual Operation . . . . .	8 - 2
Operating Precautions . . . . .	8 - 3

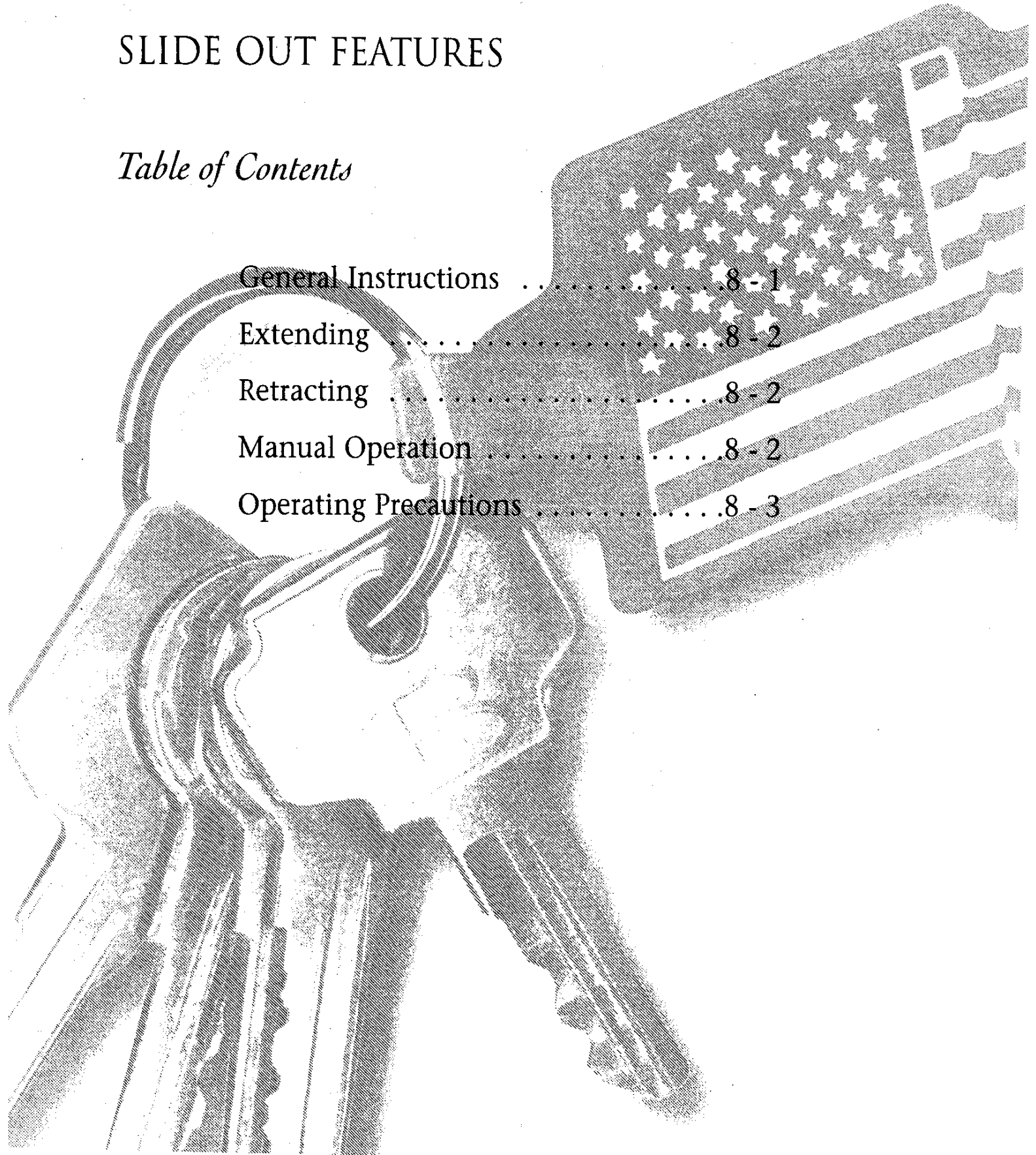

## WARNING

READ THE FOLLOWING SLIDE OUT ROOM INSTRUCTIONS BEFORE ACTIVATING THE SWITCH.

## IMPORTANT

The slide out room should be inspected for alignment every six (6) months. If alignment is necessary, have the room adjusted.

## GENERAL INSTRUCTIONS

1. The slide out room can be stopped at any time by activating the slide out switch. The room will reverse directions each time the switch is activated.
2. If the slide out room stops before reaching the full 'OUT' or 'IN' position, the slide out controller may need adjustment.
3. To adjust the slide out controller, turn the adjustment screw clockwise to increase the power and counter-clockwise to decrease the power.

## CAUTION

Move the adjustment screw in small increments. Try moving the slide out room again. Use caution. There is a potential for component or structural damage if the screw is adjusted too high.

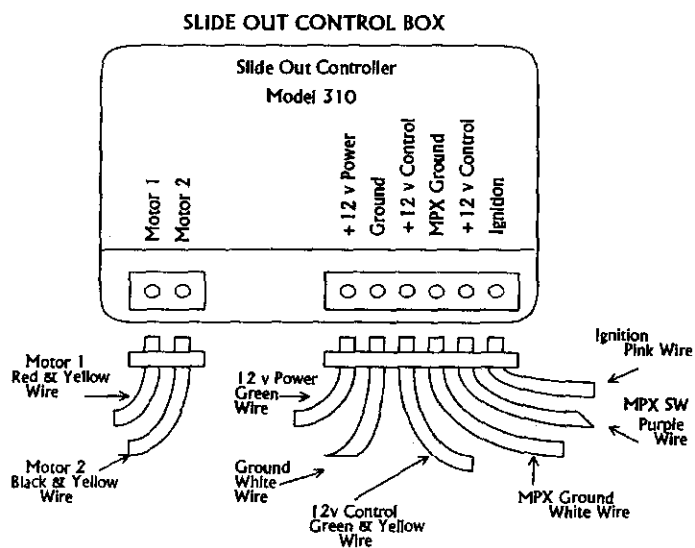
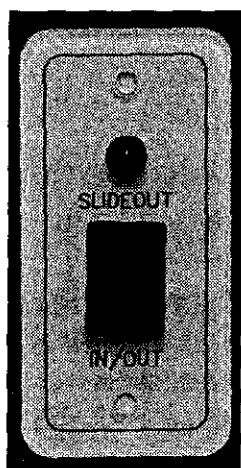

## IMPORTANT

This screw does not adjust the slide out room speed. It sets the amount of power required to move the room against the mechanical stops.



## *Extending the Slide Out Room*

1. The windows on the end of the slide out room must be closed before moving the room in either direction.
2. Before extending or retracting the room, look for and remove any obstructions.
3. Disengage the lock arms by pulling down on the center of the arm using the lock arm release tool, as required.
4. Activate the slide out switch. Once fully extended, the room will automatically stop. The indicator light will be lit while the room is traveling.

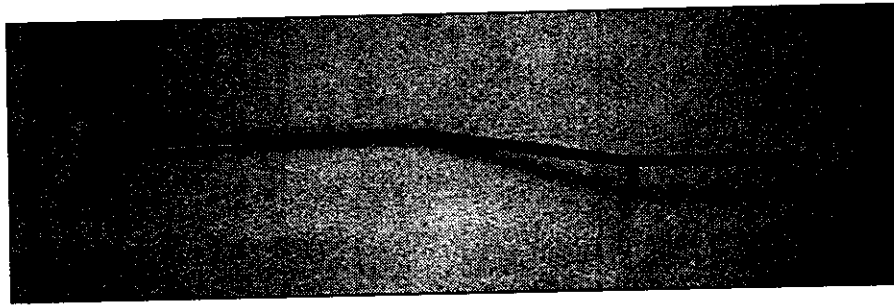

## *Retracting the Slide Out Room*

1. Activate the slide out switch. When fully retracted, the room will automatically stop. The indicator light will be lit while the room is traveling.
2. Before moving the coach, engage the lock arms by pushing the arm up into the locked position using the lock arm tool, as required.

## *Manual Extension & Retraction*

### SHAFT END-MOUNTED MOTORS

If the motor is mounted on the ends of the slide out shaft, use the following directions:

1. Access must be gained to the TRANS-TORQUE bushing coupling at the end of the slide out gear motor.
2. Using a ½" drive – 1½" open end crows foot wrench and a supplied ½" drive ratchet wrench, loosen the 1½" nut. This will require approximately 1½ turns. The nut is a standard right hand thread. After the initial release, the nut will turn for a partial turn, then will release again as you turn the wrench. This second release is required to loosen the TRANS-TORQUE bushing from the shaft.

### SHAFT CENTER-MOUNTED MOTORS

If the unit is equipped with the K-900 slide out motor which is mounted near the center of the slide out room, use the following directions:

1. Access must be gained to the slide out motor located in the center of the slide out room.
2. The manual extension or retraction requires only a  $\frac{3}{8}$ " socket and ratchet wrench. By placing the socket on the  $\frac{3}{8}$ " hex nut located on the gear box of the K-900 motor, the slide out can be moved in either direction by turning the hex nut.
3. If the slide out does not move by using the hex nut, the room can also be extended or retracted by using the procedure described for the SHAFT END-MOUNTED MOTORS.

Slide outs with either the center or end mounted motors can be moved by pushing the room the full length of its travel in either direction. This method will require the assistance of at least two people.

#### IMPORTANT

The TRANS-TORQUE bushing must be re-tightened to re-couple the slide out gear motor, and the lock arm must be engaged before moving the coach. This will hold the slide out room in place.

#### CAUTION

The correct torque on the  $1\frac{1}{4}$ " TRANS-TORQUE is 110 foot pounds maximum.

## *Operating Precautions*

Before extending the slide out, make sure that the unit is level.

#### WARNING

Before extending the slide out make certain that there is a minimum of five feet of clear space on the slide out side of the unit. Prior to extending the room, be sure to unlock the slide out locking arms.

Make sure there are no obstructions either inside or outside of the unit that may interfere with the slide out extension. Tree branches, bushes, or telephone poles can cause extensive damage to the exterior of the unit.

## *Notes*

---

---

---

---

---

---

---

# CHAPTER 9

## EXTERIOR FEATURES

### *Table of Contents*

Exterior Sides . . . . .	9 - 1
Jacks . . . . .	9 - 1
Stabilizer Jacks . . . . .	9 - 2
Roof . . . . .	9 - 2
Electric Steps . . . . .	9 - 2

# EXTERIOR FEATURES

## *Exterior Sides*

The sides of this unit are constructed of gel-coated fiberglass. To add to this feature, the front and rear end caps are also gel-coated fiberglass. Clean the fiberglass material with a mild cleanser and warm water. Use only soft cloths. Using stiff bristle brushes may cause scratches in the fiberglass surface.

## *Jacks*

Standard on these units are the 12 volt electrical fifth wheel jacks. Before using the jacks, read and closely follow the operation instructions provided by the jack manufacturer. To lift the unit for uncoupling, drop the pad tube by removing the lock pin. Re-pin the hole that places the foot pad closest to the ground to compensate for variations in the terrain between the jacks. Push the toggle switch to the "DOWN" position and hold until the jack raises the unit to the desired height.

### CAUTION

Before raising the jacks, make sure the hitch is securely latched by applying the trailer brakes and slowly pulling the tow vehicle forward. The unit should prevent the tow vehicle from moving.

To raise the jacks after coupling, push the toggle switch to the "UP" position and hold until the jacks are fully retracted. Release the toggle switch as the lock pin in the inner ram tube nears the end of the outside tube to avoid unnecessary wear on the motor clutch. Remove the lock pins and raise the pad tubes, re-pinning them in the highest possible position.

### CAUTION

When the jacks reach their maximum extended or retracted length or maximum load, you will hear a clicking noise. This is the slip clutch built into the motor to prevent jack overextension or retraction. Release the toggle switch as soon as you hear the clicking. Continued operation with the clutch slipping can damage the jacks.

These jacks can be operated manually, if necessary. Insert the hand crank into the alignment tube until the end engages with the crank shaft. Turn the crank handle counter clockwise to raise the trailer. Remove and store the crank handle. To raise the jacks after coupling, rotate the crank handle clockwise. Retract as far as possible with the crank handle, then remove the lock pin and raise the pad tube and re-pin it in the highest possible position. Please refer to the jack manufacturer Operation Instructions for further assistance.

The snaps for the fifth wheel jacks are a standard feature on this model.

## *Stabilizer Jacks*

This unit is equipped with stabilizer jacks. The operation of the stabilizer jack is fairly simple. First park the vehicle on level ground. Block the wheels using tire chocks to prevent the unit from moving. Level the front and the back of the unit using the tongue jack or landing gear. Crank the stabilizers down on the low side first, this will bring the trailer to a fine level position. Re-tighten the stabilizers on the low side of the unit, if necessary. Do not use stabilizer jacks to lift the unit.

### CAUTION

Before moving the trailer, crank up the stabilizer jacks to the fully closed position. Tighten  $\frac{1}{4}$  turn to secure the jacks in the travel position. This will help prevent the stabilizers from working open due to road vibration. Do not use stabilizer jacks to lift the unit.

## *Electric Stabilizer Jacks (Optional)*

In place of the manual stabilizer jacks, an electric stabilizer jack assembly can be optioned. For further instructions on the operation of these, refer to the manufacturer Operator's Manual in the Owner's Package.

## *Roof*

The standard roof on this unit is the gel-coated fiberglass roof. The roof and radius top wrap are made from gel-coated fiberglass, complementing the sides and front and rear end caps. On this model, the molded recessed ladder steps are incorporated into the rear cap.

## *Electric Steps*

Installation of the electric steps is a standard feature on this model. Operation for the electrical entrance door step is as follows;

1. With the entrance door open, turn the step power switch on.
2. Close the door. The step should retract and lock in the up position.
3. Open the door. The step should extend and lock in the down position.
4. Turn the step power switch off. The step should remain in the extended position with the under step light off when the door is closed. Turning off the power with the step retracted will hold the step in a retracted position as well.

### CAUTION

If the vehicle is towed with the step in the extended position, there is the possibility of causing major damage to both the step and the vehicle.



# CHAPTER 10

## INTERIOR FEATURES

### *Table of Contents*

Bedsread	4	10 - 1
Flooring		10 - 1
Ceiling		10 - 1
Window Treatment		10 - 1

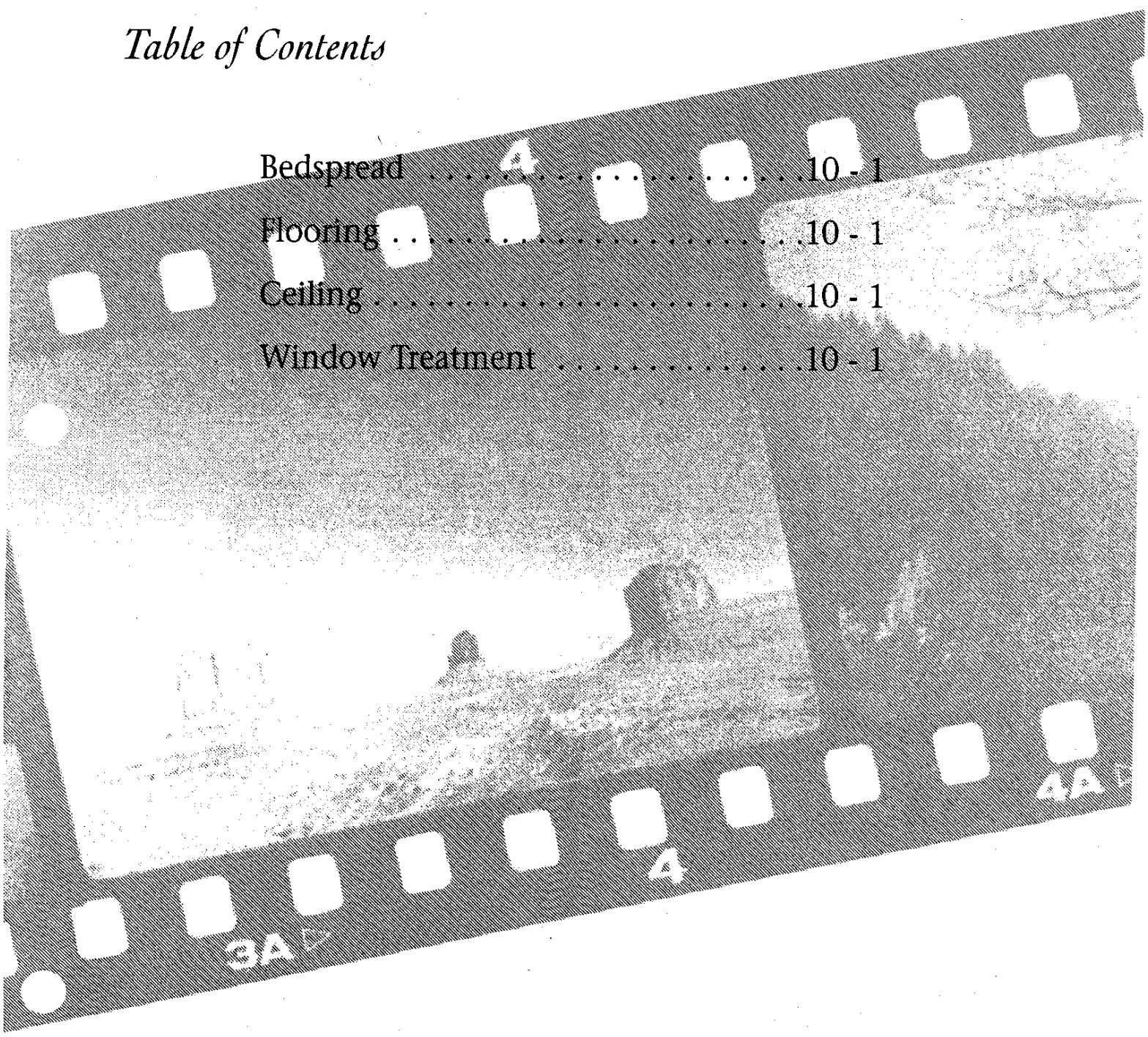

# INTERIOR FEATURES

## *Bedsread*

All units have a decor matching bedspread enclosed as part of the standard package. The recommended cleaning instructions for this spread are Dry Clean Only. The materials that make up the spread may have been treated and dry cleaning will preserve this treatment.

## *Flooring*

The floor covering in the living room and the bedroom of the unit is carpet. In the Owner's Package you will find literature supplied by the carpet manufacturer. This information will be helpful in maintaining and extending the life of the carpet. Please refer to this information for the carpet care and cleaning instructions. The floor covering in the kitchen, foyer area and bathroom is a decorative 8" ceramic tile. To clean this type of floor, use a mild soap with warm water and a soft cloth.

## *Ceiling*

The ceiling in this unit is covered with a padded, vinyl ceiling headliner. The cleaning instructions recommended would be a soft cloth and mild detergent.

## *Window Treatment*

The window treatment throughout this unit, except in the kitchen, is lined day/night, pleated soft shades with lambrequins. These shades have two sections. The first section visible when closing the shade is the "DAY" section. This material is translucent. Sunlight passes easily through the material into the unit. The second visible section is the "NIGHT" section. This material is a heavier, more opaque material. Very little to no light passes through it. It is generally used in the evening or when more privacy is desired. The kitchen window is equipped with a mini-blind.

## *Notes*

---

---

---

---

---

---

---

---

# CHAPTER 11

## PLUMBING & BATH FEATURES

### *Table of Contents*

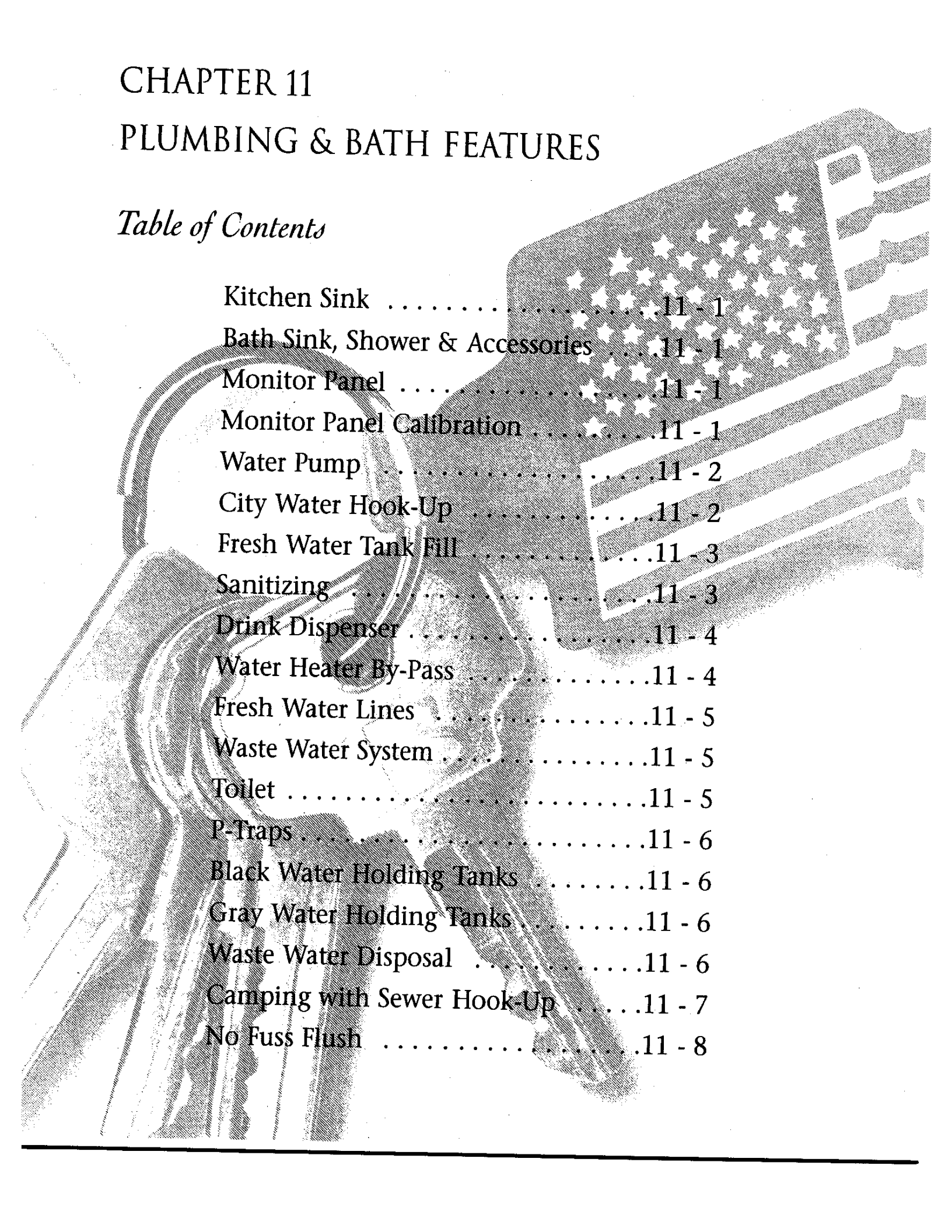

Kitchen Sink .....	11 - 1
Bath Sink, Shower & Accessories .....	11 - 1
Monitor Panel .....	11 - 1
Monitor Panel Calibration .....	11 - 1
Water Pump .....	11 - 2
City Water Hook-Up .....	11 - 2
Fresh Water Tank Fill .....	11 - 3
Sanitizing .....	11 - 3
Drink Dispenser .....	11 - 4
Water Heater By-Pass .....	11 - 4
Fresh Water Lines .....	11 - 5
Waste Water System .....	11 - 5
Toilet .....	11 - 5
P-Traps .....	11 - 6
Black Water Holding Tanks .....	11 - 6
Gray Water Holding Tanks .....	11 - 6
Waste Water Disposal .....	11 - 6
Camping with Sewer Hook-Up .....	11 - 7
No Fuss Flush .....	11 - 8



# FRESH WATER SYSTEM

## *Kitchen Sink*

The kitchen sink installed is a double bowl, Corian sink incorporated into the Corian countertop. The unit has two sink covers to provide additional counter space when the sink is not in use. In the Owner's Package furnished with this unit you will find care instructions for the Corian counter tops and sink in this unit. Cleaning care consists of washing with mild detergents and a soft cloth. Avoid using "S.O.S." type cleaning pads because they may scratch the surface. The faucet in the kitchen is an 8" chrome single handle Gourmet faucet by Moen.

## *Bath Sink, Shower & Accessories*

The sink in the bathroom is also made of Corian. The brass bathroom accessories include a towel bar, towel ring, tissue holder, and robe hook. The faucet in the bathroom is a brass single handle faucet by Moen. The shower installed is a fiberglass combination tub and shower enclosure. Some floor plans can have the corner shower option. The accessories accent the brass tub faucet, shower head, hose, and bracket.

## *Monitor Panel*

The monitor panel allows you to check the approximate levels in the fresh, gray, and black water holding tanks, and the battery condition. The monitor panel is generally located in the bathroom. Simply press the button of the item to check its status. The empty indicator light will always light when the button is pressed. If the tank is full, all of the lights will be on. Lights are sequential, and indicate the level in approximately  $\frac{1}{4}$  tank increments. For example: If the tank selected is approximately  $\frac{1}{2}$ -full, then the indicator lights E,  $\frac{1}{4}$ , and  $\frac{1}{2}$  will be lit. On the right hand side of the monitor panel is the water pump switch. This switch controls the power going to the water pump, turning it either on or off.

## *Monitor Panel Calibration*

The monitor panel comes to you factory calibrated for accuracy and should not need to be adjusted. In the event that the system does not read accurately, then re-calibration may be necessary. The procedure for re-calibration is simple: First, fill the tank to be re-calibrated. Second, using the adjustment tool enclosed in the Owner's Package (or any small flat-bladed screw driver) simultaneously push the button for that tank and rotate the adjustment screw located above the button and behind the face plate counter-clockwise until some of the lights turn off in sequence. Then slowly rotate the adjustment screw clockwise until the full light is completely on. Repeat this procedure as necessary for the remaining tanks. The system is now calibrated properly.

## *Water Pump*

The water pump is self priming and totally automatic, operating on demand whenever water is required. The water pump is used to pressurize the fresh water system when the unit is not connected to city water. To start the pump follow these instructions:

1. Fill or partially fill the fresh water supply tank.
2. Open the kitchen and bathroom faucets.
3. Turn the water pump switch on and allow the water to fill the water line and the hot water heater.
4. Close each faucet after it delivers a steady stream of water (close the cold water first). Leave the hot water faucets on until they also deliver a steady stream of water. This will ensure that the water heater is filled with water.
5. The water pump should stop running once all faucets are closed.
6. The pump is now ready for automatic operation. The pump will run when a faucet is opened and stop when a faucet is closed.
7. Never allow the pump to run for long periods of time without water in the supply tank. Pump damage or blown fuses may result.

If water doesn't flow when a faucet is turned on while using the demand system, use the following trouble shooting chart.

SITUATION	SOLUTION
Pump running - no water	1. Fill tank 2. Clear the water line to the pump
Pump doesn't run	1. Check the pump switch 2. Check the 12 volt fuses 3. Check the electrical connections 4. Check the battery

All of the water should be drained from the fresh water system when the unit is not in use for more than one week. For more detailed information regarding the water pump, refer to the water pump manufacturer's brochure in your Owner's Package.

## *City Water Hook-Up*

When connecting your unit to city water, be certain to use a water hose manufactured and labeled for potable water. This will ensure that the hose will not alter the taste of the water. To hook the city water supply to the unit, connect one end of the hose to the city water supply. This will usually be a faucet or valve similar to your garden hose valve at home.

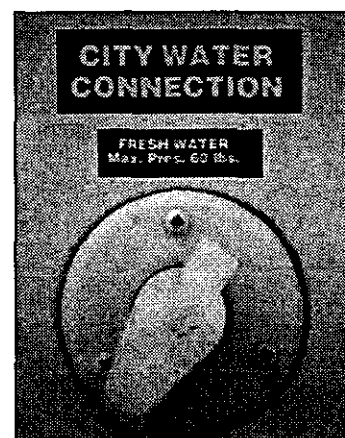

Turn the city water supply on for a few seconds in order to clear the line. Once the hose has been flushed, turn the supply off. Connect the other end of the hose to the city water connections. Turn on the water supply and open all of the faucets to clear the air from the lines in the unit. Once air pockets have been purged from the water lines and water flows freely, close all of the faucets. The city water supply is under pressure, therefore the water pump is not necessary when connected to city water. Once the city water fill valve is opened, water is supplied to the fresh water system including the hot water heater, faucets, and stool. To disconnect from the city water supply, close the valve and remove the hose from the city water supply. Disconnect the hose from the city water connection and store the hose in the water compartment.

## *Fresh Water Tank Fill*

The fresh water tank is filled from the city water hook-up. The water supply valve located in the service compartment near the water hook-up determines whether the city water is going through the water system or into the fresh water tank. An additional way to fill the fresh water tank is with the winterizing intake hose placed in a bucket of water (See Chapter 14). With the water supply valve open, turn on the water pump to fill the tank. Since there is not an automatic shut-off for the fresh water tank fill, check the level from the monitor panel while filling the unit. The excess water will be vented from an overflow vent pipe onto the ground when the tank capacity has been reached. This pipe is installed in the fresh water tank to prevent tank rupture from overflowing. All of the water should be drained from the fresh water system when the unit is not in use for more than one week. Whenever possible, drain the fresh water tank before traveling. Water in the tank will reduce the carrying capacity of the unit.

## SANITIZING

To assure complete disinfecting of your fresh water system, it is recommended that the following procedure be followed on a new system, on one that has not been used for a length of time, or one that may have become contaminated. This procedure is also recommended before long periods of storage, such as over the winter months:

1. Drain the fresh water tank by opening the drain valves. There is one valve per water tank. All of the faucets should be in the closed or off position.
2. Prepare a chlorine solution using one gallon of water and  $\frac{1}{4}$  cup of chlorine bleach (5% sodium hypo-chlorite solution). Prepare enough of the chlorine solution to administer one gallon of solution for every 15 gallons of tank capacity. For sanitizing this unit, prepare  $4\frac{1}{2}$  gallons of the chlorine solution. This mixture puts a 50 PPM (parts per million) residual chlorine concentration in the water system that will act as a quick kill dosage for harmful bacteria, viruses and slime forming organisms. Concentrations higher than 50 PPM may damage the water lines and/or tank.
3. Once the fresh water tank is empty, close the drain valves on the water tank.
4. Pump the chlorine solution into the tank. This is done by placing the winterizing hose into the chlorine solution. Close the valve from the fresh water tank to the pump and open the valve from the solution to the pump. Turn the tank fill valve from city water to tank fill. Turn on the water pump until all of the solution is pumped into the fresh water tank.

5. Turn off the water pump. Close the valve to the solution. Turn the city water valve to open. Open the valve from the tank to the water pump. Turn the water pump on in order to fill the tank with fresh water until it is completely full. Remove the water filter (from the drink dispenser faucet, if installed) and install the by-pass pipe to allow the sanitizing solution access to the faucet. Open each faucet in turn including the kitchen faucet, bath faucet, inside and outside shower, turning on both the hot and cold, and flushing the stool until all of the air has been purged from the pipes and the water runs freely. The entire system will then be filled with the sanitizing solution.
6. Allow the 50 PPM disinfecting solution to stand in the system at least four hours.
7. Drain the system and flush with fresh water. The water system needs to be flushed with clean water repeatedly, if necessary, until there is no chlorine taste or smell left in the system. To remove any excessive chlorine taste or odor that might remain, prepare a solution of one quart vinegar to five gallons of water. Allow this solution to agitate in the tank for several days by vehicle motion. Drain the solution and refill the tank with clean water.

## *Drink Dispenser with Water Filter*

Before disinfecting the fresh water system, remove the water filter and install the by-pass pipe to allow water access to the drink dispenser faucet if installed. The water filter is located under the kitchen sink. The filter will remove chlorine, dirt, and other matter. It will also eliminate most phenol (or similar) odors and tastes while delivering sparkling, taste free water for drinking and cooking. The filter is connected only to the cold water line that is attached to the drink faucet. The filter is not guaranteed to remove the tastes and odors of iron and sulfur. To remove these tastes you will need to chlorinate the water. Replacement filters are available that will filter iron and sulfur. Ask your dealer or RV supply center about acquiring an iron and sulfur filter. If you are traveling in an area where the water has a high iron and sulfur content, then add 1 tablespoon of chlorine bleach to every 10 gallons of water in your tank. This will precipitate the iron or sulfur so that the filter can remove it. If you are at a site where the unit is hooked up to city water, you will not be able to chlorinate the system because the water flows straight to your faucets and not through the fresh water tank. Filters should be changed every 6 - 12 months depending on the quality and quantity of water that is used in your unit.

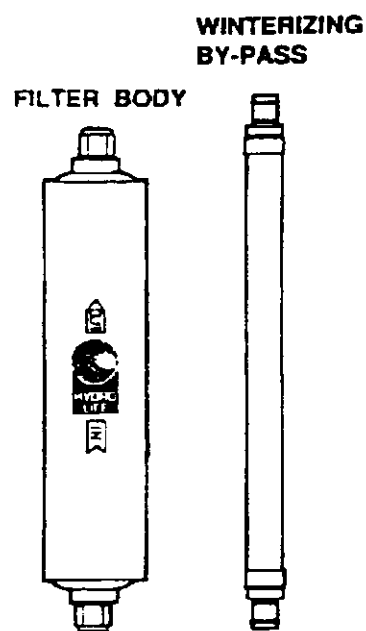

## *Water Heater By-Pass System*

The water heater by-pass valve is located at or near the water heater. By closing the water heater supply valve and opening the by-pass valve you can divert water away from the water heater. This is done when winterizing your unit. Using the by-pass will keep antifreeze out of the water heater when winterizing the system.

## *Fresh Water Lines*

Vibration and flexing during traveling can cause pipes and fittings to work loose. Check all of the plumbing connections for leaks on a yearly basis. If the water pump runs when all faucets are turned off, check for a leak. Be sure the drain valves are closed. Connections at the kitchen and bathroom faucets normally seal with hand tightening and a half turn with a wrench. If a fitting leak persists, disconnect it completely and check for mineral deposits or foreign material on the sealing surfaces. Clean the surfaces thoroughly and reinstall the fitting. Take the coach to an authorized service center for repairs if the system continues to leak. Follow the winterizing instructions given in Chapter 14 to reduce the risk of leaks caused by cracks from freezing pipes. Freezing damage can be extensive and expensive.

## WASTE WATER SYSTEM

### *General Information*

The waste drainage system was designed to provide adequate and safe storage and/or disposal of waste materials. All of the material used in the making of this system are tested by a nationally recognized testing laboratory. The drainage system uses ABS plastic piping and fittings connected to the sinks, toilet, and holding tanks. This provides for their drainage to an outside termination. The unit should be reasonably level for best operation of the system. There are two separate waste systems. The gray water system is for waste water from the sinks and shower. The black water system is generally for sewage waste from the stool. Each tank has its own control valve and both tanks drain through the sewer drain hose.

### *Toilet*

The stool operates with water from either the fresh water tank with the water pump on or the city water supply. Before using the stool, add water to the bottom of the tank. Refer to the 'BLACK WATER TANK' instructions in this chapter. The stool flushes wastes directly into the black water holding tank. The stool uses high velocity water injection to produce a swirl effect in the bowl. The greatest problem that causes stool solids to build up in the holding tank is lack of liquids. When using your stool, it is wise to fill the stool 3/4 full of water. This will help to wash the solids away from directly below the stool and to ensure complete dumping of the holding tank. Depending upon the model installed, water can be added to the stool bowl by lifting up on the lever. To flush the stool, push down on the lever until water swirls.

The stool requires little maintenance. Use an approved non-abrasive cleaner to clean the bowl. Spraying the bowl sealing blade with a silicone spray will retain the original smooth operating condition.

Check the complete instruction and trouble shooting guide in the stool manufacturer's Owner's Manual provided in the Owner's Package.

## *P-Traps*

Each of the sink drains, the shower drain, and the washing machine drain (if equipped) has a water trap (P-Trap) to prevent holding tank odors from entering the coach. These traps must have water in them in order to work. While traveling, the water may splash out of the sink and shower drains. While stored, the water may evaporate allowing an odor to enter the coach. If this occurs, run water from the faucet into the drain, allowing water to fill the trap.

## *Black Water Holding Tank*

The black water, or sewage, holding tank is located directly beneath the toilet. Before using the stool, you will need to treat the tank with water that is mixed with an odor controlling chemical. These chemicals are readily available at any RV supply store. Be careful not to spill the chemical on your hands, clothing or the carpet because it may cause a permanent stain. Pull the toilet levers forward to allow the chemical to mix with the toilet water. Continue pulling the toilet levers until at least one inch of solution is directly under the toilet. Release the levers and the waste tank is ready for use.

### CAUTION

Use only approved RV odor controlling chemicals in the holding tanks. Products containing ammonia and petroleum will damage the ABS plastic holding tanks and seals.

## *Gray Water Holding Tank*

The gray water holding tank is located in the underbelly of the unit. It is primarily used for the drainage from the kitchen and bath sinks and the shower.

## *Waste Water Disposal*

Both of the holding tanks terminate in a valve arrangement that permits draining each tank separately or together. It is recommended to drain the black water tank before the gray water tank. This will allow the water from the gray tank to wash the black water residue from the drain lines and hose. The valves that open to release the water are called gate valves. The blade that closed the opening in the sewer drain pipes is connected to the T-handle to release the contents of the tank(s) when pulled. The sewer line must be securely capped during self-containment use to prevent leakage of waste material onto the ground or pavement. Do not pull the holding tank gate valve open when the protective cap is installed on the pipe. Always drain the tank into an acceptable sewer inlet or dump station.

### WARNING

Holding tanks are an enclosed sewer system and must be drained into an approved dump station. Both black and gray water holding tanks must be drained and rinsed thoroughly on a regular basis in order to prevent the accumulation of harmful or toxic materials.

Whenever possible, drain the holding tanks prior to traveling. The carrying capacity of your unit will be reduced if water is left in the black or gray tanks.

The holding tanks should only be drained when they are at least  $\frac{3}{4}$  full. Doing this will provide sufficient water to allow the complete flushing of waste materials in the drain lines and hose. If the tanks are not  $\frac{3}{4}$  full, add enough water to allow for sufficient flushing.

To empty the waste water tanks, connect the adapter to the drain hose. Use the adapter supplied with your unit. If the adapter is lost or broken, one can be purchased from most RV supply stores. Once you have placed the adapter on the drain hose, it can remain there for the life of the hose. Unscrew the cap off the drain. Connect the hose with the adapter in place to the drain fitting. Open the gate valve all the way by pulling on the T-handle. The tank will start to drain as soon as the T-handle is pulled. After you have drained the black water tank, immediately drain the gray water tank. Doing this helps to flush the black water from the sewage hose.

When both of the tanks are empty, flush them with a fresh water rinse before you close the valves. The gray tanks are easily flushed by pouring a couple of gallons of water into a sink drain. Prime the system with an odor control chemical following the directions above for preparing the system for use. The drain outlet is engineered for quick release of the drain hose adapter. Always close the gate valves and secure the end cap to prevent leakage while in transit. After draining, add enough water to the black water tank to cover the bottom.

When using dump stations for draining the holding tanks, keep other travelers in mind. Practice good housekeeping. Leave the dump stations in good order. Above all, do not pollute.

## *Camping with Sewer Hook-Up*

When camping at parks with sewer hook-up, it is important to keep the black water holding tank gate valve closed at all times, except when dumping. The gray tank can be kept open while hooked to a sewer connection but again, the black water tank must be kept closed. This is done so that an ample supply of liquid remains in the tank to provide a smooth flow through the gate and drain valve when dumping. Sufficient liquid in the tank causes a swirling action that should take any accumulated solid wastes with it. Accumulation of solid wastes in the black water tank can be avoided by keeping the gate valve closed when connected to the sewer hook-up. If the valve is left open, solid wastes may accumulate in the tank. This may eventually result in costly repairs.

### CAUTION

The gray tank valve needs to be in the open position when operating the optional washing machine.

## *No Fuss Flush*

This unit is equipped with an flushing system for the holding tanks. When draining your sewer tank, attach a water hose to the Sewer Spray hookup. After the tank is drained, leave the gate valve open and open the water valve to allow water to spray inside the sewage tank. This will clean the inside of the tank of any debris that may be left inside the tank. After this is done, disconnect the water hose and close the gate valve. When unsure if any solids are still left inside the tank, fill the sewage tank with approximately ten gallons of water through the stool. As you travel, the agitation of the water should help liquefy any solids left in the tank. You can dump the sewage tank again at your next destination.

### CAUTION

Do not use the same hose for the No Fuss Flush that is used for filling the fresh water tank

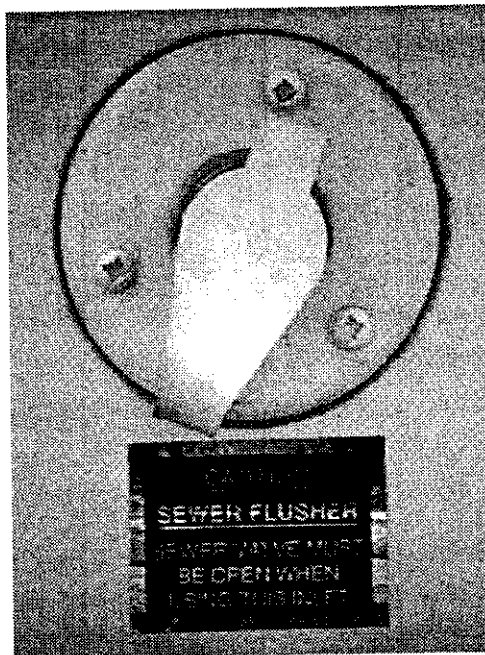

## *Notes*

---

---

---

---

---

---



# CHAPTER 12

## CONSTRUCTION FEATURES

### *Table of Contents*

Construction Features . . . . .	12 - 1
---------------------------------	--------

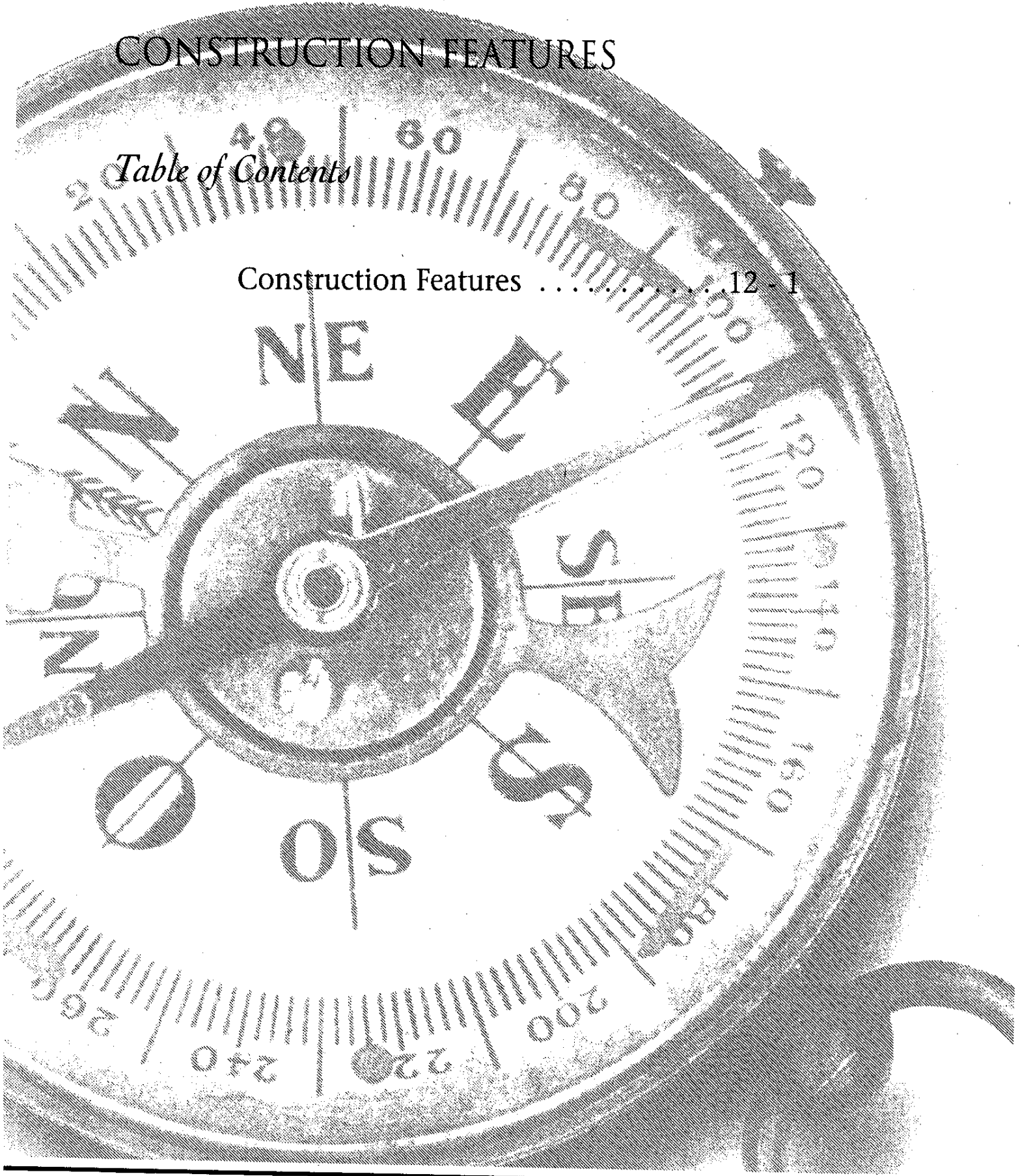

# CONSTRUCTION FEATURES

The floor decking is constructed of durable  $\frac{1}{2}$ " structure wood. The fiberglass insulation in the floor is rated at R19. The underbelly on these models is enclosed with aluminum laminated  $\frac{5}{8}$ " foam board. The rear bumper pulls out with a slide out tray for the spare tire.

Each of the sidewalls are constructed for strength and are heavily insulated for comfort. Welded, for additional strength, the widebody extruded aluminum sidewalls and roof are built with 16" on center framing, providing the strongest and most durable construction. The inside consists of  $\frac{5}{8}$ " beaded foam that is laminated to kraft paper and covered by the interior paneling. A blanket of rolled insulation is added to the sidewalls, roof, and slide out to provide a greater efficiency and consistency of climate control. The sidewall insulation is rated R7, while the roof is rated R19. In addition, under the exterior roof is a layer of  $\frac{1}{4}$ " foam board insulation. This will assist the furnace in the winter by keeping the warm in and the cold out. In the summer months, it will assist the air conditioning by keeping the cool air in and the hot air out.

Below are examples of the framing and insulation that your unit is constructed with.

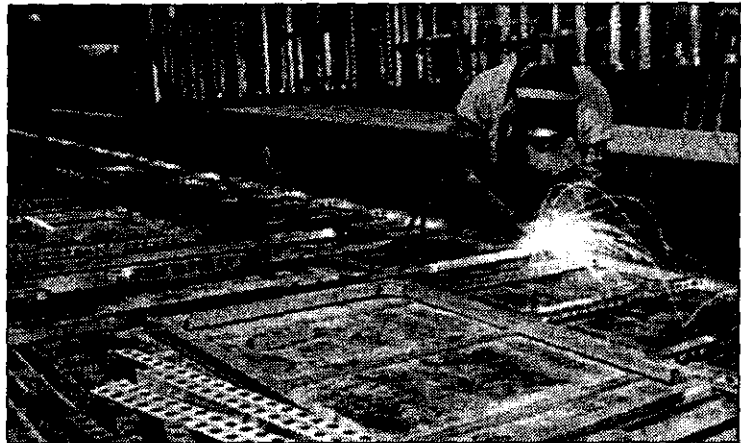
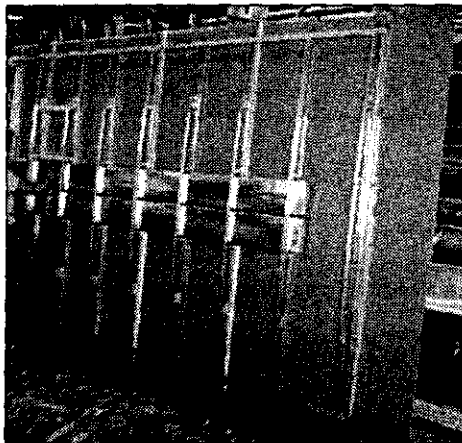

# CHAPTER 13

## WINDOWS, AWNINGS, VENTS & DOORS

### *Table of Contents*

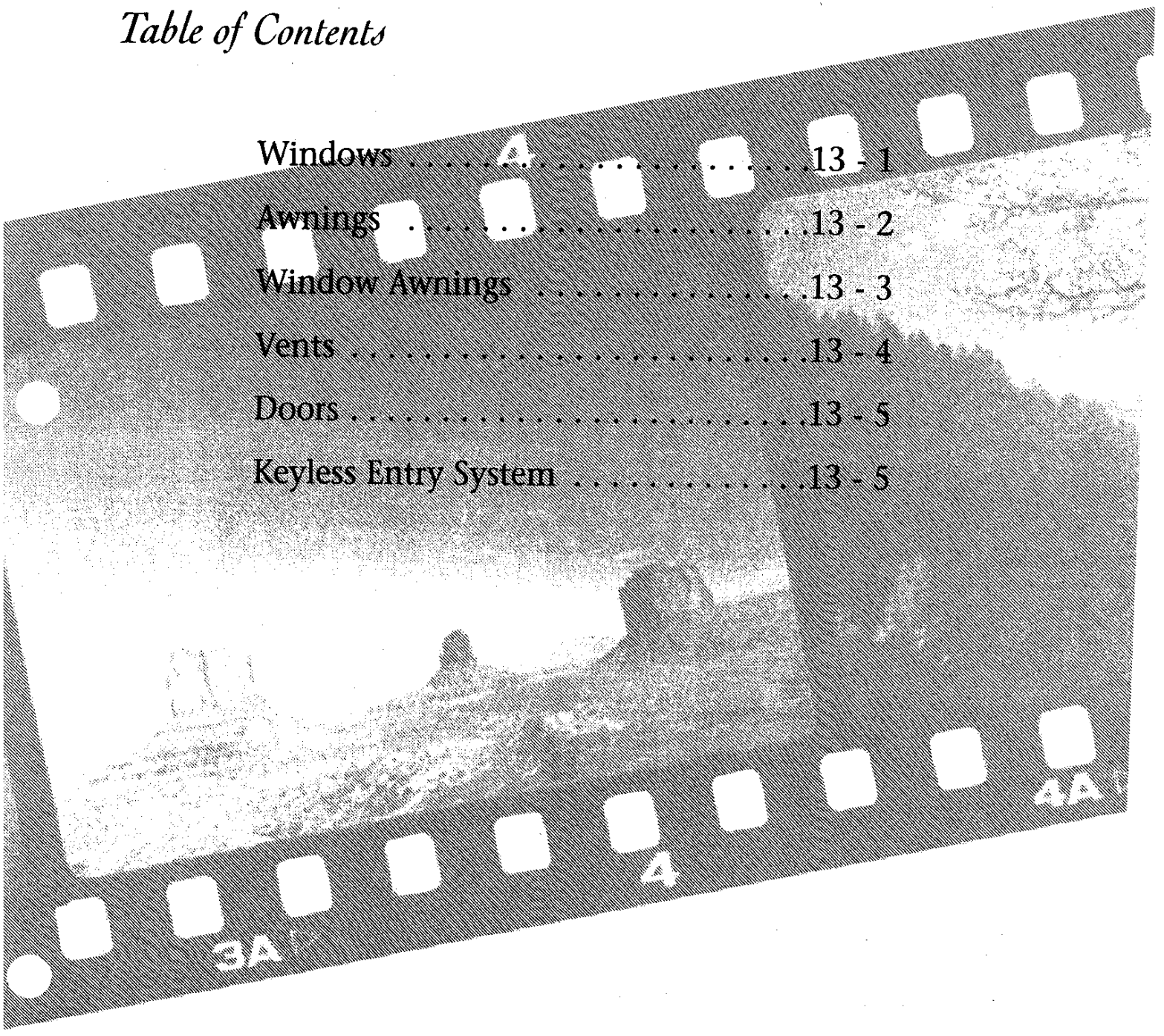

Windows .....	13 - 1
Awnings .....	13 - 2
Window Awnings .....	13 - 3
Vents .....	13 - 4
Doors .....	13 - 5
Keyless Entry System .....	13 - 5

# WINDOWS

The windows installed in this unit are the radius torque style. These windows are also referred to as jalousie windows. They open with the simple turn of a crank. There are two window options in this model. One is to have safety glass storm windows installed. The other would be the installation of dark tinted, safety glass storm windows.

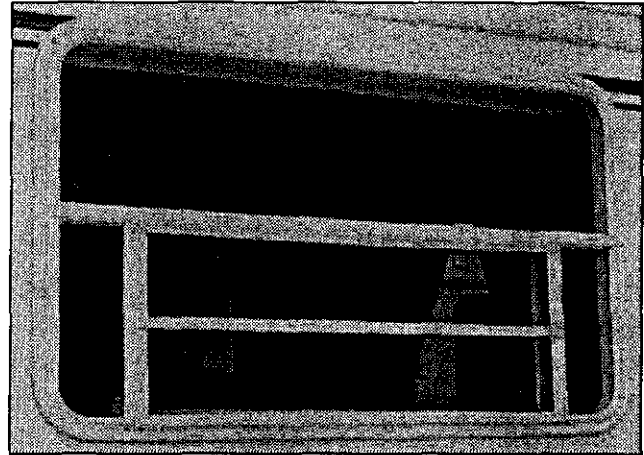

In the bedroom of the unit, one window will be marked "EXIT." This window is an emergency escape, or egress, window. To open in case of an emergency, lift the red handles at the bottom of the window and push out.

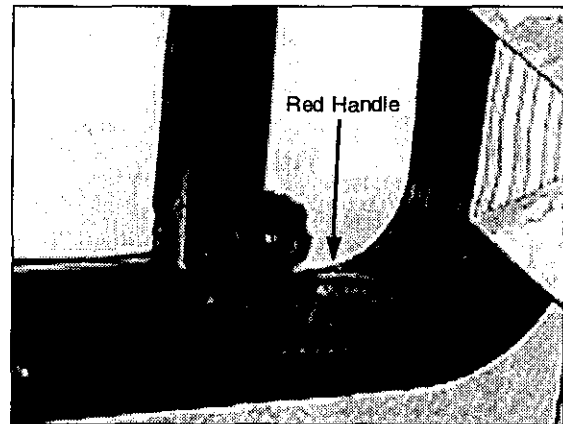

## *Notes*

---

---

---

---

---

---

---

---

---

---

---

---

---

---

---

---

---

---

---

---

---

---

---

# AWNINGS

## *Side Awning*

The side awning is a standard feature on this unit. With this standard awning, the awning side tension rafter can be added as an option. To operate, follow these instructions.

### EXTENDING

1. Loosen the black adjustment lock knob behind each main arm. Flip the travel lock latches up.
2. Using the provided pull rod, reach up and pull the locking lever forward or down to release the awning.
3. Hook the rod into the loop of the pull strap and pull the awning all the way out.
4. Slide one rafter arm up until it snaps into place. Push down on the main arm to remove slack from the fabric, and tighten the black adjustment knob. Repeat on other side.
5. Slide the pull strap to the right end of the roller and wrap it around the main arm.
6. Pull up on the lift handle and raise the arm assembly to the desired height. Swing handle in, and allow the lock button to snap into one of the holes. Repeat on the other side.
7. Press the release lever at the bottom end of one main arm, pull the arm assembly outward to a vertical position, and readjust height. Repeat on other side. Drive provided stakes through holes of each patio foot into the ground.
8. During rain, lower one end to allow water to flow off.

#### CAUTION

Whenever heavy or prolonged rain or wind is anticipated, or you will leave the awning unattended, it is best to close the awning. Damage as a result of weather is not covered by warranty.

### RETRACTING

1. Pull the stakes from the ground, swing the arm toward the vehicle, and snap the patio foot into the bracket. Repeat on the other side.
2. Raise the lift handle to release the lock button. Lower the main arm to the stop plug. Swing the handle in to engage the lock button in a hole. Repeat on other side.
3. Loosen black adjustment knob, lift slider catch, and slide the rafter arm down to the bottom of the main arm. Leave the black adjustment knob loose. Repeat on other side.
4. Grasp the pull strap and pull toward you. Flip the locking lever to the ROLL UP position. Hold the awning in the down position until you are ready to roll up the awning.

#### CAUTION

The awning will try to roll up as soon as the locking lever is flipped to the "ROLL UP" position.

5. Slide the pull strap to the center and using it to control speed, allow the awning to return to the side of the vehicle. Allow the strap to wind diagonally to prevent a bulge in the fabric.
6. Tighten the black adjustment knob and flip the travel lock latch down. Repeat on other side. The awning is now ready for travel.

## Window Awning (Optional)

Also optional on this unit, are the matching window awnings for the bedroom and the slide out room windows. To operate these, use the following instructions:

### EXTENDING

1. Grasp the loop on the pull strap and pull down to extend the awning. Then hook the loop onto the window strap hanger.

### RETRACTING

1. Remove loop on the pull strap from the window strap hanger.

#### CAUTION

Do not release the strap as the window awning is under tension and may snap back against the vehicle.

2. Slowly allow the awning to roll back to the closed position by feeding the pull strap upwards and diagonally. This prevents the strap from building up and creating a bulge in the fabric.
3. The window awning is now ready for travel with no further locking required.

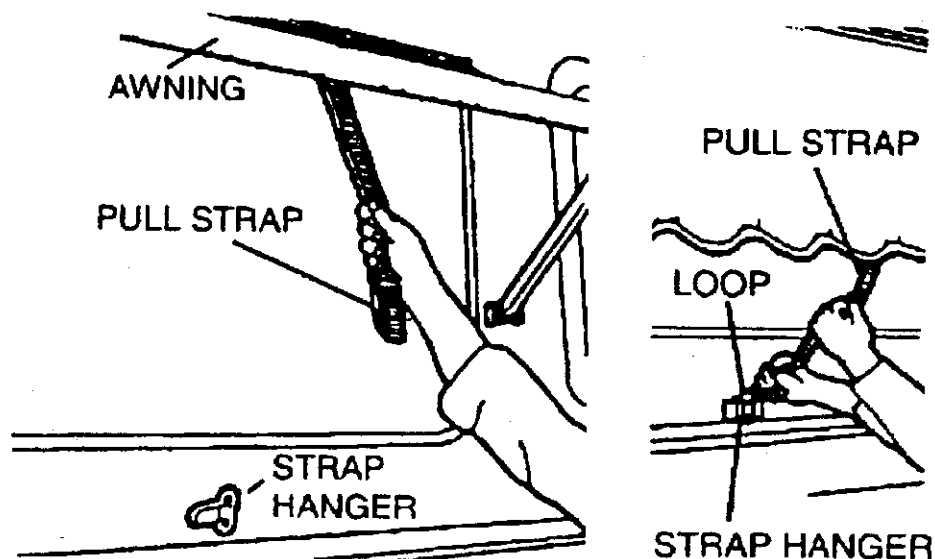

## Vents

There is one standard vent in the unit. It is located in the bath area. This vent operates on 12 volt electricity. The vent is controlled by an on/off switch on the wall.

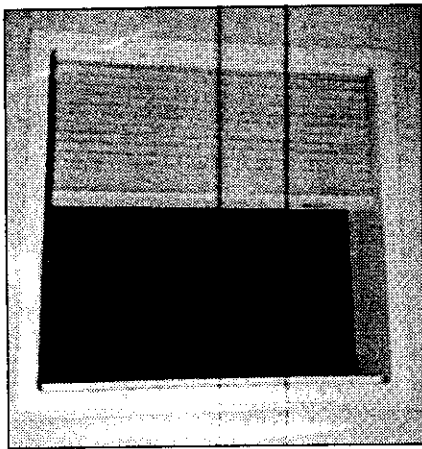
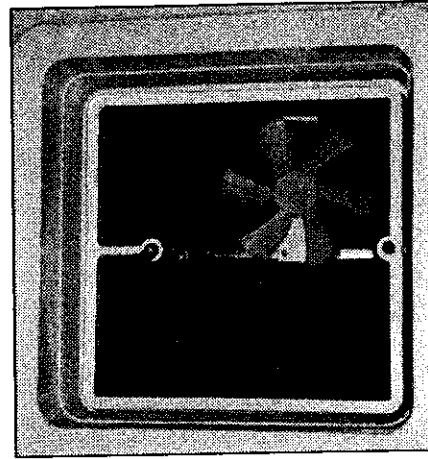

With the standard installation of the skylight in the bathroom, there will be a soft shade installed on the skylight for privacy. To open or close the shade, simply move the bottom rail in the direction desired.

In the kitchen, a possible option would be the installation of a 12 volt Fantastic Vent with rain sensor. This vent is controlled by the wall thermostat. When on, it will run until the desired temperature is reached. If, while the unit is on, it starts to rain, the sensor will automatically shut the unit off and the vent cap on the roof will close.





## *Doors*

The entrance door is a radius door with a dead bolt lock and lighted step for added security and visibility. The door lock is a keyless lock. Choose the code you wish to use and set the lock for that code. To lock or unlock the door, simply enter the code. The door can be held open with the patented automatic door stop. When the door opens, the holder in the door extends to catch in the receiver on the exterior sidewall. Next to the entrance

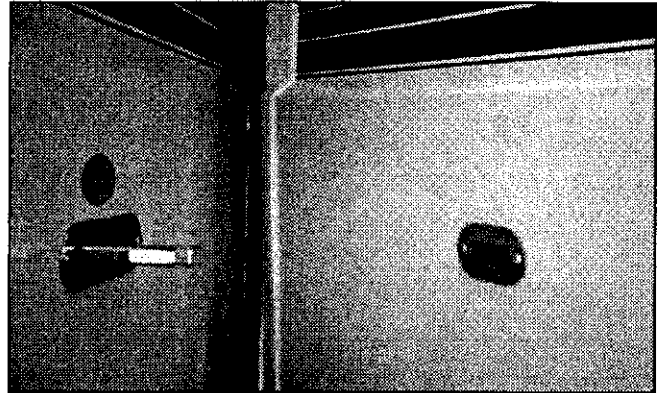

door you will find the lighted acrylic assist handle. This handle will assist anyone entering the unit. Next to the exterior handle, you would find the button for the door bell. This door bell operates on four C cell batteries.

## *Using the Keyless Entry System*

This vehicle has been equipped with a keyless entry system. The key chain provided with your unit can lock or unlock the entrance door by the simple press of a button. To lock the door, press and hold in the "II" button on the key chain. To unlock, press and hold the "I" button. This will lock or unlock the entrance door lock, not the dead bolt lock. The dead bolt must be locked or unlocked with the key provided.

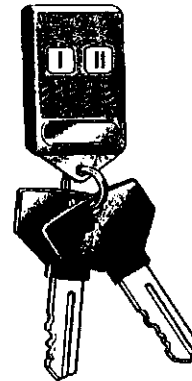

## *Notes*

---

---

---

---

---

---

---

---

---

---



# CHAPTER 14

## ROUTINE MAINTENANCE

### *Table of Contents*

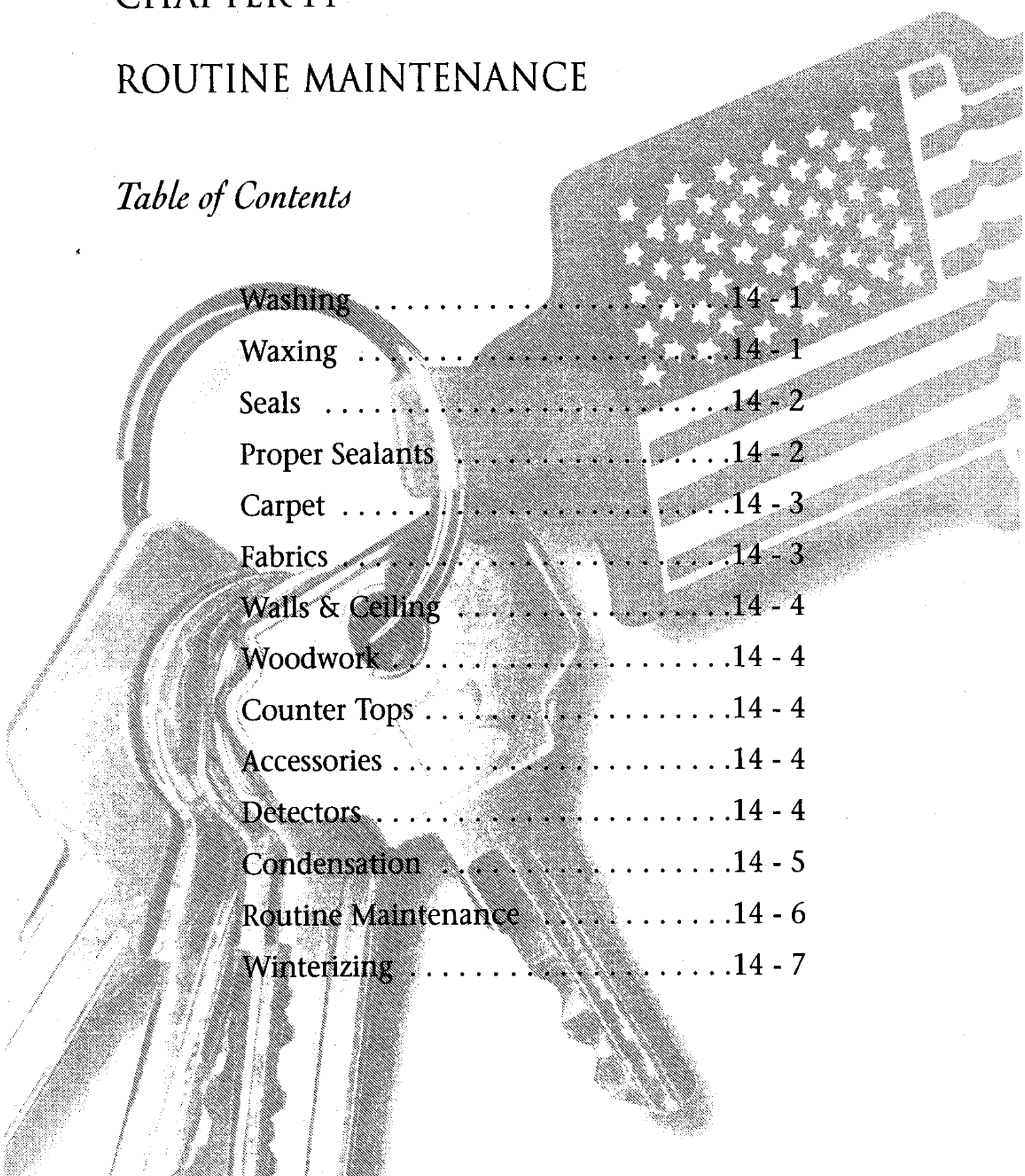

Washing .....	14 - 1
Waxing .....	14 - 1
Seals .....	14 - 2
Proper Sealants .....	14 - 2
Carpet .....	14 - 3
Fabrics .....	14 - 3
Walls & Ceiling .....	14 - 4
Woodwork .....	14 - 4
Counter Tops .....	14 - 4
Accessories .....	14 - 4
Detectors .....	14 - 4
Condensation .....	14 - 5
Routine Maintenance .....	14 - 6
Winterizing .....	14 - 7

# EXTERIOR CARE

## IMPORTANT

Damage caused by improper or unapplied maintenance is not covered by your Newmar Limited Warranty.

## *Washing*

The exterior of your new camping vehicle is made of pre-finished aluminum and/or fiberglass. Frequent washings and thorough cleanings are required to prevent damage to the vehicle finish after exposure due to damaging salts, calcium chloride, road tar, tree sap, insects and other foreign material. Damage caused by exposure to these items is not covered by your Newmar Limited Warranty. Never wash the vehicle in direct sunlight, while the vehicle is hot or with hot water. Build up of mud and dirt under the body can cause damaging rust on steel parts. Corrosive materials, such as those used for ice and snow removal and dust control, also accumulate on the underside of the vehicle. These materials should be removed by spraying the underbelly regularly with water, especially areas where mud and other foreign materials collect. The chance of corrosion can be minimized by frequent washings of the vehicle. When washing the vehicle, make certain that the undercarriage and the wheel wells are cleaned, as well as the exterior of the coach. Do not use strong soaps or detergents for washing the vehicle. Always use a mild soap in warm water, a commercially prepared product for automotive finishes or your local car wash. Be careful when using a pressure-type washer to avoid loosening any exterior decals or sealants, etc. After washing, carefully inspect the caulking around window frames and vents and any other joints that may have separated. Recaulking, if necessary, is relatively simple, and is considered routine maintenance which is the responsibility of the owner.

## IMPORTANT

Never use a strong solvent, such as lacquer thinner or harsh abrasives, on any of the exterior painted surfaces.

## *Waxing*

The exterior finish will require a routine waxing. When water will not bead and roll off a freshly washed vehicle, a new coat of wax is needed. Wax not only improves the appearance of the vehicle, but it also protects the finish against oxidation and corrosive materials. The recommended type of wax is one that is compatible with painted or gel-coated fiberglass finishes, and contains a UV (ultra-violet) inhibitor. Buffing with a polishing compound will improve a dull or discolored finish.

## IMPORTANT

When using a polishing compound that does not contain a wax preservative, reapplying a coat of hard wax after polishing is recommended.

## Seals

The seals around doors, windows, vents, slide out trim and external seams should be checked at least twice a year. In addition, the roof seams should be inspected twice a year for cracking or peeling. If deterioration is noted during a routine maintenance inspection, reseal the seams or seals with an approved sealant to prevent leaks. Your dealer can perform the resealing inspections and work for you. It is recommended that a Newmar Authorized Service Center perform these inspections, and reseal when necessary.

## Proper Sealants for Application

Plas-T-Cote	.....	Metal or fiberglass roof
Surebond #SB-140	.....	ALL SKYLIGHTS
Carlisle #502-LSW Self Leveling Sealant	.....	Rubber roof
Silicone Sealant	.....	To cover butyl and other sealants, not to be used as the main sealant
Parbond	.....	To seal across tops of windows, etc. on exterior where silicone is not used

## INTERIOR CARE

### WARNING

Urea-formaldehyde is used in the productions of particle board, hardwood plywood, and most paneling. Urea-formaldehyde resin may release formaldehyde vapors into the air, which may cause headaches, and in some people, eye, nose and throat irritation. Formaldehyde may intensify some allergies or upper respiratory problems like asthma. Proper ventilation should reduce the risk of such problems.

### IMPORTANT

The fading of upholstery, carpet and other interior fabrics is generally caused by excessive sunlight. The drapes, blinds or shades should be kept closed when the vehicle is parked for an extended period of time to minimize the fading. Normal deterioration of appearance items due to wear and/or exposure is not covered by the Newmar Limited Warranty.

## *Carpet*

A weekly routine of vacuuming the carpet and fabrics throughout the vehicle is recommended. Doing this will prevent an accumulation of dirt that can detract from the material's appearance and shorten its life.

Included in the Owner's Information Package is the carpet manufacturer's Carpet Care Guide. The Carpet Care Guide lists detailed information on cleaning soiled areas and removing stains from the carpet installed in the unit.

## *Fabrics*

The fabrics used in this unit for the bedspread, draperies, headboard and valances may contain fire-retardant additives that can be damaged by use of improper cleaning products.

**Water-based products are not recommended for cleaning the fabrics in your new unit.** Most water-based household cleaning products are not formulated for use on these fabrics and may cause excessive shrinkage or fading. Always test any cleaning product on a hidden area of fabric before using on visible areas. For best results, the fabrics in this unit should be cleaned by a professional carpet and upholstery cleaner.

Spills, spots or stains should be treated as soon as possible to avoid permanent damage. If a spill occurs, blot the fluid with a dry towel. Do not rub the spill. Rubbing may cause the liquid to "set" in the fabric. When attempting to clean a spot or stain, always start from the outside and work inward to avoid spreading it further. Some stains or soils are extremely difficult or impossible to be removed completely. These should receive immediate, professional attention. Spills, spots, stains or soils are the responsibility of the owner, and are not covered by the Newmar Limited Warranty.

### WARNING

When cleaning the upholstery and fabric in the unit, do not use lacquer thinner, nail polish remover, laundry soaps or bleach. Never use carbon tetrachloride or gasoline for cleaning purposes. These items may cause damage to the materials being cleaned and most are highly flammable.

## *Walls & Ceiling*

The wall and ceiling coverings should be cleaned periodically to maintain a new appearance. Use a non-abrasive cleaner with a soft cloth. Do not use solvents of any kind. Solvents may damage the surface.

## *Woodwork*

The wood cabinetry should be cared for with furniture polish to sustain the natural beauty and luster of the wood. This will also keep your cabinetry looking new and prevent the wood from drying. The simulated plank flooring should be protected from dents, scratches and nicks by installing protective pads on the bottom of chairs and tables. Use of area rugs and floor mats by the entrance door is recommended to trap dirt. To clean the flooring, begin by

vacuuming the floor to remove loose dust and dirt. Then, damp mop the floor with one ounce of Wilsonart Flooring Cleaner diluted in one gallon of clean, warm water (or use a non-abrasive, soap-free cleaner). The mop should be damp, not dripping. Do not use soap-based cleaners, scouring powders, steel wool, abrasive cleaners, wax or polish on the floor. To remove stubborn spots like shoe polish, oil, tar, markers, scuff, etc., use a household solvent, acetone or nail polish remover; then wipe with a damp cloth. To remove chocolate, grease, juice or wine, use warm water and a non-abrasive cleaner. To remove candle wax or chewing gum, carefully scrape off when the material has hardened. For further tips, please see the manufacturer's information sheet in your Owner's Information Packet.

## *Counter Tops*

To care properly for the Corian® counter top in your new unit, always use a heat pad or trivet to protect the surface from hot objects that may mar or damage the surface. Wipe the counter top with a damp cloth to remove water spots. For most dirt and stains, wipe with soapy water or ammonia-based cleaners. For watermarks, wipe with a damp cloth then towel dry. Occasionally disinfect by wiping the surface with diluted household bleach (one part water/one part bleach).

## *Accessories*

The brass light fixtures, bath accessories, and faucets can be cleaned by wiping with a soft, damp cloth. Washing with warm water will remove dry water spots. Do not use cleaners that contain harsh or abrasive chemicals. Alcohol or similar solvents should never be used.

## *Detectors*

The LP and CO detectors (if equipped) are self-contained and DO NOT require any maintenance other than normal cleaning and dusting. When cleaning the exterior of the case use a damp cloth or paper towel. Do not spray cleaners or wax directly into the case as it may cause false alarms.

## *Condensation*

### IMPORTANT

Since surface condensation within the coach cannot be controlled by the manufacturer, damage caused by condensation is not covered by your Newmar Limited Warranty.

Damage may occur to your unit if excessive condensation exists. Accumulation of condensation on surfaces within your unit occurs when warm, moist air contacts a cool surface. It is most evident on the inside of windows. This problem can be controlled by:

1. Slightly opening a window or roof vent to allow the moisture to escape from the unit.
2. A small dehumidifier is also very effective in removing moisture from the air.

- Condensation levels are highest during times when a person is cooking or taking a shower in the unit, but these are not the only times condensation is present.
- Condensation can migrate through ceiling panels and saturate the fiberglass insulation in your ceiling cavity. This condition often causes the occupants to believe the recreational vehicle has a roof leak. Walls and ceiling panels may also become wet when the moisture accumulates on these surfaces.
- Newmar Corporation does not recommend the use of unvented catalytic heaters.

## ROUTINE MAINTENANCE

All routine maintenance is the responsibility of the owner and is not covered by the Newmar Limited Warranty. Use the maintenance record found in Chapter 15 to record all performed maintenance as required. Please note that damage caused by improper or unapplied maintenance is not covered by the Newmar Limited Warranty.

Items supplied by other manufacturers may require specific individual maintenance not listed herein. Please refer to the manufacturers' suggested maintenance guidelines in the Owner's Information Packet.

### IMPORTANT

Cosmetic adjustments and alignments must be performed within the first three (3) months from date of original purchase for warranty consideration. Thereafter, these items are considered routine maintenance.

### *Every Trip*

- Check brake operation prior to towing.
- Check the tire pressure of all tires.
- Torque all wheel lug nuts.

### *Every Three (3) Months*

- Clean range hood exhaust fan filter and blades.
- Test smoke alarm and LP gas detector.
- Check operation of windows, latches and hinges.
- Clean the roof-ducted air conditioner filter(s).
- Clean and inspect all door and window seals; reseal where necessary.
- Inspect and reseal around the tub and shower area when necessary.
- Lubricate the exterior door hinges and latches with a graphite (silicone) lubricant.
- Check, clean and tighten battery cables, and inspect battery for proper fluid level.

## *Every Six (6) Months*

- Inspect the slide out for proper seal. If realignment is necessary, please contact an Authorized Newmar Service Center.
- Inspect the exterior rubber slide out seals and apply a UV inhibitor, such as 303 Protectant.
- Rotate tires as recommended by the tire manufacturer.
- Check all gas appliances for proper operation.
- Have the LP system inspected by a qualified technician.
- Lubricate the moveable parts on the entrance step.
- Check the wheels and lug nuts for cracks, and check the torque of the lug nuts.

## *Annually*

- Inspection of roof seams and joints should be performed by an Authorized Newmar Service Center. If resealing is necessary, it is the owner's responsibility and is not covered by the Newmar Limited Warranty.
- Sanitize the fresh water system.
- Have the axle bearings repacked, wheel seals replaced and brakes inspected.
- Wax the vehicle as previously described in this chapter.

## *Winterizing*

To store your unit for the winter months, it is necessary to winterize the water system to help prevent freezing. To do this, follow these instructions:

1. The water heater must remain off during this process. Shut off the water pump and make sure the water supply valves are closed. Disconnect the city water fill.
2. To drain the fresh water tank, open the drain valves.
3. Open the low point drain valves. There is one drain valve for each water line, one cold and one hot. This is done to drain all of the water out of the system.

4. After the water heater has cooled off, remove the drain plug to drain the water from the water heater. In the exterior compartment beside the water heater there are two water heater shut off valves and a by-pass valve. The shut off valves must be closed and the by-pass valve must be open, prior to winterizing to prevent the antifreeze solution from entering the water heater.

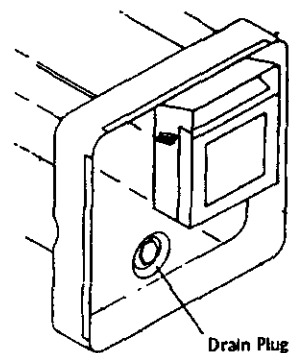

5. Close the low point drains to prevent the antifreeze from draining through the lines onto the ground.
6. Close the water supply valve that flows from the pump to the tank.

7. Use only non-toxic antifreeze that has been approved for use in drinking/potable water systems. Place the in-take hose into the antifreeze supply. Open the antifreeze valve to allow the solution to flow freely. Once the water pump is turned on, proceed to the kitchen faucet, bath faucet, inside and outside shower, turning on the hot and cold, and flushing the stool until the antifreeze solution flows freely. If the unit is equipped with a washer, be certain to purge the air from it also. This forces the antifreeze through all of the water lines and faucets. It also allows the antifreeze solution to enter the drain lines and prevent the P-traps from freezing. Check the antifreeze solution from time to time to make sure there is an adequate supply.
8. Close the antifreeze valve when the winterizing process is complete. Store the in-take hose, and turn the water pump off.
9. Open the water supply valve that flows from the pump to the tank to help prevent freezing on that water line.
10. To de-winterize your unit, open both of the low point drains to allow the antifreeze solution to drain from the water system. Next, close the low point drains and connect your unit to city water. Put water in the fresh water tank and pump at least one gallon through the water pump in order to remove the antifreeze from the water pump. Keep the water heater supply valve closed and the water heater bypass valves open. The supply valve for the fresh water tank from the pump must remain closed. As in winterizing, open the kitchen faucet, bath faucet, inside and outside shower, turning on both the hot and the cold, and flushing the stool until the antifreeze solution is flushed out of the system and the water flows clear. Once the system has been flushed, open the water heater supply valve and close the water heater bypass valve. Open the fresh water tank supply valve from the pump and the ice maker valve. Reinstall the water filter. Be sure to close the fresh water tank drain valves to allow the tank to fill.

## *Notes*

---

---

---

---

---

---

---

---

---

---

---

---

---

---



# CHAPTER 15

## CHARTS & DIAGRAMS

### *Table of Contents*

Model Numbers . . . . .	15-1
Maintenance Record . . . . .	15-2
Fuel & Mileage Log . . . . .	15-5
12 Volt Distribution Panel . . . . .	15-7
50 Amp Electrical Panel . . . . .	15-9
Wiring Color Scheme . . . . .	15-11
Typical 110 Volt Wiring Diagram . . . . .	15-15
Typical 12 Volt Wiring Diagram . . . . .	15-17
TV / VCR Wiring Diagram . . . . .	15-19
Typical Fresh Water Diagram . . . . .	15-21
Typical Drain Line Diagram . . . . .	15-23
Slide Out Mechanism . . . . .	15-27
Parts Listing . . . . .	15-29

# IMPORTANT INFORMATION ABOUT YOUR LONDON AIRE FIFTH WHEEL

Coach: Year 1999 Model \_\_\_\_\_ Serial # 5 \_\_\_\_\_

Appliance	Brand	Model	Serial
Refrigerator .....	_____	_____	_____
Water Heater .....	_____	_____	_____
Range .....	_____	_____	_____
Converter .....	_____	_____	_____
Washer .....	_____	_____	_____
Dryer .....	_____	_____	_____
Microwave .....	_____	_____	_____
Icemaker .....	_____	_____	_____
Television, front .....	_____	_____	_____
Television, rear .....	_____	_____	_____
Radio .....	_____	_____	_____
CD Player .....	_____	_____	_____
Generator .....	_____	_____	_____
Air Conditioner, front .....	_____	_____	_____
Air Conditioner, rear .....	_____	_____	_____
Video Cassette Recorder (VCR)	_____	_____	_____
Furnace, front .....	_____	_____	_____
Furnace, rear .....	_____	_____	_____

# MAINTENANCE RECORD

DATE	MILES	DESCRIPTION OF SERVICE WORK PERFORMED	SERVICE PERFORMED BY	COST	

# MAINTENANCE RECORD

DATE	MILES	DESCRIPTION OF SERVICE WORK PERFORMED	SERVICE PERFORMED BY	COST

# MAINTENANCE RECORD

DATE	MILES	DESCRIPTION OF SERVICE WORK PERFORMED	SERVICE PERFORMED BY	COST



# FUEL, OIL & MPG RECORD

DATE	ODOMETER MILEAGE	FUEL GALS.	OIL QTS.	AVE. MPG	COST	

DATE	ODOMETER MILEAGE	FUEL GALS.	OIL QTS.	AVE. MPG	COST	

# 12 VOLT DISTRIBUTION PANEL

**HOT FEED LINES FROM BATTERIES  
AND CONVERTER, WITH  
OVERCURRENT PROTECTION**

**GROUND TO CHASSIS,  
CONVERTER AND BATTERIES  
MINIMUM SIZE #8**

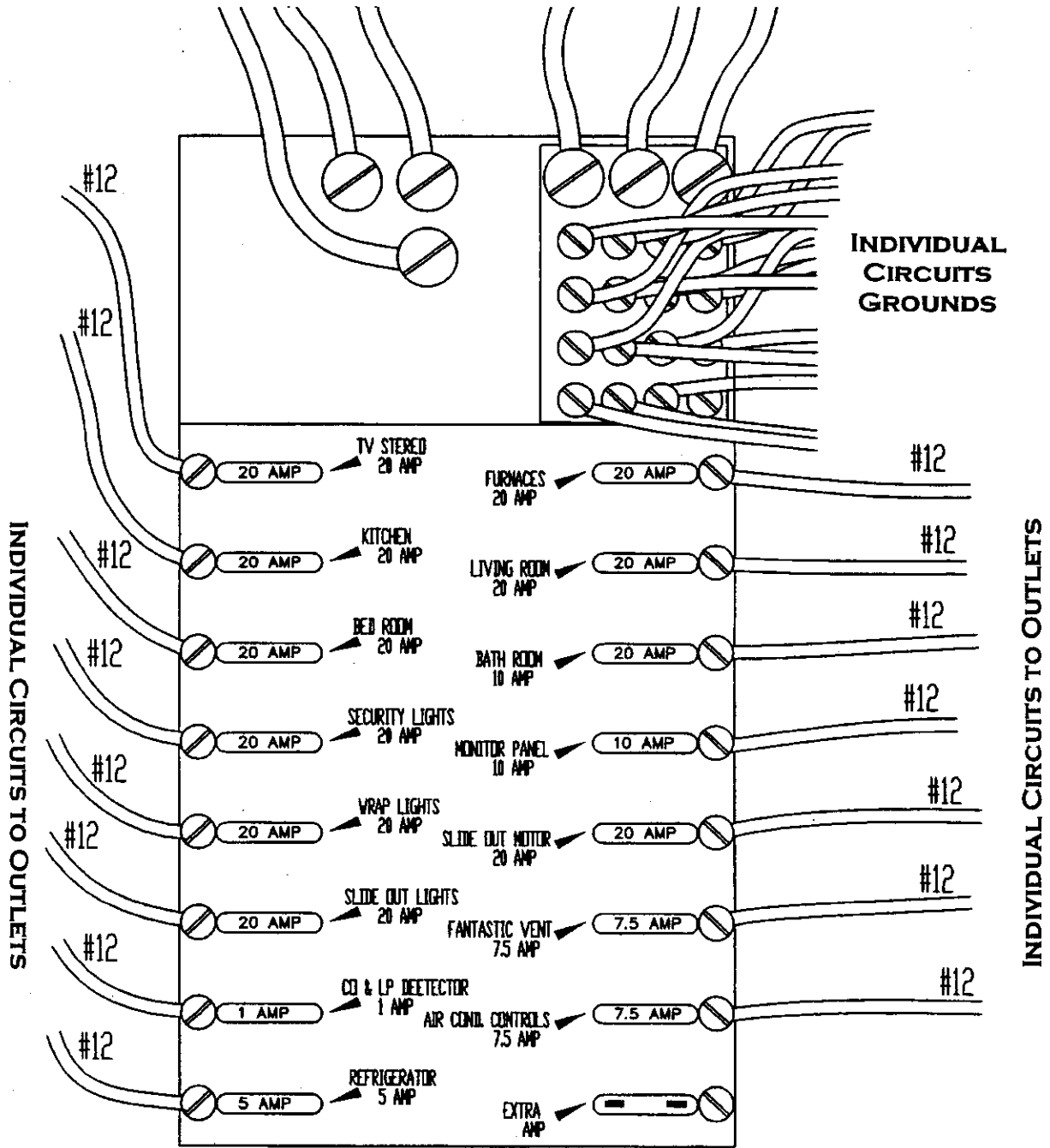

**WIRE OVER CURRENT PROTECTION IS PER THIS CHART**

WIRE SIZE	AMPACITY	WIRE SIZE	AMPACITY
# 6	55	# 8	40
#10	30	#12	20
#14	15	#16	8
#18	6		



# 50 AMP ELECTRICAL PANEL

load	protection	50 AMP MAIN		protection	load
1st AIR COND.	# 1 20 AMP			# 13	MAY HAVE 10 RECEPTS
MICROWAVE	# 2 15 AMP			# 14	MAY HAVE 10 RECEPTS
2nd AIR COND.	# 3 15 AMP			# 15	MAY HAVE 10 RECEPTS
WATER HEATER	# 4 15 AMP			# 16	DISHWASHER
REFRIGERATOR	# 5 15 AMP				
FOOD CENTER & 5 RECEPTS	# 6 15 AMP				
CONVERTER & 5 RECEPTS	# 7 15 AMP				
DRYER	# 8 20 AMP				
WASHER					

This is a 50 Amp 220 service

50 Amp lead in cord to box = 6/3 w/ground  
 20 Amp circuit wire = 12/2 w/ground  
 15 Amp circuit wire = 14/2 w/ground

Maximum of 10 outlets (lights and receipts) on any 15 amp circuit with no other appliance on that line. Circuits 3, 4, and 16 may have receipts as noted at left. NOTE: A duplex receipt is counted as 1 receipt.

This is a fully loaded system for which there has been a calculation done. Not all units will get all of these items. This diagram is a typical only

# WIRING COLOR SCHEME

## 16 GAUGE

Grounds	.White
Back-up Lights	.Yellow
Ignition to Power Step	.Pink
Clearance & Running Lights	.Green
Right Turn Lights	.Brown
Left Turn Lights	.Red
Ignition to Slide Out Motor	.Pink w/Green
Class A Blower Fan (in holding tank area)	.Orange
Slide Out Switch	.Purple
Courtesy Lights (hot to switch)	.Grey
Courtesy Lights (switched)	.Grey w/White
Detectors, CO & LP	.Red w/Black
Rear Center Brake Light	.Blue
LP Fuel Gauge	.Red w/Yellow
Air Conditioner Controls	.Pink w/Black
Monoplex Water Pump Switch	.Yellow w/Black
Vent Thermostats	.Black

Water Heater DSI Switch Harness	}	Red w/White*
		Green w/White*
		Blue w/White*
Onan Generator	}	Red w/White*
		Green w/White*
		Blue w/White*
		Brown*
Powertech Generator	}	Blue*
		Gray*
		Yellow*
		White*

\* - multiple applications for this color

# WIRING COLOR SCHEME (CONT.)

## 12 GAUGE

Grounds	White
Living Room & Entryway Lights (hot to switch)	Red
Living Room & Entryway Lights (switched)	Red w/White
Bedroom Lights (hot to switch)	Orange
Bedroom Lights (switched)	Orange w/White
Bathroom Lights (hot to switch)	Brown
Bathroom Lights (switched)	Brown w/White
Kitchen Lights (hot to switch)	Green
Kitchen Lights (switched)	Green w/White
Wrap & Storage Compartment Lights	Black
TV and Stereo	Pink
Furnaces	Green w/Black
3 Way Switches (commons)	Red w/Black
Electric Brakes (tandem axle)	Blue
Fantastic Vent and Water Heater	Brown w/Black
Monitor Panel	Yellow
Refrigerator Controls	Purple w/White
Security Lights (hot to switch)	Purple
Security Lights (switched)	Purple w/White
Slide Out Module (hot feed)	Green/Yellow
Slide Out Motor & Voice Module	Black w/Yellow & Red w/Yellow
Slide out Lights	Grey
Water Pump	Yellow w/Black
Power Step Switch	Black w/White

# WIRING COLOR SCHEME (CONT.)

## 10 GAUGE

Grounds .....	.White
Living Room Entry Lights (hot feed) .....	.Red
Bedroom Lights (hot feed) .....	.Orange
Kitchen Lights (hot feed) .....	.Green
Bathroom Lights (hot feed) .....	.Brown
Power Rear Awning & Freezer .....	.Purple w/Yellow
Power Step (hot feed) .....	.Green w/Black
Power Jacks .....	.Yellow
Electric Brakes (tri-axle) .....	.Blue
100 Watt Inverter .....	.Red w/White

## 8 GAUGE

Grounds .....	.White
Battery .....	.Red
Converter .....	.Black
Solar Prep .....	.Green

## 16 GAUGE

### **MONITOR PANEL TANK HARNESS**

Fresh Water Tank	{ White* Grey w/Black (replaces Red tank lead) * Black w/Yellow (replaces Blue tank lead) *
Grey Water Tank	{ White* Green w/White (replaces Red tank lead) * Blue w/Black (replaces Blue tank lead) *
Black Water Tank	{ White* Red w/White (replaces Red tank lead) * Blue w/White (replaces Blue tank lead) *

\* - multiple applications for this color

# TYPICAL 110 VOLT WIRING DIAGRAM

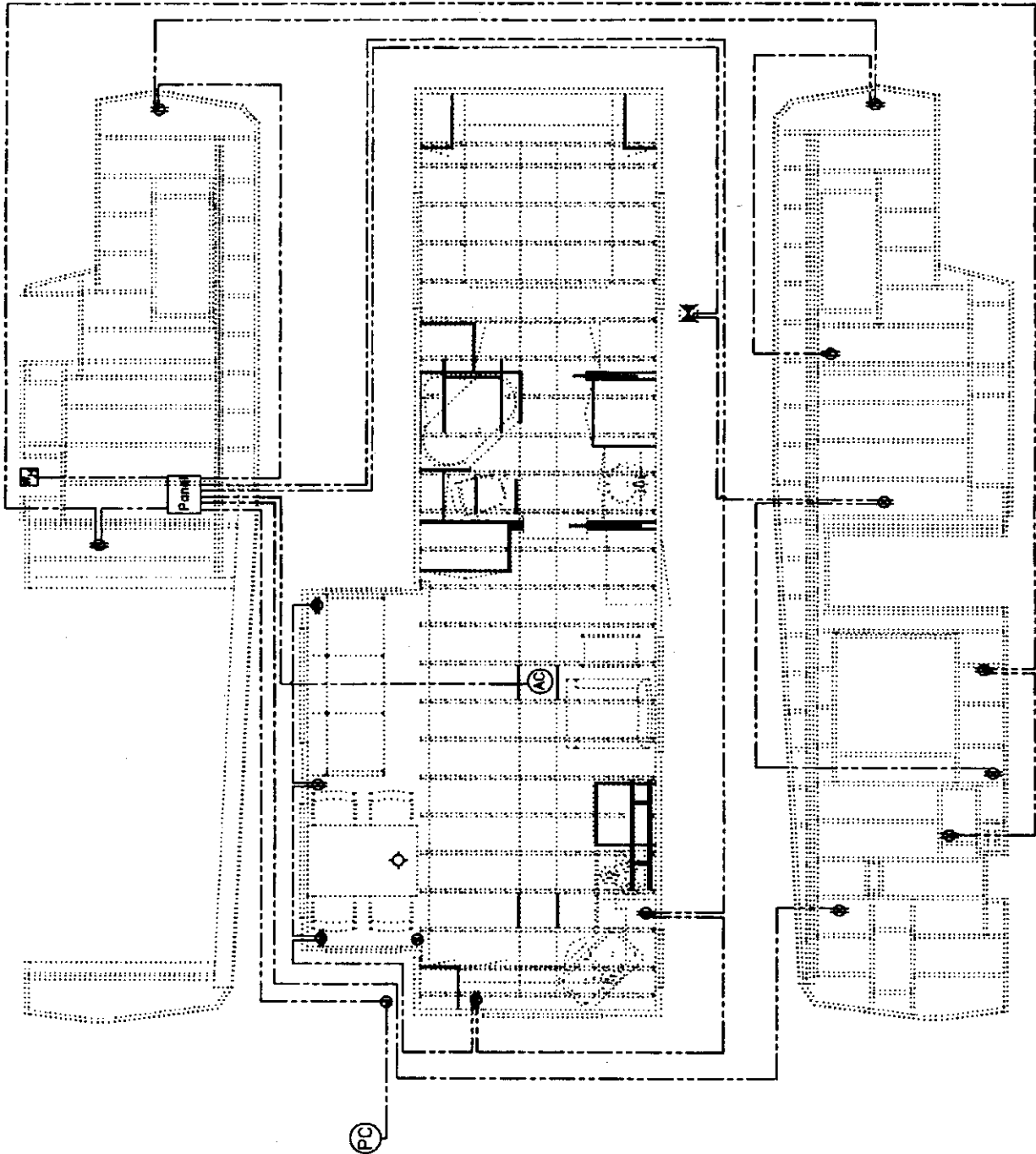

**WIRES ARE ROUTED ACROSS THE ROOF  
AND IN THE TOP SIDE WRAP OF THE UNIT.  
THE WIRES ARE ROUTED TO KEEP  
THE SHORTEST PRACTICAL LENGTH.**

# TYPICAL 12 VOLT WIRING DIAGRAM

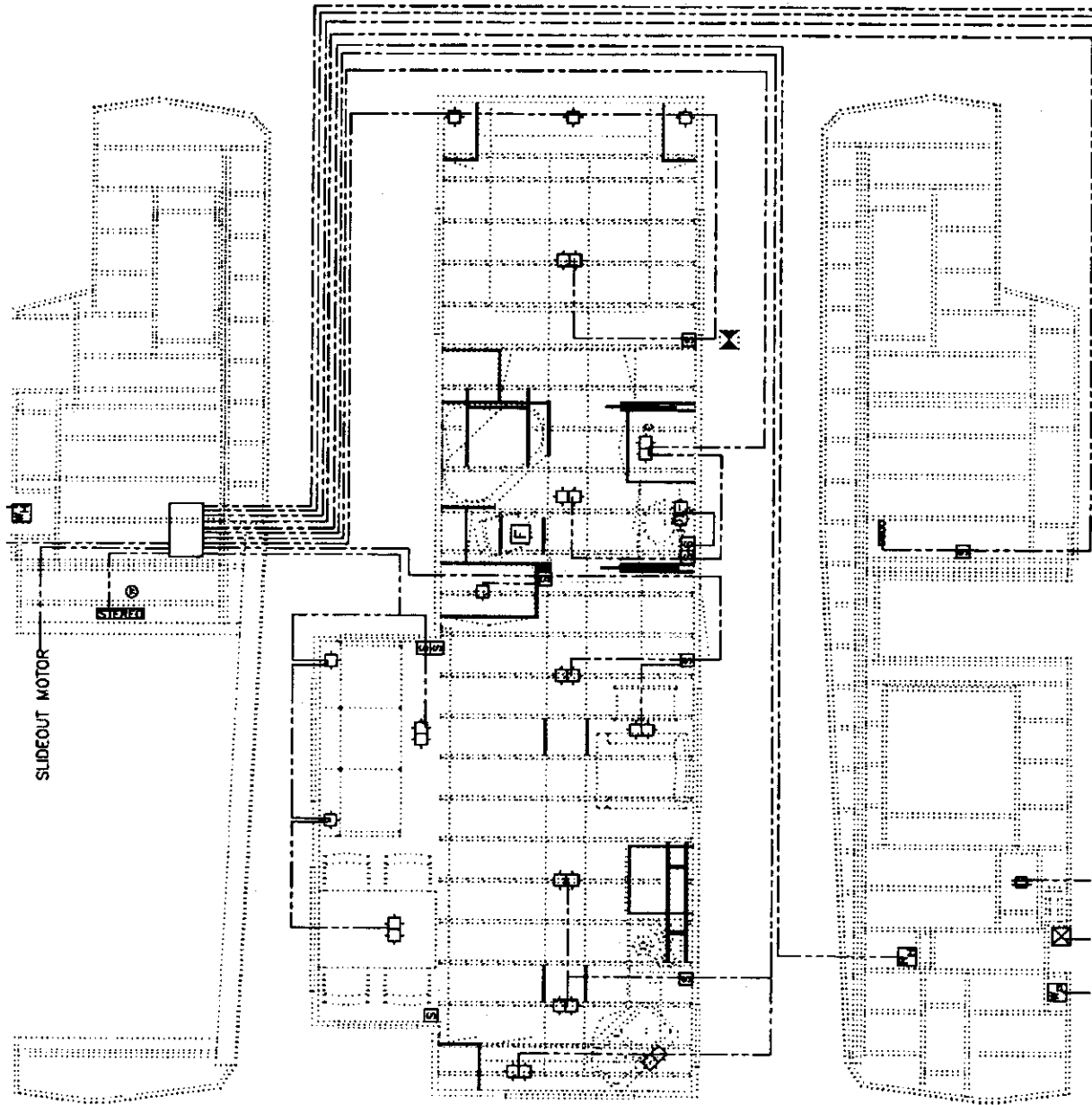

**WIRES ARE ROUTED ACROSS THE ROOF  
AND IN THE TOP SIDE WRAP OF THE UNIT.  
THE WIRES ARE ROUTED TO KEEP  
THE SHORTEST PRACTICAL LENGTH.**

# TV / VCR WIRING DIAGRAM

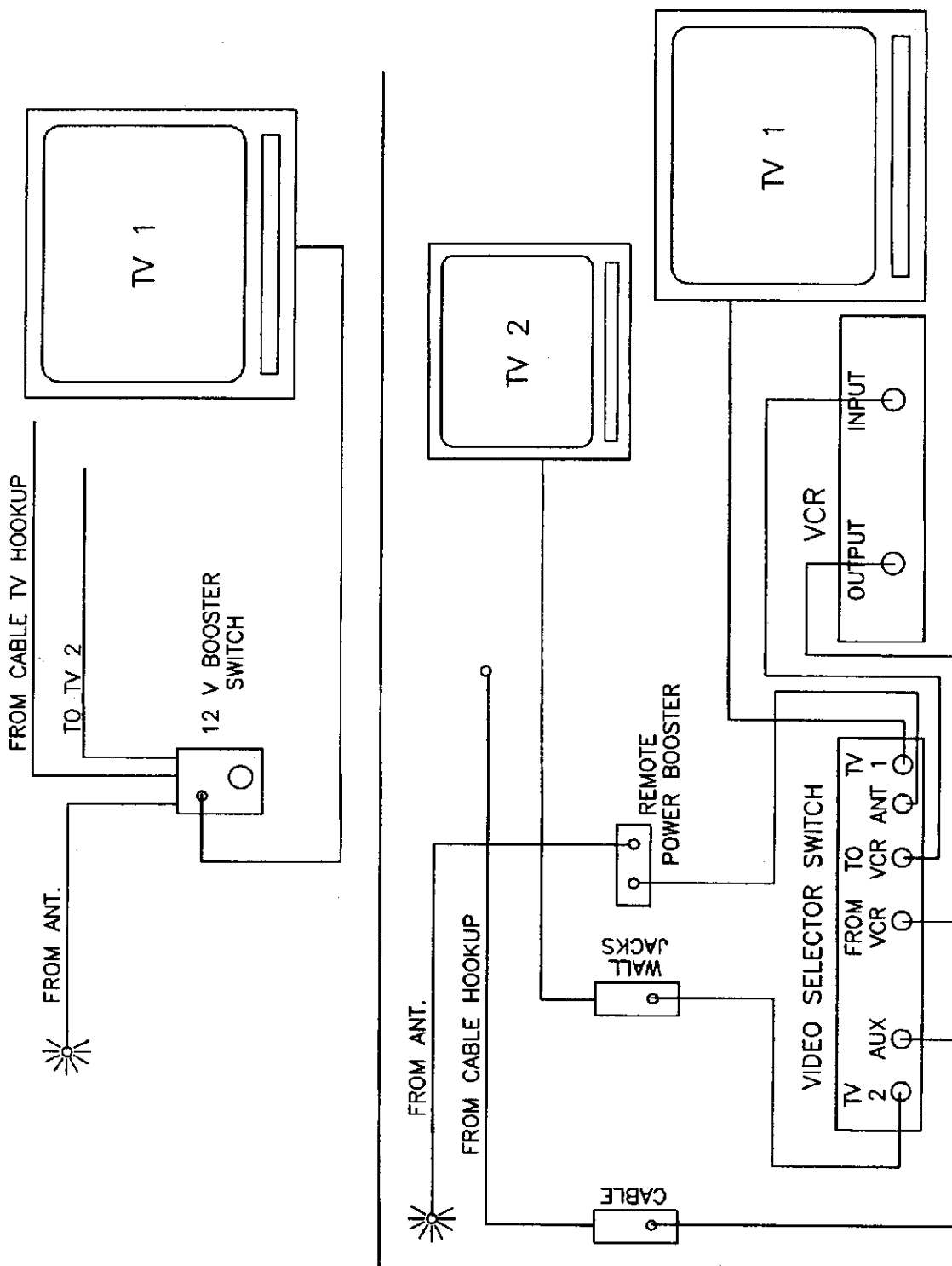

# TYPICAL FRESH WATER DIAGRAM

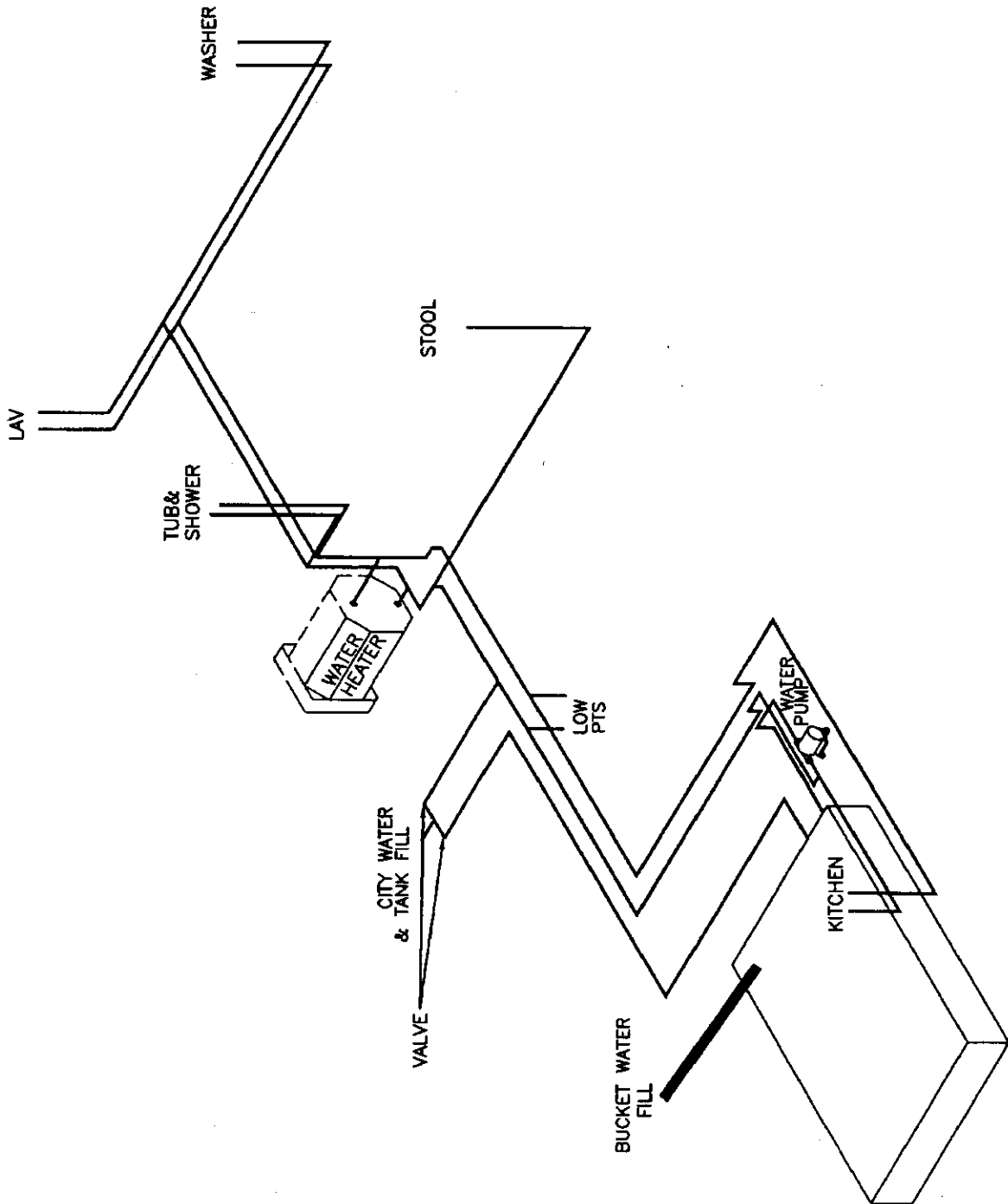



**NOTE:**

All materials used in the drainage system conform to ANSI A119.2 4-7.1

Drain grade set at 1/8 inch per foot minimum

Drain lines are supported at a maximum interval of 4 feet

Trap arm grade set at 1/4 inch per foot minimum (total slope does not exceed pipe diameter)

Maximum trap arm length is 54"

All traps are a minimum required size of 1 1/4" except the washer (if applicable) requires 1 1/2"

All traps are removable for use as a cleanout access

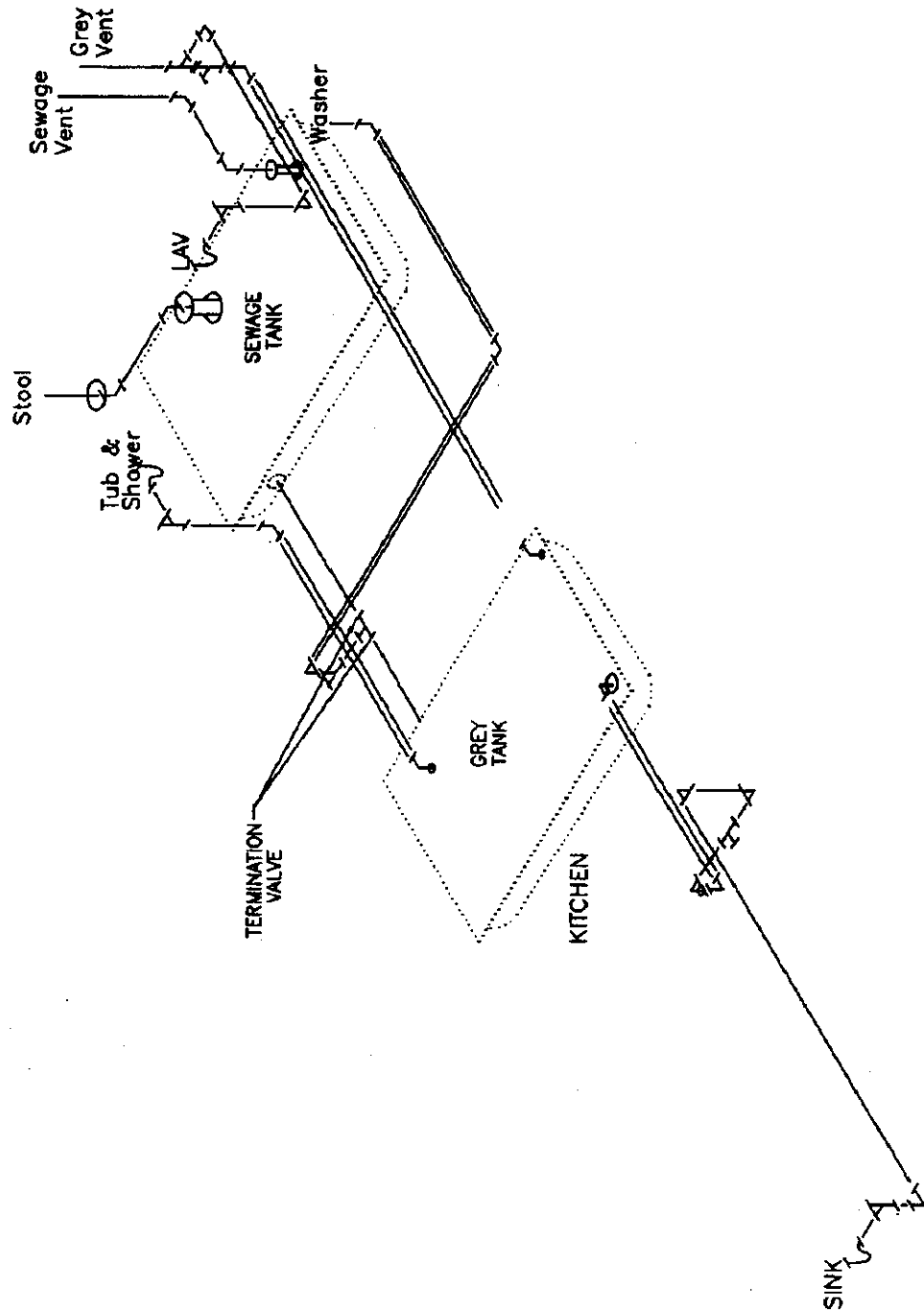

# TYPICAL DRAIN LINE DIAGRAM FOR UNITS OVER 34 FEET

**NOTE:**  
 ALL PIPE & FITTINGS ARE ABS SCHED. #40  
 DRAIN GRADE TO BE 1/8" PER FOOT  
 SUPPORT PIPE EVERY 4 FT MAX  
 ALL TRAP ARMS 54" MAX  
 ALL FIXTURES HAVE 1 1/4" P-TRAPS MINIMUM  
 ALL TANK HOOK-UPS ASE A DOUBLE LITTY UNLESS SPECIFIED OTHERWISE  
 BELOW FLOOR PLUMBING  
 SEE TYPICAL FOR WASHER INSTALLATION  
 BATH FLOOR LOCATION -----  
 P-TRAPS MAY BE USED AS CLEANOUTS

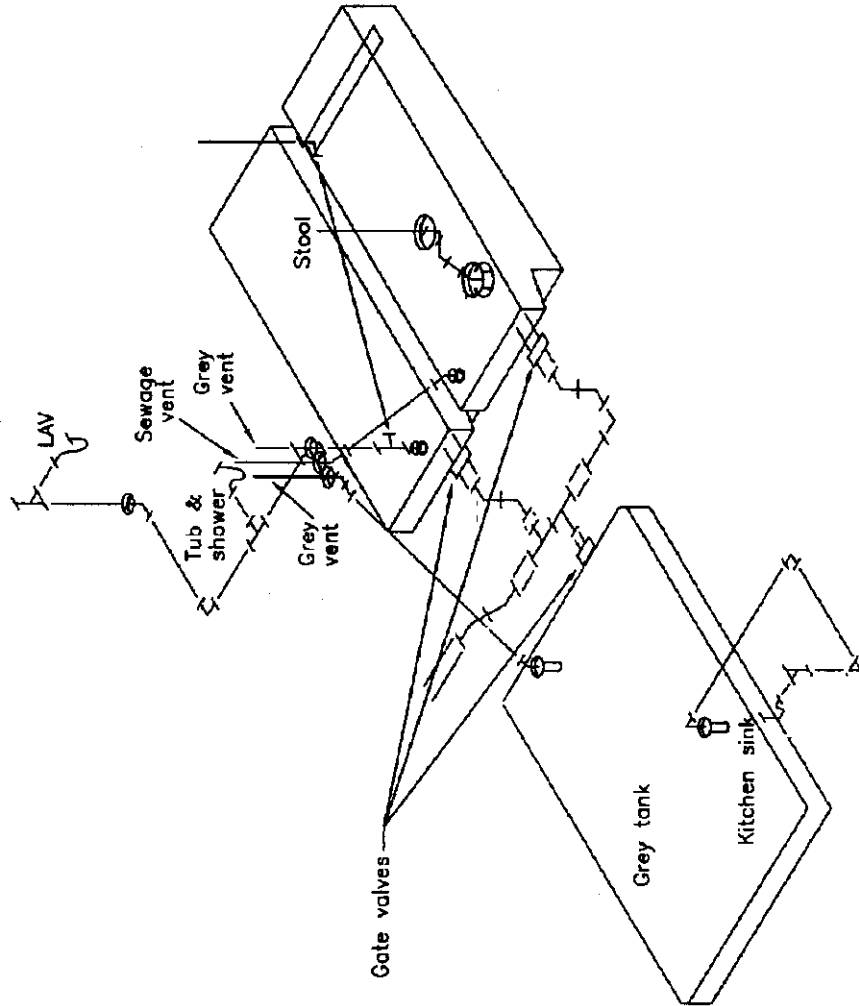

# SINGLE MOUNT SLIDE OUT MOTOR INSTALLATION DIAGRAM

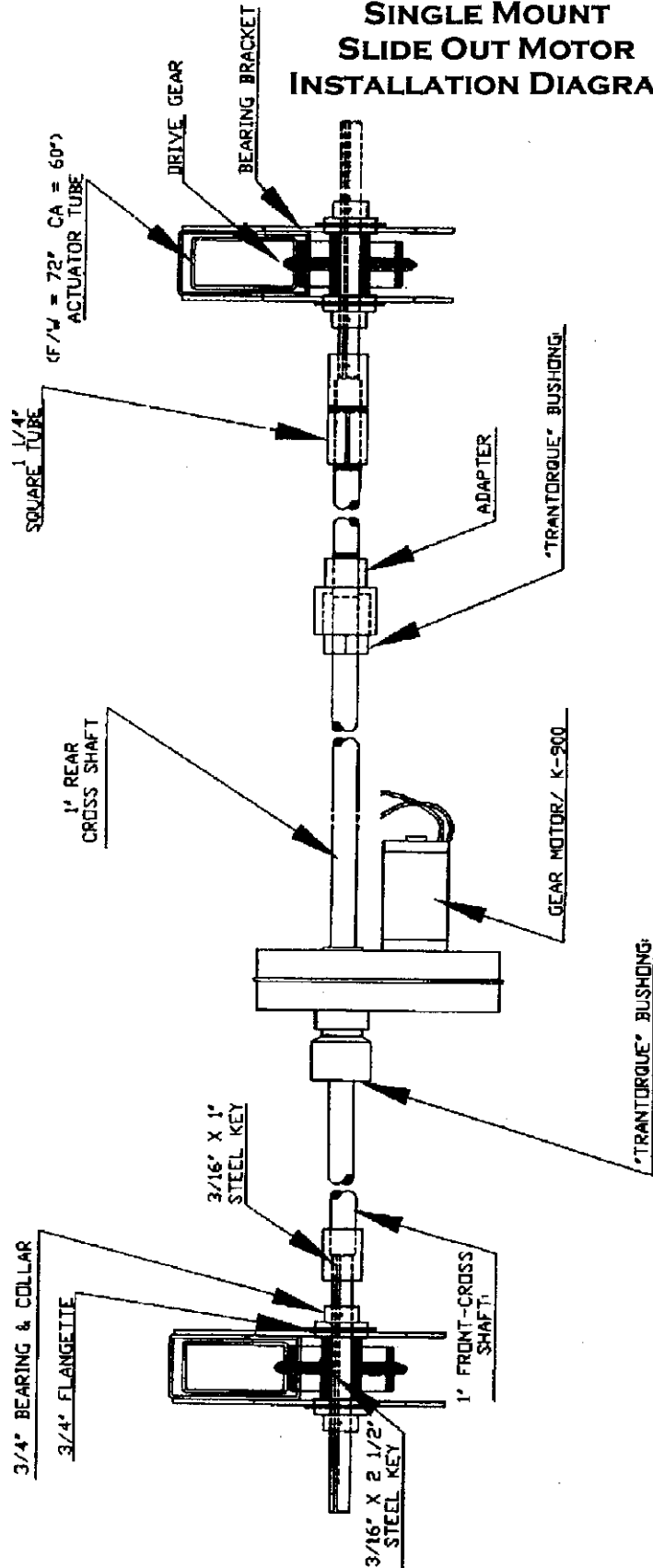

# 1999 LONDON AIRE FIFTH WHEEL

DESCRIPTION	ITEM #
Antenna, TV	QD 34841
Door, Main Entrance	ID 30129
Door, Furnace	QC 21868
Door, Refer Vent	QF 30100
Door, Water Heater	QG 24915
Faucet, Lav, Std	CM 24645
Faucet, Kitchen, Sgl Hdl	CM 24644
Faucet, Shower	CM 17200
Grab Handle, Acrylic, Door	NA 16229
Ladder	NA 30147
Light, Brake	EH 29685
Light, Scare	EH 10674
Recept, 12 Volt, White	EB 10641
Recept, 120 Volt, White	EB 10551

DESCRIPTION	ITEM #
Recept, GFCI	EB 10553
Register, Floor	QC 12292
Register, Ceiling	QC 22580
Roof Rack	NA 11820
Sink Cover	NA 25138
Skylight	IS 14607
Step, Kwikkee	ID 23708
Switch, 12 Volt, Double, White	EB 24810
Switch, 12 Volt, Single, White	EB 24809
Switch, 12 Volt, Triple, White	EB 24811
Switch, 120 Volt, White	EB 10543
Switch, 120 Volt, Brown	EB 10542
T-Stat, Dometic	QA 27782
T-Stat, FanTastic Vent	IS 01513