

NEW MAR

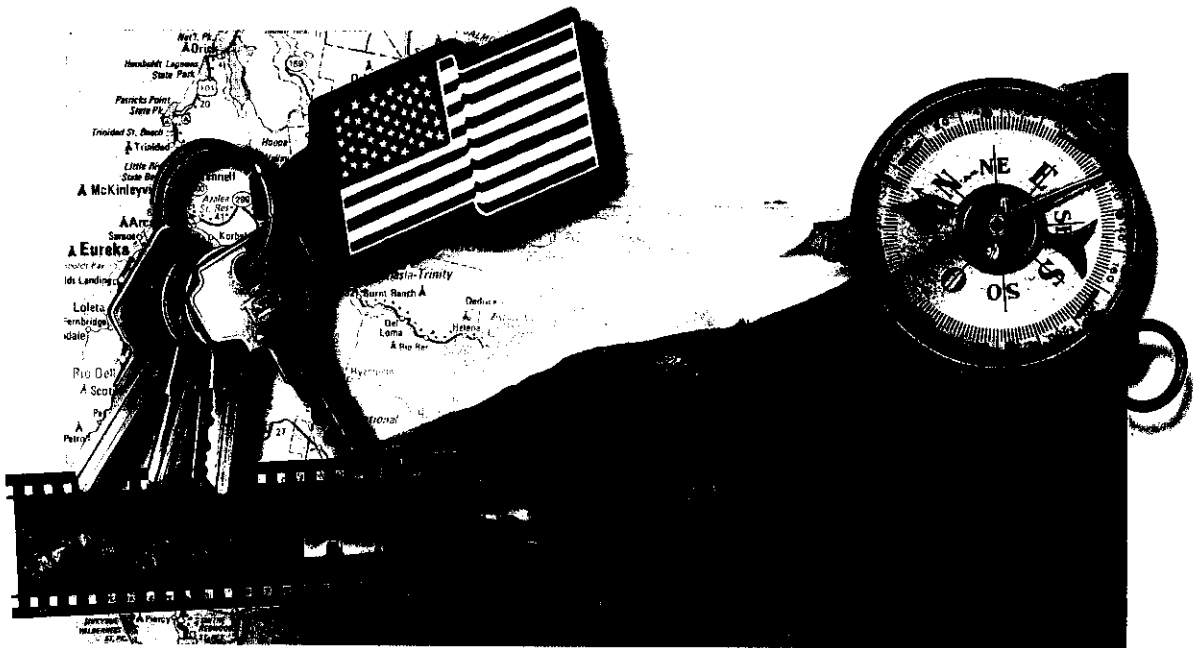

OWNER'S GUIDE

2000 Kountry Star

FIFTH WHEEL

NEWMAR CORPORATION OWNER'S GUIDE

Table of Contents

Chapter 1	General Information
Chapter 2	Towing & Safety Precautions
Chapter 3	Air Conditioning & Heating
Chapter 4	Appliances & Accessories
Chapter 5	Cabinets & Furniture
Chapter 6	Structure Features
Chapter 7	Electrical Features
Chapter 8	Slide Out Features
Chapter 9	Exterior Features
Chapter 10	Interior Features
Chapter 11	Plumbing & Bath Features
Chapter 12	Construction Features
Chapter 13	Windows, Awnings, Vents, & Doors
Chapter 14	Routine Maintenance
Chapter 15	Charts & Diagrams

Welcome to the exciting world of RV traveling and the growing family of recreational vehicle owners.

Congratulations on your purchase of a Newmar product. We sincerely thank you for choosing Newmar as your recreational vehicle. We trust this guide will help you to better understand and enjoy your new RV. We hope that you will enjoy many miles of traveling. Your new vehicle was built with care using today's technology and old world craftsmanship. We, at Newmar, strive to build vehicles that are safe, dependable, and comfortable to provide years of carefree, pleasant traveling.

This Owner's Guide, along with the Video Guide, should be kept in your vehicle for quick reference. Take time to get acquainted with your unit and how it operates. Carefully read both the instructions in this guide and the booklets supplied by the component manufacturers for important operation, safety, and maintenance information. Your dealer should be consulted should you have any questions. If your dealer is unable to answer the questions to your satisfaction he will refer you to our staff for help. Our customers are extremely important to us and we will make every effort necessary to ensure your satisfaction.

Again, thank you and welcome to our Newmar family.

Newmar Corporation

This guide, along with the Video Owner's Guide, has been provided by Newmar Corporation solely for the purpose of providing instructions about the operation and maintenance of this vehicle and its components. Nothing in this manual creates any warranty, either express or implied. The only warranty offered by Newmar Corporation is set forth in the written limited warranty that applies to this vehicle.

Instructions are included in this manual for operating some of the components that are standard on this vehicle. Instructions are also given for components that are options and may not appear on all vehicles. For more detailed information on components refer to the individual manufacturer's operating instructions contained in the Owner's Information Package.

The limited warranties issued by component manufacturers require periodic service and maintenance, and the owner's failure to provide this service and/or maintenance will result in the loss of warranty coverage. The owner should review the Newmar Corporation limited warranty and other manufacturers limited warranties of all components applicable to this vehicle. To activate the warranties on the components within your Newmar recreational vehicle, be sure to file the appropriate registration card with the component manufacturer as described with the individual instruction booklet.

Newmar Corporation has compiled the most current information available at the time of publication. If the components in your unit vary significantly from what is described within this manual, then consult the instructions provided by the component manufacturer found in the Owner's Package.

Throughout this guide, reference is made to the following terms: Warning, Caution, and Important. These terms indicate important information that must be understood and followed. The definitions of these terms are:

WARNING	
Emphasizes an area in which personal injury or even death could result from failure to follow instructions properly. Mechanical damage may also occur.	

CAUTION	
Failure to observe a caution can cause damage to the equipment or unit. Personal injury is unlikely.	

IMPORTANT	
Provides additional information to make a step easier or clearer.	

CHAPTER 1

GENERAL INFORMATION

Table of Contents



Delivery	1 - 1
Limited Warranty	1 - 2
Major Equipment Manufacturers	1 - 2
Warranty Service	1 - 3
Owner's Information Package	1 - 3
Customer Relations	1 - 3
Reporting Safety Defects	1 - 3
Specification Label	1 - 4
Recommended Service Centers	1 - 5

- of the factory installed components.
2. A customer walk through. This is done to familiarize the customer with the vehicle, its systems and components, and their operation.
 3. Delivery of the Owner's Information Package. This package contains the warranty cards and registrations for the vehicle and factory installed components that carry a separate warranty. The detailed operating and maintenance instructions on these components are also included in this package.
 4. Assisting the customer in completing the component registration forms, at the customer's request. To avoid loss of warranty coverage, the dealer should review the limited warranty provisions with the customer stressing the importance of filing warranty cards and registrations to the component's manufacturers within the prescribed time limit.
 5. Providing the customer with information regarding warranty and non-warranty work on the vehicle and its separately warranted components whether the customer is in or out of the area.

Customer Responsibilities

The customer is responsible for regular and proper maintenance of the vehicle. Properly maintaining your vehicle will prevent conditions arising from neglect that are not covered by your Newmar limited warranty. The maintenance guidelines in this manual and any other applicable manual should be followed. It is your responsibility and obligation to return the vehicle to an authorized dealer for repairs and service.

To assist you in avoiding problems with your vehicle, we recommend you do the following:

- a. Read the warranty. Go over it thoroughly with your dealer.
- b. Inspect the vehicle. Do not accept delivery until you have gone through the unit with the dealer. Newmar has provided a check list to be used during retail delivery. Check each item on the list and make sure the dealer does the same. Do not sign this checklist until you have done this.
NOTE: The sales literature versus actual specifics to the vehicle's measurements, weights, or quantities may vary.
- c. Ask questions about anything that you do not understand concerning your recreational vehicle.
- d. When taking delivery, set an appointment for adjustments. This appointment should be approximately two (2) weeks after you accept delivery.
- e. Responsible Use. Your vehicle is designed to be used for recreational or temporary living purposes. It is not designed to be used as a full-time residence or for commercial use. Commercial use means using as a business asset such as a mobile office or using the vehicle for lease/rental purposes.

Atwood (LP Detector & Water Heater)	815-877-5700
Audiovox (Radio)	800-688-3135
Carefree Awnings	800-621-2617
Dexter Axle	219-295-1900
Dometic, Duo Therm	800-544-4881
Exide Battery	800-537-9434
Fantastic Vents	800-521-0298
Flexsteel	319-556-7730
Gekotek (Monitor Panel)	714-738-3551
Goodyear Tires	800-227-1999
Kwikkee Products (Step)	800-736-9961
Magnadyne	219-262-4479
Magnavox Appliances	800-851-8885
Mor/Ryde Suspension	219-293-1581
Newmar Corporation	800-731-8300
Onan Generators	800-888-6626
Panasonic Appliances	888-433-6486
Sealand Toilets	800-321-9889
Sears Washer & Dryer	800-359-2000
Sharp	800-334-8251
Suburban Furnace	800-659-2138
Thetford Toilet	800-521-3032
Michigan Residents	313-769-6000
Todd Engineering	800-439-8633
U-Line Ice Maker	800-799-2547
Ventline (Rangehood)	219-848-4491
Wedgewood Range (Atwood)	815-877-5700
Wilsonart (Flooring)	800-433-3222
Winegard Antenna System	800-288-8094

Owner's Information Package

Included in this package are valuable documents about your vehicle and its components and systems. The Newmar Owner's Guide does not cover every possible detail of equipment, standard and/or option, installed on or in your vehicle. Consulting the booklets and instruction manuals in this package will help you safely operate, maintain, and troubleshoot these items.

Read all of the information and understand the safety and operating instructions included in the Owner's Information Package. To assure full warranty coverage, it is essential that all maintenance instructions are followed.

CUSTOMER RELATIONS

If you wish to schedule maintenance, service or to order parts, you should notify your local Authorized Newmar Service Center to set up an appointment. If you are unsure of the location of your closest Authorized Newmar Service Center, see the listing in the manual.

You may also write to:
Newmar Corporation
Warranty Department
P.O. Box 30
Nappanee, IN 46550-0030

REPORTING SAFETY DEFECTS

If you believe that your vehicle has a defect which could cause a crash or could cause injury or death, you should immediately inform the National Highway Traffic Safety Administration (NHTSA) in addition to notifying Newmar Corporation.

If NHTSA receives similar complaints, it may open an investigation, and if it finds that a safety defect exists in a group of vehicles, it may order a recall and remedy campaign. However, NHTSA cannot become involved in individual problems between you, your dealer, or Newmar.

To contact NHTSA, you may either call the Auto Safety Hot Line toll free at 1-800-424-9393 (or 366-0123 in Washington, D.C. area) or write to: NHTSA, U.S. Department of Transportation, Washington, DC 20590. You can also obtain other information about motor vehicle safety from the hotline.

1. The Newmar Serial Number
2. Last five digits Vehicle Identification Number (VIN)
3. Model Number of the Unit
4. Model Year of the Unit
5. Manufacturer, Model Number, and Serial Number of factory installed appliances

TOWABLE WEIGHT INFORMATION	
Newmar Serial Number	XXXXX
Model	XXXXXXXXXX
GVWR	XXXXX
UVW	XXXXX
NCC	XXXX
VIN #	XXXXXXXXXXXXXXXXXX

GVWR (Gross Vehicle Weight Rating) means the maximum permissible weight of this trailer. The GVWR is equal to or greater than the sum of the Unloaded Vehicle Weight plus the Net Carrying Capacity.

UVW (Unloaded Vehicle Weight) means the weight of this trailer as built at the factory. If applicable, it includes full generator fuel, engine oil and coolants. The UVW does not include cargo, fresh water, LP gas, or dealer installed accessories.

NCC (Net Carrying Capacity) means the maximum weight of all personal belongings, food, fresh water, LP gas, tools, dealer installed accessories, etc., that can be carried by this trailer. (NCC is equal to or less than GVWR minus UVW)

This trailer is capable of carrying up to XXXX gallons of fresh water (including water heater) for a total of XXXX pounds.
Reference: Weight of fresh water is 8.33 lbs/gal.

CONSULT OWNER'S MANUAL FOR SPECIFIC WEIGHING INSTRUCTIONS AND TOWING GUIDELINES.

Notes

REED CAMPER SALES

2405 JORDAN LANE
HUNTSVILLE AL 35816
(256) 830-5024 Fax (256) 830-4682

ALASKA**ALASKAN ADVENTURES RV CTR.**

918 EAST 73RD ST. P.O. BOX 230427
ANCHORAGE AK 99518
(907) 344-2072 Fax (907) 344-1608

ARIZONA**AMERICAN PRIDE RV CENTER**

2145 E. MAIN ST.
MESA AZ 85213-9100
(480) 644-1500 Fax (480) 644-0293

LA MESA RV CENTER

3631 E. FARNUM
TUSCON AZ 85706
(520) 745-4900 Fax (520) 294-7635

LA MESA RV CENTER

6651 GILA RIDGE ROAD
YUMA AZ 85364
(520) 344-4900 Fax (520) 341-9415

ARKANSAS**OUTDOOR LIVING CENTER**

HWY. 7 SOUTH
P.O. BOX 1081
RUSSELLVILLE AR 72801
(501) 968-7706 Fax (501) 968-4360

CALIFORNIA**ALPINE RECREATION SLS & SVC**

19380 MONTEREY ROAD
MORGAN HILL CA 95037
(408) 779-4511 Fax (408) 779-0754

BRAWLEYS

5933 N. MC HENRY AVE
P.O. BOX 2036
MANTECA CA 95336
(209) 521-0170 Fax (209) 521-9436

DAVE ALTMANS RV

1201 BALDWIN PARK BLVD.
BALDWIN PARK CA 9170
(626) 960-1884 Fax (626) 962-6906

DAVE ALTMANS RV

22020 RECREATION ROAD
CARSON CA 90745
(310) 518-6182 Fax (310) 513-0500

DAVE ALTMANS RV

1313 RV CENTER DRIVE
COLTON CA 92324
(909) 422-0311 Fax (909) 422-0450

ALPINE TRAVEL TRAILERS

2487 HIGHWAY 6 & 50
GRAND JUNCTION CO 81505
(970) 242-5898 Fax (970) 242-5898

J D L TRAILER SALES

2734 LAKE AVENUE
PUEBLO CO 81004
(719) 564-8056 Fax (719) 564-0306

MOUNTAIN STATES RV

14300 E. COLFAX AVENUE
AURORA CO 80011
(303) 360-0252 Fax (303) 363-9103

CONNECTICUT**DAVE'S RV CENTER**

2 INDUSTRIAL PLAZA ROAD
DANBURY CT 06810
(203) 730-1744 Fax (203) 730-1741

DELAWARE**SLICERS CAMPING TRAILERS**

773 S. DUPONT HWY.
NEW CASTLE DE 19720
(302) 836-4110 Fax (302) 836-4781

FLORIDA**DICK GORE'S RV WORLD**

14590 DUVAL PLACE WEST
JACKSONVILLE FL 32218
(904) 741-5100 Fax (904) 741-4905

INDEPENDENCE RV

12705 W. COLONIAL DRIVE
WINTER GARDEN FL 34787
(407) 877-7878 Fax (407) 877-3806

LAND YACHTS

1414 COMMERCE LANE
P.O. BOX 1840
JUPITER FL 33468
(561) 745-0242 Fax (561) 745-1725

LEISURE TYME RV

1490 HWY. 98 WEST
MARY ESTHER FL 32569
(850) 581-0880 Fax (850) 581-2300

LEISURE TYME RV

6428 PENSACOLA BLVD.
PENSACOLA FL 32505
(850) 476-6848 Fax (850) 474-6392

NORTH TRAIL RV CENTER

5270 ORANGE RIVER BLVD.
FORT MYERS FL 33905
(941) 693-8200 Fax (941) 693-9702

TRAVEL EASY RV INC

4299 HWY. 441 SOUTH
OKEECHOBEE FL 34974
(941) 467-0400 Fax (941) 467-9396

TRAVEL COUNTRY RV CTR. INC.

5343 MILL STORE RD.
LAKE PARK GA 31636
(912) 559-7902 Fax (912) 559-9021

IDAHO**AMERICAN WAY RV CENTER**

4033 CHINDEN BLVD.
BOISE ID 83714
(208) 345-6644 Fax (208) 345-5540

ILLINOIS**COLLIER RV CENTER**

3510 MERCHANDISE DRIVE
ROCKFORD IL 61109
(815) 874-7188 Fax (815) 874-9426

LARRY'S TRAILER SALES

HWY. 148 NORTH
P.O. BOX 98
ZEIGLER IL 62999
(618) 596-6414 Fax (618) 596-6344

OZARK COACH SALES

707 MACOMB ST. P.O. BOX 354
COLCHESTER IL 62326
(309) 776-3182 Fax (309) 776-3183

R & S SALES & SERVICE

218 S. LAKE OF THE WOODS ROAD
MAHOMET IL 61853
(217) 586-2055 Fax (217) 586-2382

INDIANA**ALL BRAND RV SERVICE**

2717-B OAKLAND AVE., P.O. BOX 1946
ELKHART IN 46517
(219) 294-2363 Fax (219) 522-2251

DONS CAMPER SALES

U.S. 41 S. BOX 373
BOSWELL IN 47921
(765) 869-5009 Fax (765) 869-5009

HART CITY RV SERVICE

2300 S. NAPPANEE STREET
ELKHART IN 46517
(219) 295-5793 Fax (219) 295-6190

INDY RV CENTER

457 KNIGHT DR.
P.O. Box 447
GREENWOOD IN 46142
(317) 881-0300 Fax (317) 881-0431

PREMIER RV

1400 LEISURE WAY
CLARKSVILLE IN 47129
(812) 284-1400 Fax (812) 283-3465

TERRY'S RV SALES & SERVICE

2900 E. CR 350 NORTH
MUNCIE IN 47303
(765) 289-9704 Fax (765) 289-9737

(515) 961-7405 Fax (515) 961-3674

WALKER TRAILER SALES INC.

HWY. 18 WEST, BOX 633
NORA SPRINGS IA 50458
(515) 749-2321 Fax (515) 749-2379

KANSAS

A & R

16685 ORCHARD LANE
STILWELL KS 66085
(913) 681-5446 Fax (913) 681-5446

HARPER CAMPERLAND

1200 E. 10TH, P.O. BOX 1993
GREAT BEND KS 67530
(316) 792-5170 Fax (316) 792-8466

HARPER CAMPERLAND

117 W. 14TH
HARPER KS 67058
(316) 896-2862 Fax (316) 896-2858

JAYHAWK CAMPER SALES

24105 W. 43RD
SHAWNEE KS 66226
(913) 422-5677 Fax (913) 422-7147

WILCOX HOMES & RV CENTER

835 NORTH EAST HWY. 24
TOPEKA KS 66608
(785) 357-5111 Fax (785) 232-1574

KENTUCKY

HALL ENTERPRISES

975 BEASLEY STREET
P.O. BOX 55038
LEXINGTON KY 40555
(606) 233-1777 Fax (606) 254-1073

SUMMIT RV SALES INC.

6917 US 60
ASHLAND, KY 41102
(606) 928-6795 Fax (606) 928-4102

YOUNGBLOOD RV CENTER INC.

2132 STATE ROUTE #45 NORTH
MAYFIELD KY 42066
(502) 247-8591 Fax (502) 247-0604

LOUISIANA

HOPE'S CAMPER CORNER INC.

6120 FRONTAGE ROAD
MONROE LA 71202
(318) 345-1691 Fax (318) 345-0224

JACKIE EDGAR RV CENTER

3018 N.E. EVANGELINE THRUWAY
P.O. BOX 90274
LAFAYETTE LA 70507-3425
(318) 232-1941 Fax (318) 232-1950

MILLER RV

12912 FLORIDA BLVD.
BATON ROUGE LA 70815
(504) 275-2940 Fax (504) 275-6807

BEECH GROVE TRAILER SALES

51439 M 40 NORTH
MARCELLUS MI 49067
(616) 646-7845 Fax (616) 646-2012

ERNIES RV SALES & SERVICE INC.

1066 STEPKE CT.
TRAVERSE CITY MI 49684
(231) 943-9111 Fax (231) 943-4441

GAYLORD RV SALES & SVC

271 WEST JOHNSON ROAD
GAYLORD MI 49735
(517) 732-6141 Fax (517) 731-2735

GENERAL RV CENTER

17277 RANCHO ROAD
BROWNSTOWN TWP MI 48192
(734) 284-5500 Fax (734) 284-5568

GENERAL TRAILER SALES

48135 GRATIOT AVE.
CHESTERFIELD MI 48051
(810) 949-3000 Fax (810) 949-4802

GENERAL TRAILER SALES

5300 HIGHLAND ROAD
WATERFORD MI 48327
(248) 674-0346 Fax (248) 674-3809

GENERAL TRAILER SALES

48500 12 MILE ROAD
WIXOM MI 48393
(248) 349-0900 Fax (248) 349-7965

HILLTOP RV SUPERSTORE

2905 N. LINCOLN ROAD
ESCANABA MI 49829
(906) 786-7986 Fax (906) 786-3421

INTERNATIONAL RV WORLD INC.

2717 E. DELTA ROAD
BAY CITY MI 48706
(517) 667-9840 Fax (517) 667-9843

KITSMILLER RV

1211 N. CEDAR
MASON MI 48854
(517) 694-7500 Fax (517) 694-3542

MIDWAY MOTOR HOMES

5590 S. DIVISION AVE.
GRAND RAPIDS MI 49548
(616) 534-9641 Fax (616) 534-6869

MODERN TRAILER SALES

3449 S. DIVISION AVE.
WYOMING MI 49548-2110
(616) 241-2925 Fax (616) 241-5451

RANCH RV SALES INC.

6825 HWY. M-68, P.O. BOX 158
ALANSON MI 49706
(231) 548-5443 Fax (231) 548-2202

TC RV INC.

705 N. US 31 SOUTH
TRAVERSE CITY MI 49684
(231) 943-4050 Fax (231) 943-4075

MISSISSIPPI

OLIVE BRANCH MS 38654
(601) 893-3040 Fax (601) 893-3044

RV REPAIR & SALES

4749 HWY. 80 WEST
JACKSON MS 39209
(601) 922-9425 Fax (601) 922-5153

MISSOURI

CAPETOWN R V SALES

I 55 & AIRPORT RD, P.O. BOX 1985
CAPE GIRARDEAU MO 63702
(573) 334-7152 Fax (573) 334-9059

COACHLIGHT RV SALES

5327 S. GARRISON AVE.
CARTHAGE MO 64836
(417) 358-7444 Fax (417) 358-0856

FRANK REED RV

HWY. 47 NORTH, P.O. BOX 212
ST. CLAIR MO 63077
(314) 583-2244 Fax (314) 583-2147

K C TRAILER SALES

11520 S. 71 HWY.
KANSAS CITY MO 64137
(816) 761-1393 Fax (816) 761-7722

THOMAS BILL CAMPER SALES

5217 N. LINDBERGH
ST. LOUIS MO 63044
(314) 731-2217 Fax (314) 731-0269

MONTANA

BRETZ RV & MARINE

RESERVE STREET AT I-90
4800 GRANT CREEK ROAD
MISSOULA MT 59808
(406) 541-4800 Fax (406) 541-4801

NEBRASKA

RICH & SONS CAMPER SALES

5112 S. ANTELOPE DRIVE
GRAND ISLAND NE 68803
(308) 384-2040 Fax (308) 384-2043

NEVADA

WHEELERS LAS VEGAS RV

13175 LAS VEGAS BLVD. SOUTH
LAS VEGAS NV 89124
(702) 896-9000 Fax (702) 896-4504

NEW HAMPSHIRE

C H DANA RV SALES & SVC

628 WOODSVILLE RD.
MONROE NH 03771-3328
(603) 638-2200 Fax (603) 638-2066

NEW MEXICO

ALOHA RV

11200 CENTRAL S.E., P.O. BOX 53250
ALBUQUERQUE NM 87123
(505) 298-8444 Fax (505) 275-7687

AMERICAN RV & MARINE

11810 CENTRAL S.E.
ALBUQUERQUE NM 87123
(505) 293-1983 Fax (505) 293-6991

AMERICAN RV & MARINE

200 NORTH TELSHORE BLVD
LAS CRUCES NM 88011
(505) 522-5512 Fax (505) 522-3781

NEW YORK

BALLARDS CAMPING CENTER

S - 5849 SOUTHWESTERN BLVD.
HAMBURG NY 14075
(716) 649-9654 Fax (716) 648-0340

FREEDOM RV OUTLET

103 SITTERLY ROAD
CLIFFTON PARK NY 12065
(518) 371-1289 Fax (518) 371-3001

JOURNEYTIME TRAILERS INC.

940 MIDDLE COUNTRY ROAD
SELDEN NY 11784
(631) 698-0055 Fax (631) 736-6622

SEVEN O'S

7917 DEVAUL ROAD
KIRKVILLE NY 13082
(315) 687-9342 Fax (315) 687-7992

WES TRAILER SALES

6166 ROUTE 25
WADING RIVER NY 11792
(631) 727-5852 Fax (631) 727-5396

WILKINS RV INC.

1099 ALMOND ROAD
HORNELL NY 14843
(607) 324-1313 Fax (607) 324-1082

WRATTEN TRAILER SALES

9209 ROUTE 11 SOUTH, P.O. BOX 5
ADAMS NY 13605
(315) 232-4535 Fax (315) 232-3445

NORTH CAROLINA

CAMPTOWN RV

12856 US HWY. 70 WEST
CLAYTON NC 27520
(919) 553-7277 Fax (919) 553-2716

HOWARD RV CENTER

6811 MARKET STREET
WILMINGTON NC 28405
(910) 791-5371 Fax (910) 392-0672

OHIO

AMOS MOTOR & RV

109 S MAIN STREET, P.O. BOX 555
BRADNER OH 43406
(419) 288-2700 Fax (419) 288-3273

ARBOGAST RV DEPOT

3540 SOUTH COUNTY ROAD 25A
P.O. BOX 219
TROY OH 45373
(937) 335-0068 Fax (937) 335-0471

BEGGS MOTOR HOMES

11197 CLEVELAND AVE NORTH WEST
P.O. BOX 545
UNIONTOWN OH 44685
(330) 499-9755 Fax (330) 499-6002

COLERAIN TRAILER CENTER

3491 STRUBLE ROAD
CINCINNATI OH 45251
(513) 923-3600 Fax (513) 245-5145

FARBER MOTORS

5858 SCARBOROUGH BLVD.
COLUMBUS OH 43232
(614) 864-7878 Fax (614) 864-7899

OKLAHOMA

DAVE'S CLAREMORE RV

1400 S. LYNN RIGGS
CLAREMORE OK 74017
(918) 341-0114 Fax (918) 341-8936

DEAN'S RV SUPERSTORE INC

9955 EAST 21ST
TULSA OK 74129
(918) 664-3333 Fax (918) 664-8643

LEE'S R V CITY

13111 N. BROADWAY EXT.
P.O. BOX 6250
EDMOND OK 73083-6250
(405) 936-9300 Fax (405) 936-9323

LEWIS TRAVEL TRAILER SALES

11518 E. 66TH ST. P.O. BOX 104
OWASSO OK 74055
(918) 272-1353 Fax (918) 272-5451

OREGON

ALL SEASONS RV & MARINE

63195 JAMISON ST., P.O. BOX 5699
BEND OR 97708
(541) 382-5009 Fax (541) 382-8510

AL'S TRAILER SALES OF SALEM

4843 PORTLAND ROAD NORTH EAST
SALEM OR 97305
(503) 393-3365 Fax (503) 393-1525

HILLSBORO OR 97123

(503) 649-2141 Fax (503) 642-9579

OLINGER

9401 S. E. 82ND
PORTLAND OR 97266
(503) 771-2121 Fax (503) 771-4638

TRIPLE A RV CENTER INC.

938 CHEVY WAY
MEDFORD OR 97504
(541) 772-1938 Fax (541) 779-1460

PENNSYLVANIA

ANSLEY RV

1280 ROUTE 764, P.O. BOX 239
DUNCANSVILLE PA 16635
(814) 695 9817 Fax (814) 695-9814

COUNCIL CUP TRAILER SALES

ROUTE 239
WAPWALLOPEN PA 18660
(570) 379-3751 Fax (570) 379-2913

HAROLD'S RV CENTER

7514 BETH BATH PIKE
BATH PA 18014
(610) 837-9880 Fax (610) 837-9473

R D KENNEDY SALES & SERVICE

1394 OLD YORK ROAD
DILLSBURG, PA 17019
(717) 432-9741 Fax (717) 432-1400

ROLLING WHEELS RV

2314 LYCOMING CREEK ROAD
WILLIAMSPORT PA 17701
(570) 322-1894 Fax (570) 322-1902

RHODE ISLAND

ARLINGTON RV SUPER CENTER

966 QUAKER LANE
EAST GREENWICH RI 02818
(401) 884-7550 Fax (401) 885-4566

SOUTH CAROLINA

TONY'S RV PARTS & SERVICE INC.

130 POND BRANCH RD
LEXINGTON SC 29073
(803) 894-3071 Fax (803) 894-5385

SOUTH DAKOTA

SCHAAP'S TRAVELAND

3100 W. RUSSELL
SIOUX FALLS SD 57107
(605) 332-6241 Fax (605) 332-5422

TENNESSEE

AMERICAN RV CENTERS

4050 N. THOMAS
MEMPHIS TN 38127
(901) 353-1999 Fax (901) 353-1888

HILLTOP TRAVEL TRAILERS

850 W. RED OAK ROAD, P.O. BOX 723
 RED OAK TX 75154
 (972) 299-5074 Fax (972) 617-7065

PROFESSIONAL SALES

1809 JOHN MCCAIN RD., P.O. BOX 1018
 COLLEYVILLE TX 76034
 (817) 488-9542 Fax (817) 488-1523

RON HOOVER CO.

29277 I.H. 10 WEST
 BOERNE TX 78006
 (830) 755-2252 Fax (830) 755-8644

RON HOOVER CO.

5029 COLUMBIA STREET
 CORPUS CHRISTI TX 78416
 (361) 854-5383 Fax (361) 851-9578

RON HOOVER CO.

16465 KATY FREEWAY
 HOUSTON, TX 77094
 (281) 829-1560 Fax (281) 829-9562

RON HOOVER CO.

1510 W. MARKET ST., P.O. BOX 747
 ROCKPORT TX 78382
 (361) 729-9695 Fax (361) 729-9698

VOGT MOTOR HOMES

5624 AIRPORT FREEWAY
 FORT WORTH TX 76117
 (817) 831-4222 Fax (817) 838-5574

UTAH**BLAINE JENSEN & SONS RV CTRS.**

780 N. 900 WEST
 KAYSVILLE UT 84037
 (801) 544-4298 Fax (801) 544-3685

ESQUIRE RV

1285 W. 600 SOUTH
 VERNAL UT 84078
 (435) 789-4859 Fax (435) 781-9946

VERMONT**PETE'S RV CENTER**

4016 WILLISTON ROAD
 S. BURLINGTON VT 05403
 (802) 864-9350 Fax (802) 862-4806

VIRGINIA**CAMP - A - RAMA**

1107 N. GEORGE WASHINGTON HWY.
 CHESAPEAKE VA 23323
 (757) 487-8113 Fax (757) 485-2736

KOOGLER SALES & SERVICE

ROUTE 2, BOX 193
 FISHERSVILLE VA 22939
 (540) 942-5556 Fax (540) 943-0853

MILESTONE RV CENTER

6722 EAST SPRAGUE AVE.
 SPOKANE WA 99212
 (509) 924-6446 Fax (509) 891-4131

TVETEN RV COMPANY

7700 PACIFIC HWY. EAST
 MILTON WA 98354
 (253) 922-7770 Fax (253) 922-8742

WEST VIRGINIA**BRAND TRAILER SALES**

2045 FAIRMONT AVE.
 FAIRMONT WV 26554
 (304) 366-7104 Fax (304) 363-9345

SETZER'S WORLD OF CAMPING

5840 DAVIS CREEK ROAD
 BARBOURSVILLE WV 25504
 (304) 736-5287 Fax (304) 736-5992

WISCONSIN**FINNEGANS RV**

205 PARK AVE.
 BELOIT WI 53511
 (608) 365-2306 Fax (608) 365-3569

HORN'S SALES & SERVICE

8120 S. FRONTAGE ROAD
 SHEBOYGAN WI 53081
 (920) 564-2381 Fax (920) 564-2385

WYOMING**EASTSIDE MOTORS & RV'S INC.**

1200 E. SECOND ST., P.O. BOX 3254
 GILLETTE WY 82717
 (307) 686-1435 Fax (307) 682-1435

ALBERTA**MAJESTIC RV WORLD**

2777 SUNRIDGE BLVD. NORTH EAST
 CALGARY AB T1Y 3C2
 (403) 291-1203 Fax (403) 291-9561

VELLNER LEISURE PRODUCTS

1890 49 AVENUE
 RED DEER AB T4R 2N7
 (403) 343-1464 Fax (403) 340-8135

BRITISH COLUMBIA**JIM BOTTOMLEY'S RV WORLD**

1834 BYLAND ROAD
 KELOWNA BC V1Z 3E5
 (250) 769-3688 Fax (403) 769-3899

MIDTOWN RV LTD.

64 INDUSTRIAL AVE. WEST
 PENTICTON BC V2A 6M2
 (250) 492-5705 Fax (250) 492-0430

WALT'S TRAILER SALES LTD.

5195 PORTAGE AVE.
 HEADINGLY MB R4H 1E1
 (204) 837-8388 Fax (204) 831-8674

NEW BRUNSWICK**CAMPERS ALLEY LTD.**

11 RUE BOURQUE ST., P.O. BOX 929
 BOUCTOUCHE NB E0A 1G0
 (506) 743-8404 Fax (506) 743-6855

ONTARIO**1000 ISLANDS RV CENTRE**

409 CR #2, R.R. #2
 GANANOQUE ON K7G 2V4
 (613) 382-4400 Fax (613) 382-2466

FRONTIER RV

4131 HWY 115-35, 984 FINLEY AVE.
 ORONO ON L0B 1M0
 (905) 983-8000 Fax (905) 983-5746

WILLIAM PATTERSON RV SALES

8359 PIONEER LINE, R.R. # 1
 DUTTON ON N0L 1J0
 (519) 762-2125 Fax (519) 762-3386

QUEBEC**RAYMOND LEBLANC**

1275 DES LAURENTIDES BLVD.
 VIMONT LAVAL PQ H7M 2Y2
 (450) 663-7941 Fax (450) 663-2213

SASKATCHEWAN**D J'S RV CENTRE LTD.**

THATCHER DRIVE EAST & #1 HWY.
 P.O. BOX 308
 MOOSE JAW SK S6H 4N9
 (306) 694-6048 Fax (306) 694-1221

2/7/00

Table of Contents

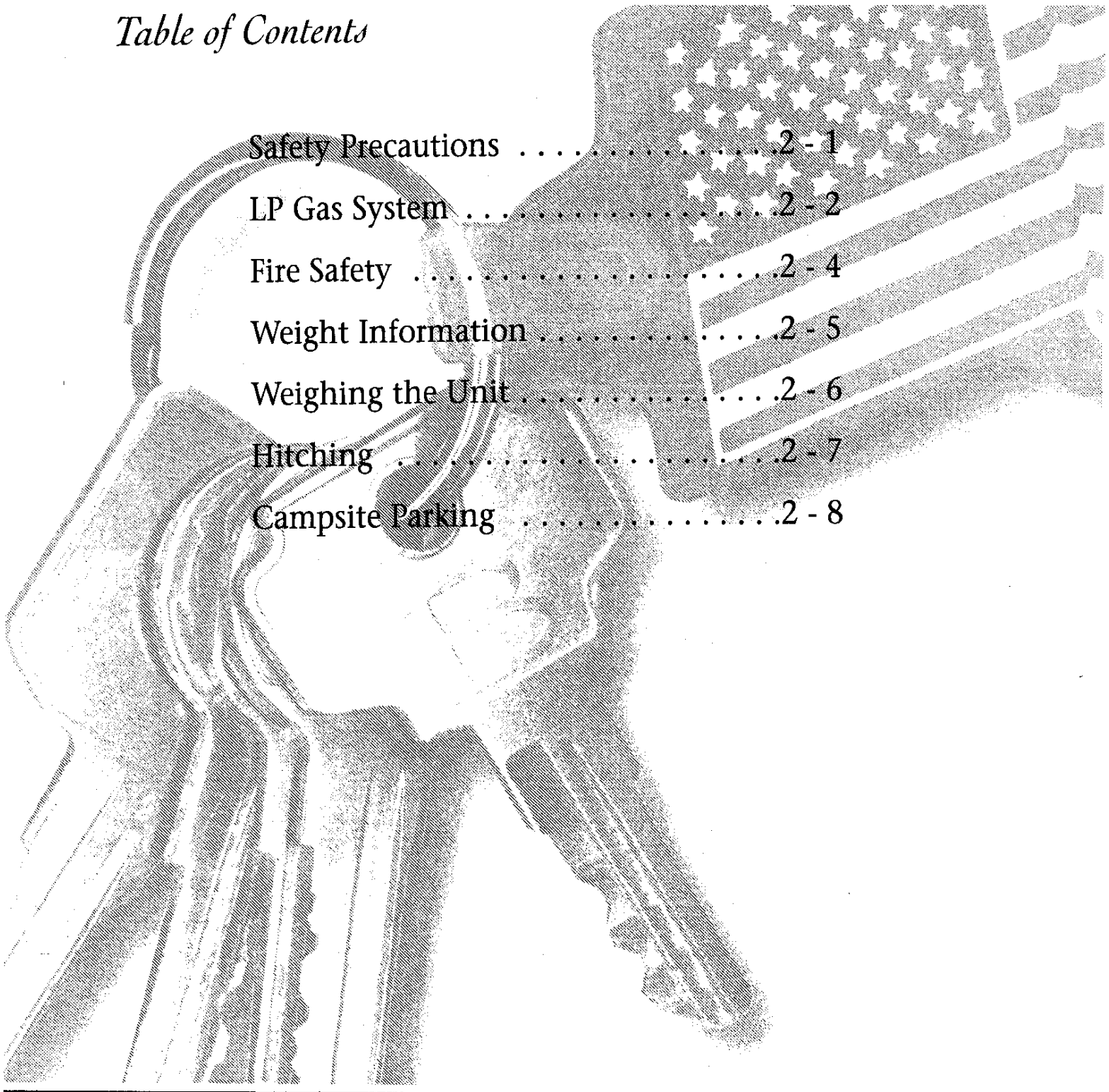

Safety Precautions	2 - 1
LP Gas System	2 - 2
Fire Safety	2 - 4
Weight Information	2 - 5
Weighing the Unit	2 - 6
Hitching	2 - 7
Campsite Parking	2 - 8

regulator yourself. Have an authorized service technician make any necessary adjustments. We recommend that you have the LP gas system checked by an authorized service technician at least once a year, and after every extended trip. Although the manufacturer and dealer test carefully for leakage, travel vibrations could loosen fittings. Leaks can be easily found by applying leak detector solutions at the connections. If leak detector solution is not available, a soapy water solution made with dish soap can be used. Tightening the fitting usually stops any leaks. If this does not work, shut off the main gas valve at the tank and immediately consult an authorized technician for repairs. If a leak is suspected, the identifying odor smells similar to rotten eggs (sulfur). Never test for a leak by lighting a match or have an open flame where you suspect leaking gas.

WARNING

Shut off the main gas valve at the tank when the camping vehicle is not in use. Also, shut off the valve when refueling to avoid potential danger from pilot lights igniting fuel fumes. Some appliances, such as the refrigerator, water heater, and furnace, have DSI (direct spark ignition) boards so it is important that you turn the appliances off when the LP gas is off. The ignition in the appliances will continue to spark even if there is no LP gas available.

LP Regulator

The regulator acts as the heart for the LP gas system. The LP gas in the tank is under high pressure. The regulator reduces the pressure of this gas so that it is safe to use with the various appliances in your unit. If corrosion is noticed, contact a qualified LP gas service technician. Do not adjust the regulator. It is factory preset. Adjustments are to be made by a qualified LP service technician using specialized equipment.

LP gas regulators must always be installed with the diaphragm vent facing downward. Regulators that are not in compartments have been equipped with a protective cover. Make sure that the regulator vent faces downward and that the cover is kept in place to minimize the vent blockage that could result in excessive gas pressure causing fire or explosion.

LP Distribution Lines

The primary manifold is a black steel pipe running the length of your unit. Most secondary lines leading to gas appliances are made of copper tubing with flare fittings. If any of the gas lines rupture, do not attempt to splice them. Always run a new line. We recommend gas distribution work be performed by an authorized service technician. The main valve at the LP tank must be closed when removing or servicing any gas appliance. This will prevent dangerous gas leakage that could result in an explosion and possibly serious injury. If a leak is suspected, have the systems inspected and repaired by a qualified service technician.

Precautions & Recommendations

- Inspect the LP fill valve for foreign materials before refueling.
- Shut the pilot lights off prior to refueling LP gas tanks.
- Never check for gas leaks with an open flame (match, etc.).
- Gas lines should be visually inspected periodically.
- Have the gas system inspected yearly and before and after extended trips.
- The gas system should be inspected and repaired by qualified technicians only.

WARNING

The LP system in your recreational vehicle is designed for liquefied petroleum gas only. Never attempt to connect natural gas or butane gas in this system.

FIRE SAFETY

The possibility of fire exists in all areas of life, and the recreational life-style is no exception. Recreational vehicles are complex machines. They are made up of many materials, some of which are flammable. Like most hazards, the possibility of fire can be minimized, if not totally eliminated. This is done by recognizing the danger and practicing common sense safety and maintenance habits. For safety reasons, your unit is furnished with both a fire extinguisher and a smoke alarm.

Fire Extinguisher

The fire extinguisher is rated for Class B (grease, gasoline, diesel fuel, flammable liquids) and Class C (electrical) fires. These are the most common types of fires in vehicles. Read the operator's manual and the instructions on the fire extinguisher. Be sure to know how and when to use the extinguisher and where it is located.

Fire extinguishers are mechanical, pressurized devices. Care must be exercised when they are handled. They must be maintained as the operator's manual instructs for proper and safe operation. The extinguisher should be inspected at least once a month. More frequent inspections may be required if the extinguisher is exposed to the weather or to possible tampering. Do not test the extinguisher by partially discharging. Doing this will cause a loss of pressure.

If a fire occurs in the vehicle, evacuate the vehicle as quickly and as safely as possible. Consider the cause and the severity of the fire and the risk involved before trying to extinguish it. If the fire is major or fuel fed, move away from and stand clear of the vehicle and wait for emergency assistance to arrive.

Smoke Detector

The battery powered smoke detector is mounted on the ceiling in the living area of the unit. Read the operating instructions for details on the testing and care for this important safety device. Test the smoke detector after the unit has been in storage, before each trip, and at least once a week during use. The detector should never be disabled because of nuisance or false alarm from cooking smoke or a dusty furnace. Ventilate the unit with fresh air and the alarm will shut off. Never disconnect or remove the battery from the smoke alarm. The battery should be replaced once a year or when the low battery signal sounds.

Emergency Exit Window

In the bedroom or slide out of the unit, there may be an emergency exit (egress) window. This window is designed to be used as an additional exit in emergency situations. It can be easily identified by the red handle and the red "EXIT" label. To open the egress window, lift the handle and push outward on the window. The window can be closed by pulling the window shut and lowering the handle in the down or locked position.

WEIGHT INFORMATION

Below is a sample of a weight information label which may appear in your unit.

TOWABLE WEIGHT INFORMATION			
Newmar Serial Number	XXXXX	VIN #	XXXXXXXXXXXXXXXXXXXX
Model	XXXXXXXXXX		
GVWR	XXXXX		
UVW	XXXXX		
NCC	XXXX		

GVWR (Gross Vehicle Weight Rating) means the maximum permissible weight of this trailer. The GVWR is equal to or greater than the sum of the Unloaded Vehicle Weight plus the Net Carrying Capacity.

UVW (Unloaded Vehicle Weight) means the weight of this trailer as built at the factory. If applicable, it includes full generator fuel, engine oil and coolants. The UVW does not include cargo, fresh water, LP gas, or dealer installed accessories.

NCC (Net Carrying Capacity) means the maximum weight of all personal belongings, food, fresh water, LP gas, tools, dealer installed accessories, etc., that can be carried by this trailer. (NCC is equal to or less than GVWR minus UVW)

This trailer is capable of carrying up to 110 gallons of fresh water (including water heater) for a total of 916.3 pounds.
Reference: Weight of fresh water is 8.33 lbs/gal.

CONSULT OWNER'S MANUAL FOR SPECIFIC WEIGHING INSTRUCTIONS AND TOWING GUIDELINES.

Weighing the Unit

The following definitions are given to help in communications of issues of weight and your unit.

- GAWR:** Gross Axle Weight Rating means the maximum permissible weight for an axle. This takes into consideration the weakest link in the tire, wheel, brakes, hubs, axle, springs, and attaching parts. For example, if the axle is rated at 6,000 pounds and the tires are rated at 2,540 pounds each, the maximum GAWR would be 5,080 pounds.
- GVWR:** Gross Vehicle Weight Rating means the maximum permissible weight of this trailer. The GVWR is equal to or greater than the sum of the Unloaded Vehicle Weight plus the Net Carrying Capacity.
- UVW:** Unloaded Vehicle Weight means the weight of the trailer as built at the factory. If applicable, it includes full generator fuel, engine oil, and coolants. The UVW does not include cargo, fresh water, LP gas, or dealer installed accessories.
- NCC:** Net Carrying Capacity means the maximum weight of all personal belongings, food, fresh water, waste water, LP gas, tools, dealer installed accessories, etc., that can be carried by the trailer. NCC is equal to or less than the GVWR minus the UVW.
- GVW:** Gross Vehicle Weight is the weight of the unit with all items and supplies that are loaded into the unit at any point in time.

To assure the accuracy of your weights be sure the unit is always level during weighing.

The unit has been built to comply with the component suppliers recommended limits and give you a realistic NCC. When loading the unit, distribute the items so that not all of the weight is added to one area of the unit. If you have questions as to what the weight of the unit is after it has been loaded, take the unit to a drive on scale, or use individual wheel scales and verify that the weights are within the limits of those specified for the unit. When weighing the unit follow these instructions. Failure to follow these instructions may give an erroneous weight reading.

NOTE: The sales literature may give approximates or standards. Each individual unit may weigh differently based on the factory and/or dealer options added.

Notes

Fifth Wheels

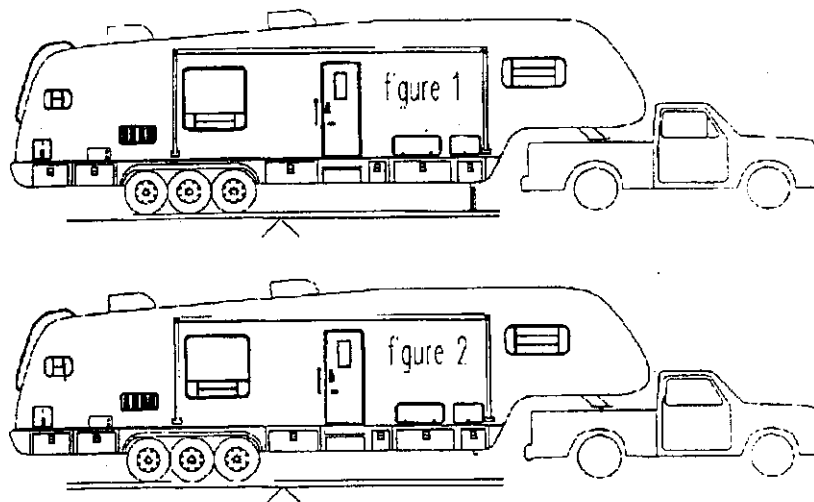

1. Pull the unit onto the scales shown in Fig. 1. This is the total weight of the unit. To do this, put the front jacks down far enough to take all of the weight off of the tow vehicle and onto the scales. Make sure that only the trailer is on the scales. Record the weight. This is the GVW and should not exceed the GVWR supplied by Newmar for the unit.
2. Hook up to the unit and be sure, again, that there is no part of the tow vehicle on the scales as shown in Fig 2. Weigh the unit with only the trailer tires on the scales. Record the weight. This is the total weight on the axles. When this amount is subtracted from the GVW (first reading), the difference is the hitch weight. To achieve the approximate weight on each axle, divide the weight from Fig. 2 by the number of axles. This amount should not exceed the GAWR of the unit. For example 9,360 pounds with 2 axles is 4,680 pounds per axle or approximately 2,340 pounds per tire.

HITCHING

Fifth Wheels

IMPORTANT:

Your fifth wheel is equipped with electric trailer brakes. Make sure the proper brake controls are installed and in working order before traveling.

Hooking the fifth wheel will become quite simple after a little practice. Follow the steps listed below.

1. Adjust the fifth wheel jacks until the trailer is at the height level for hooking to the tow vehicle.
2. Place wheel chocks behind the wheels of the coach.

3. Release the fifth wheel lock handle.
4. Align the tow vehicle so the fifth wheel will accept the kingpin.
5. Back the tow vehicle slowly into the fifth wheel until the kingpin engages in the fifth wheel lock, automatically locking.
6. Verify that the lock is closed.
7. Connect the electrical pigtail between the fifth wheel and the tow vehicle.
8. Connect the break away switch line. Be sure the break away switch cable is not attached to any part of the tow vehicle hitch assembly. Make sure there is enough slack in the break-a-way cable to allow for turning.
9. Adjust the mirrors on the tow vehicle.
10. Check all of the lights on the fifth wheel and the tow vehicle (running lights, brake and tail lights, turn signal lights, and back up lights).
11. Pick up and store the wheel chocks.
12. Check the inside of the coach to verify that everything is stored properly, vents are closed, all of the doors and drawers are shut, and the TV antenna lowered. Close the entrance door and retract the steps.
13. Raise the fifth wheel jacks so the entire hitch load is on the tow vehicle. The jacks should be about 2" off of the ground. Do not raise the jacks completely until you have tested the brake control. This will also test the hook-up.
14. Pull the unit forward and apply the hand control for the trailer brakes to be sure they are operating properly.
15. Completely raise the fifth wheel jacks.

Campsite Parking

If the campground does not have drive through sites, it is recommended to stop near the site and inspect it for slopes or uneven areas. Back into the site carefully. Watch for low-hanging limbs, posts, large rocks or other obstacles. Back in so the site is on the driver's left. This will enable the driver to watch the rear of the unit. Maneuver the vehicle into position before backing into the site. Back up slowly, using the side mirrors as a guide or with the assistance of another person outside, guiding the parking procedure.

Place the tow vehicle in park and turn off the ignition. Block all of the trailer wheels with wheel chocks. Side to side leveling should be done by using shims under the tires on the low side of the unit after it has been backed into the site. This must be done before disconnecting the trailer from the tow vehicle. Lower the stabilizing jacks, if installed. Connect the 120 volt shore power to the unit. Open the LP gas valves at the LP tanks. Connect the fresh water supply and sanitize the water systems (see Chapter 11), if necessary. Connect the waste drain hose to the sewer hook-up. Start the refrigerator, water heater, and furnace, if needed. Light the oven pilot light, if applicable. Remember that the refrigerator will not operate efficiently if the unit is not level.

CHAPTER 3

AIR CONDITIONING & HEATING

Table of Contents

Air Conditioning	3 - 1
Furnace	3 - 2
LP Bottles	3 - 3
LP Bottle Filling	3 - 3
LP Regulator	3 - 4
LP Detector	3 - 4

AIR CONDITIONER(S)

The roof mounted air conditioner(s) installed on your unit will operate only when the unit is supplied with 120 volt AC power from the power cord. The air conditioner circuit breaker must be in the ON position to work.

To assist the air conditioner in cooling the unit, park the vehicle in the shade and keep the drapes or blinds closed. Set the thermostat to the desired temperature and keeping the doors and windows closed.

Air conditioners can use a large portion of the available electric power. RV parks may experience low voltage on days with high heat or humidity. This is commonly referred to as a "brown out". A brown out may trip the air conditioner circuit breaker. The circuit breaker protects your air conditioner from damage and is necessary during low voltage conditions. The tripping breaker is not a fault in your electrical system.

The cool air from the air conditioner is ducted throughout the coach through ceiling ducts. Below is the thermostat that controls the air conditioner. It also controls the furnace. Simply select the desired temperature. The blower will cycle automatically, or you may choose low, medium or high fan settings.

Step One: Move power switch to ON.

Step Two: Press MODE button to select function. (COOL*, FURNACE, FAN ONLY, etc.)

* There is an approximate 2-minute time delay after selecting cooling function for refrigerant compressor to start.

Step Three: Press FAN button to select fan speed or automatic operation.

Step Four: Press UP or DN button to set your desired temperature for the zone.

Step Five: If your vehicle contains more than one zone, depress FAN and MODE simultaneously to select zone 2, and repeat procedures from step 2 above. Repeat entire procedure for each additional zone.

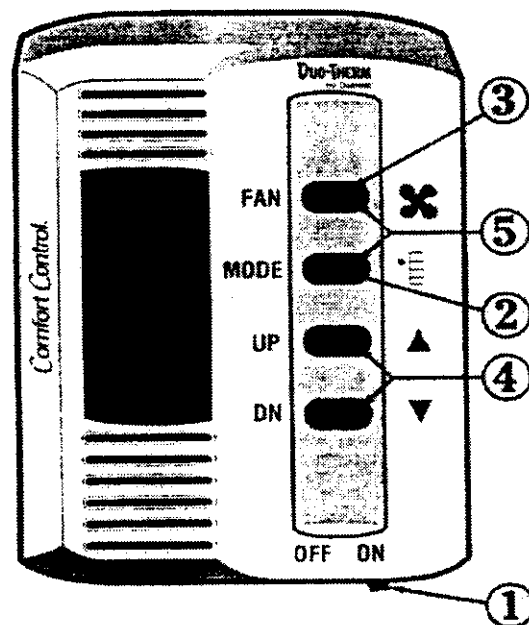

Shutdown: If you turn the Comfort Control off, or if there is a power interruption for any reason, the system will resume operation on the last settings when power returns.

FURNACE

WARNING

Never attempt to modify this furnace. Fire, explosion, asphyxiation, or carbon monoxide poisoning may occur. If the furnace malfunctions, consult a trained service technician.

The furnace(s) installed in your unit is a forced-air furnace fueled by LP gas. If your unit is equipped with two furnaces, the living area furnace is controlled by the air conditioner wall thermostat that controls the heating and cooling of the unit. The furnace installed in the bath/bedroom area is controlled by the thermostat in the bedroom.

The heat is supplied to the unit through ducts in the floor. The furnace will not operate properly if the air flow at the floor registers, or the air return to the furnace, is blocked by personal or storage items. Storage under the cabinets should be done carefully to prevent crushing or damaging the furnace ducting or blocking of the warm air return.

Smoke and fumes may be created as a result of the residual burn off of the manufacturing compounds that are sometimes present the first time the furnace is used. This is normal. To minimize the smoke and fumes, the initial lighting of the furnace should be done with the windows and doors open. Continue until the residue is completely burned off.

To operate, set the thermostat to the desired temperature setting and turn the thermostat to the on position. Allow 60 seconds for the furnace to begin operating. To shut down the furnace, turn the thermostat to the off position. After the furnace has been turned off, the fan will run for approximately 60 seconds to cool down.

For your safety, do not use gasoline or other flammable liquids in the vicinity of the furnace or any other appliance. Clean the complete furnace and air tube passageways periodically to remove dust, lint, etc. Check the gas system for leaks at least once a year. Check and clean the blower wheel annually.

On the exterior of the coach you will find a furnace cover. There are no owner serviceable parts on the furnace. This cover should be removed by authorized service technicians only.

WARNING

Use caution when washing the exterior of your vehicle. Water should not be sprayed directly into the furnace vent. If water is forced beyond the rain baffles into the furnace vent, rusting of the furnace could occur. This could also cause improper combustion.

The furnace should be thoroughly cleaned before the start of each heating season. Any debris in the system may restrict air flow for combustion, bind the combustion air impeller, or prevent the blower motor from running properly. Also, check the burner pilot orifices for debris. Lint accumulations may cause the blower to become unbalanced, vibrate, restrict the ability of the blower to move air. If lint is blown into the heat exchanger, it may cause odors or create a fire hazard. Contact an authorized service technician for annual cleaning. Consult the manufacturer's operating instructions in your owner's package for further information.

WARNING

Portable fuel burning appliances are not safe for heating inside the recreational vehicle. Asphyxiation or carbon monoxide poisoning can occur.

LP BOTTLES

This unit is equipped with two 30# LP bottles. Two 40# LP bottles are optional. These bottles are controlled with an automatic pressure regulator. The LP bottles contain liquid petroleum gas under high pressure. As the fuel is used, the liquid gas vaporizes and passes through the tank valve to a regulator that automatically reduces the pressure. The low-pressure gas is then distributed to the appliances throughout the pipe manifold system. Improperly adjusted regulators are the major cause of appliance lighting problems. Never attempt to reset the regulator. This is to be done by a qualified service technician. While in high altitudes or extreme cold weather a gas shortage may be experienced. Using one appliance at a time can help adjust to this problem.

It is recommended to have the LP system inspected by an authorized service technician at least once a year and after every extended trip. This system is tested by both the manufacturer and the dealer. Leaks can be caused by travel vibrations, therefore routine inspections are recommended.

The primary gas manifold is a black steel pipe running the length of the unit. All secondary lines leading to the gas appliances are made of copper tubing with flare fittings. If any of these lines rupture do not attempt to splice them. Always have a new line ran. Gas distribution work must be performed by an authorized service technician. When removing or servicing any gas appliance, close the main gas valve at the LP bottles. This will prevent dangerous gas leakage that could result in an explosion and possible serious injury. If a gas leak is suspected, have the system inspected and repaired by a qualified service technician as soon as possible.

WARNING

The main gas valve must be shut when the vehicle is not in use. Shut the valve off when refueling to avoid potential danger from pilots lights igniting fuel fumes. Gas valves on appliances with direct spark ignition (DSI) should also be in the off position. Do not store LP, gasoline, diesel, or other flammable liquids inside the vehicle. Fire or an explosion could be the result of ignoring this warning.

LP Bottle Filling

Do not fill the bottles to more than 80 percent of capacity. Fire or explosion may be the result of uncontrolled gas flow from an overfilled tank.

LP Regulator

The regulator is the heart of the LP system. The regulator reduces the pressure of the gas so it is safe to use with various appliances. Regulators are equipped with a vent. In the event excess pressure builds up in the body of the regulator, a relief mechanism vents it to the atmosphere. It will vent until the pressure returns to the normal range. The vent must be kept clean and clear of obstructions or corrosion. A clogged vent could cause the failure of components. Contact a qualified LP technician if corrosion or obstruction is noticed.

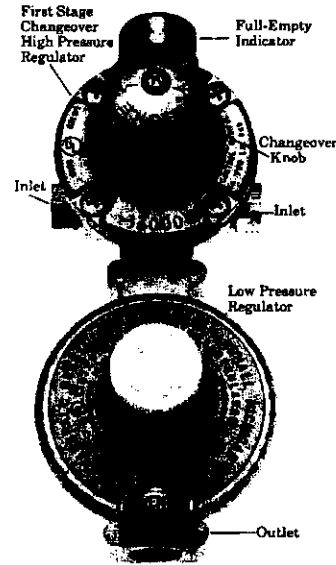

The presence of moisture in LP fuel causes the regulators to freeze. The moisture will pass through the cylinder valve and into the regulator where freezing occurs. To help prevent the regulator from freezing, always keep the tank control valve closed when not in use, even when the tank is empty, to prevent moisture from collecting on the inside.

If moisture becomes a problem, consult an authorized LP service center for assistance.

LP Gas Detector

WARNING

Never check gas lines for leaks with an open flame. Do not check for leaks using ammoniated or chlorinated household type detergents. These detergents can cause cracks to form on the metal tubing and brass fittings. Take the unit to a qualified LP gas service technician to find and repair the leak. Keep the tank valve closed and all of the appliances turned off when the unit is stored. If any of the LP gas valves do not close leak-tight by hand, consult a service technician.

Notes

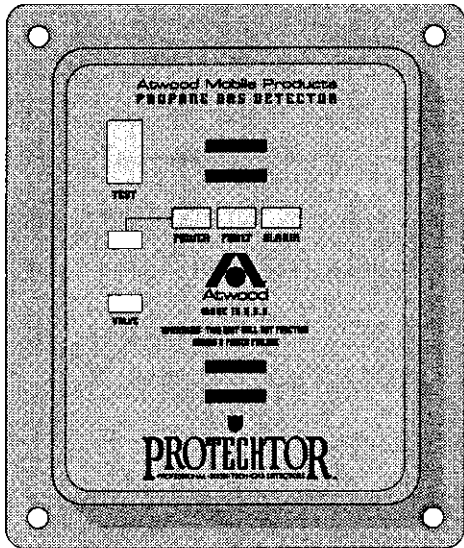

Liquid Propane (LP) Gas is heavier than air and will settle to the lowest point of the room, which is generally the floor of your coach. Because of this, the LP detector installed in your coach is located near the floor. The detector is also sensitive to other fumes, such as hair spray, of which most contain butane as the propellant. Butane, like propane, is heavier than air and will settle to the floor level where it may be detected.

Notes

CHAPTER 4

APPLIANCES & ACCESSORIES

Table of Contents

Refrigerator	4 - 1
Microwave	4 - 2
Range Hood	4 - 2
Range	4 - 2
Television Antenna	4 - 3
Television	4 - 4
Video Control Center	4 - 4
VCR Prep	4 - 5
Cable Jack	4 - 5
Telephone Jack	4 - 5
Stereo	4 - 5
Water Heater	4 - 5
Water Heater Storage	4 - 6
Water Heater Relief Valve	4 - 6
Washer/Dryer	4 - 7

MAJOR APPLIANCES

Refrigerator

Before starting the refrigerator, verify that the main LP gas valve is in the on position. The refrigerator is equipped with eye-level automatic-manual electronic controls with automatic LP ignition system. It can be set to select either 120 volt or LP gas operation, automatically, if desired.

WARNING

Most LP gas appliances used in recreational vehicles are vented to the outside of the vehicle. When parked close to a gasoline pump it is possible that the gasoline fumes could enter this type of appliance and ignite the burner flame causing a fire or explosion. Use caution when refueling.

A 12 volt power supply must be available for the electronic control panel to function. The shore line must be plugged in, or the optional generator running, to operate in the 120 volt mode. The main LP gas valve must be open for operation in the LP mode. To start the refrigerator, press the main power ON/Off button to the ON position.

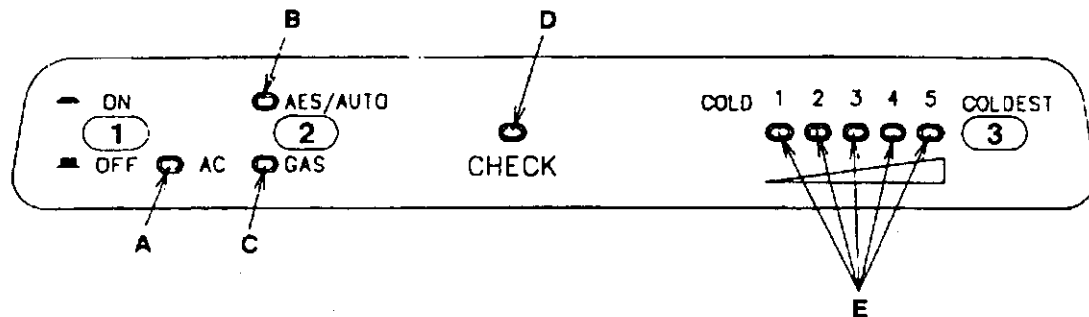

LEGEND 2-WAY AES Model

1. Main Power Button ON/OFF
2. AES/AUTO/GAS Mode Selector Button
3. Temperature Selector Button

- A. AC Mode Indicator Lamp
- B. AES/AUTO Mode Indicator Lamp
- C. GAS Mode Indicator Lamp
- D. CHECK Indicator Lamp
- E. Temperature Indicator Lamps

To use the 2-way Auto Mode, push the AUTO/GAS mode selector into the ON position. If 120 volt is available, the AC mode indicator light will be illuminated designating AC operation. If 120 volt is not available, the gas mode indicator light will be illuminated. The control system will automatically switch to gas operation. To operate on gas only, push the AUTO/GAS mode selector until the gas indicator light has lit. After 45 seconds, the burner should be ignited and operating normally. The initial start up may take longer than 45 seconds in order to allow the air to be purged from the gas line. If the gas does not ignite within 45 seconds, the check indicator light will illuminate and the gas mode light will go off. If the check indicator light illuminates and the gas mode indicator light is off, then the controls have failed to ignite the burner in the gas mode. When the check indicator light is on, press the main power ON/OFF button to the off position to reset. Do not continue to reset the gas operation if the check indicator light continues to illuminate after several tries.

The thermostat on the refrigerator controls the gas and electric operation. This eliminates the necessity of resetting the temperature each time a different energy source is used. Press the temperature selector button until the light at the desired setting is illuminated. After the initial start up, the thermostat should be moved from the coldest setting to the desired setting, which is usually mid range.

An optional feature on the Dometic refrigerator is the addition of an automatic ice maker in the freezer compartment. For detailed operating instructions, please consult the manufacturer owner's manual in the owner's package.

Microwave

Your unit is equipped with a 22" microwave oven. A 30" microwave oven or a 30" convection microwave with a three-burner cooktop is optional. The microwave's control panel is the touch pad type. Simply enter the temperature, mode, and cooking time desired. The microwave is plugged into the electrical outlet through a surge protector. This will help protect the microwave in case of an electrical surge. For instructions on how to operate any of the special features on the microwave oven, please refer to the microwave owner's manual in your owner's package.

Range Hood

The standard range hood is a separate appliance installed above the range, below the microwave. This range hood has both a fan and a light for your convenience. It is operated by turning the switch for the light either on or off, and the switch for the fan to low, high, or off. Consult the range hood owner's manual for further instruction on the hood operation.

Range

The standard range installed in your unit contains both a range top and an oven. There is no pilot light for the stove top. The burners are controlled by a spark ignition. There are different models used in the Newmar product line with different types of controls. To light the burners on some models, turn the control knob to turn the gas on. Wait a couple of seconds, then push the red spark button until a flame appears. On other models, after the gas control has been turned on, turn the spark control knob until a flame appears. All burner controls operate counter clockwise and have to be pushed inward in order to turn. The oven control must also be pushed inward before turning. To light the oven, push in the oven control knob and rotate counter clockwise to the PILOT ON position. Light the oven pilot light which is located at the back, left-hand side of the oven burner. The oven pilot may be slow in lighting due to initial air in the gas line. The oven pilot has been factory adjusted. No further adjustments are necessary. To extinguish the oven pilot, push in the oven control knob and turn clockwise to the Off position. For further instructions, please refer to the oven manufacturer owner's manual in your owner's package.

The following warning label has been placed in the cooking area to remind the user to provide an adequate supply of fresh air for combustion:

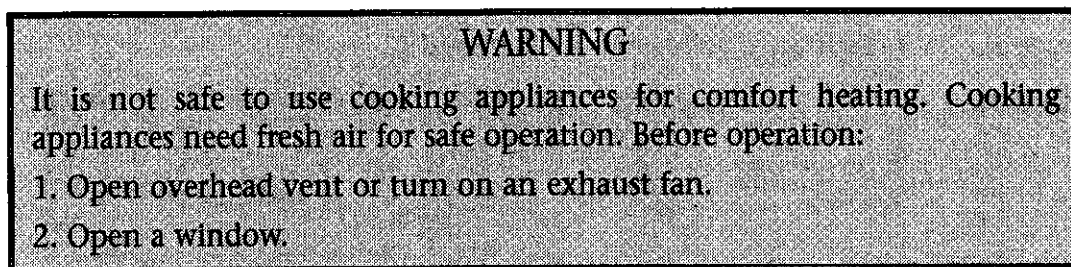

Unlike homes, the amount of oxygen supply is limited due to the size of the recreational vehicle. Proper ventilation when using the cooking appliance(s) will avoid dangers of asphyxiation. It is especially important that cooking appliances not be used for comfort heating as the danger of asphyxiation is greater when the appliance is used for long periods of time.

The following label has been placed in the vehicle near the range area:

If You Smell Gas:

1. Extinguish any open flames, pilot lights, and all smoking materials.
2. Do not touch electrical switches.
3. Shut off the gas supply at the tank valve(s) or gas supply connection.
4. Open doors and other ventilating openings.
5. Leave the area until the odor clears.
6. Have the gas system checked and leakage source corrected before using again.

TELEVISION OPERATION

AntennaTek Television Antenna

The TV antenna in your unit is designed for reception of all color and black-and-white channels. If the reception is poor, you should verify that the power switch is in the "ON" position and that all of the connectors are tight. If poor reception still occurs, consult your authorized dealer.

To raise the antenna into the operating position, rotate the elevation handle clockwise. A clicking sound will occur when the antenna is completely extended. Switch on the main power supply. Note the red LED indicator illuminated. This indicated amplified reception. Switch on the television and tune in a suitable station. Pull the rotation handle down to disengage the gear from the ceiling plate and rotate the antenna until the picture and sound are the clearest.

RAISING ANTENNA TO OPERATING POSITION

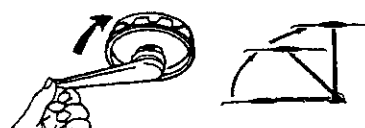

ROTATING ANTENNA FOR BEST PICTURE



LOWERING ANTENNA TO TRAVEL POSITION

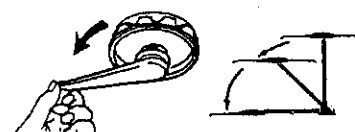

To lower the antenna, pull the rotation handle down to disengage the gear from the ceiling plate and rotate the antenna until the pointer on the ceiling plate is aligned with the pointer on the rotation handle. Rotate the elevation handle counter-clockwise until you hear the antenna touch the roof. Resistance will be felt in the handle.

CAUTION

Lowering the antenna with the pointers misaligned will damage the gears or the elevating handle.

You may want to switch your main power supply off. Amplified reception is possible if the antenna is in the full down position.

Television

With the installation of the antenna, the unit is ready for the addition of a television. The television would be located in the entertainment center of the living room. Most televisions are powered by 120-volt electricity. Your unit must be plugged into shore power in order for the television to work.

Video Control Center (Optional)

If the optional Audio Video Control Center is installed in your vehicle, it will direct the signal being received by up to two televisions and one VCR. Simply push a button to select what is viewed and where. To control what is being viewed on the front television use the selections for "TV 1". To control what is being viewed on the bedroom (and outside television, if installed) use the selections for "TV 2". Each television is capable of viewing different programming at the same time. For example, by selecting "ANT" for "TV 1" you are able to watch your favorite network broadcast on the front television, while a movie from the VCR is being watched in the bedroom or outside, after selecting the "VCR" button for "TV 2". This control center is capable of receiving three sources of input. They are "FROM ANTENNA", "FROM VCR", and "FROM AUX". The "FROM AUX" selection is used for cable input. It will also accommodate video game systems.

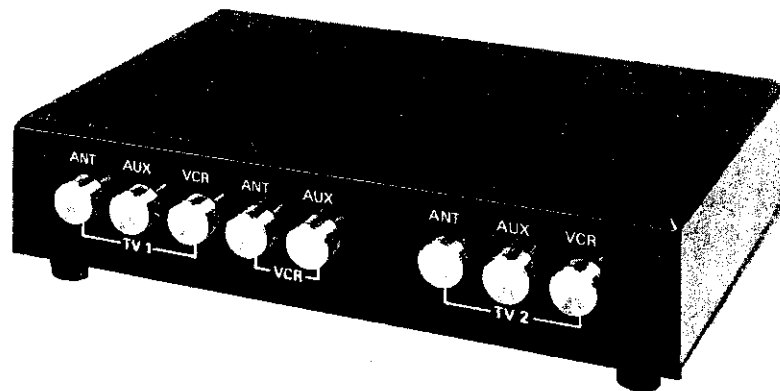

VCR Prep (Optional)

This option prepares the unit for the installation of a video cassette recorder (VCR). The video switch described above will assist you in directing the VCR signal to the television of your choice.

Cable & Telephone Jack

Two cable television jacks are installed as standard equipment on your unit. If optioned, the exterior television jack would have been installed on the door side of the unit. An additional feature in this unit is the telephone hook up. This feature includes the connector for the incoming telephone line and one telephone outlet inside the unit. An exterior telephone jack may be optioned.

Stereo

The standard stereo that is installed in your unit is an AM/FM stereo with a cassette and compact disc player. There are speakers located throughout the unit for listening pleasure. The operation of the stereo is similar to that of many car stereos. It operates on 12 volt electricity from the coach batteries. For further information on the operation of this stereo, consult the stereo owner's manual in the owner's package.

WATER HEATER

WARNING

Do not light the water heater until it is filled with water. There is a switch on the exterior of the water heater labeled "Electric". This switch must be in the "ON" position for the water heater to work in the electric mode.

Before lighting the water heater fill the fresh water system. Purge any air from the water heater by opening all hot water faucets until water flows steadily from each one. The water heater installed in this unit is a 10 gallon gas/electric model with direct spark ignition.

It is important to read all of the safety information provided in the water heater manufacturer operation manual in the owner's packet. At the water heater, place the re-ignitor control in the "OFF" position. Turn the gas cock (A) clockwise to the "OFF" position and the temperature indicator to the lowest setting.

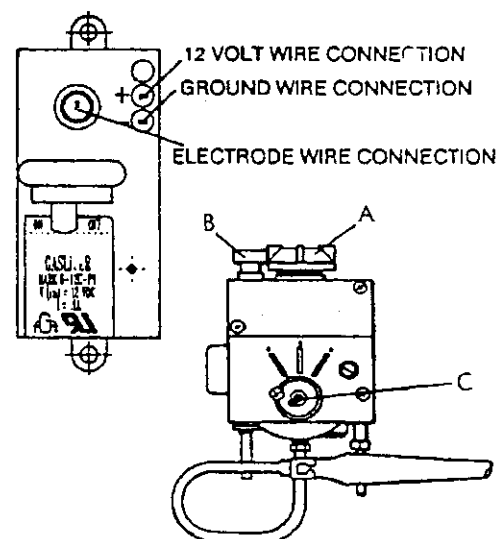

Turn off all electrical power to the water heater. Wait five (5) minutes for gas to clear the area. If you smell gas, STOP. Follow the instructions in the safety information sections of the Operation Manual. If no gas odor is present, continue to the next step. Turn on the gas supply. Turn on the electrical power to the water heater. Turn the gas cock (A) counter clockwise to the "PILOT" position. Press the reset button (B) and switch the electric re-ignitor module to the "ON" position. The re-ignitor will start to spark between the electrode tip and the pilot hood. When the pilot lights, the spark will stop. Continue depressing the reset button (B) for approximately one minute or until the pilot light remains lit. On the initial start-up, it may take several minutes before the pilot light ignites in order to purge the air from the gas lines. Turn the gas cock (A) counter clockwise to the "ON" position. Set the temperature dial (C) to the desired setting. When the re-ignitor is in the on position, it will operate automatically if the pilot flame is accidentally extinguished. The re-ignitor is equipped with an alarm that will sound when the pilot light is extinguished or if the LP supply is turned off. The alarm will serve as a reminder to turn the re-ignitor off.

WARNING

Do not store any combustible materials or liquids near or adjacent to the water heater.

Water Heater Storage

When storing your unit for the winter months, the water heater must be drained to prevent damage from freezing. The first step is to turn off all electrical power and LP gas going to the water heater. The water pump must also be turned off. Open both the hot and cold water faucets to drain the lines. Open the drain on the water heater. Drain the entire water system. When preparing the unit for use after it has been stored, make certain the water system, including the water heater has been filled before re-lighting the water heater. Failure to fill the water heater before lighting may damage the water heater and void the warranty.

Pressure Relief Valve

The temperature and pressure relief valve is designed to open if the temperature of the water within the heater reaches 210° F, or if the water pressure in the heater reaches 150 pounds. Recreational vehicle water systems are closed systems and during the water heating cycle the pressure build-up in the water system may reach 150 pounds. When this pressure is reached, the pressure relief valve will open and water will drip from the valve. This dripping will continue until the pressure is reduced to below 150 pounds, and the valve closes. This condition is normal and does not indicate a defective relief valve.

WARNING

Do not plug the relief valve under any circumstances.

CHAPTER 5

CABINETS & FURNITURE

Table of Contents

Cabinets	5 - 1
Furniture	5 - 2
Living Room Area	5 - 2
Bedroom Area	5 - 3

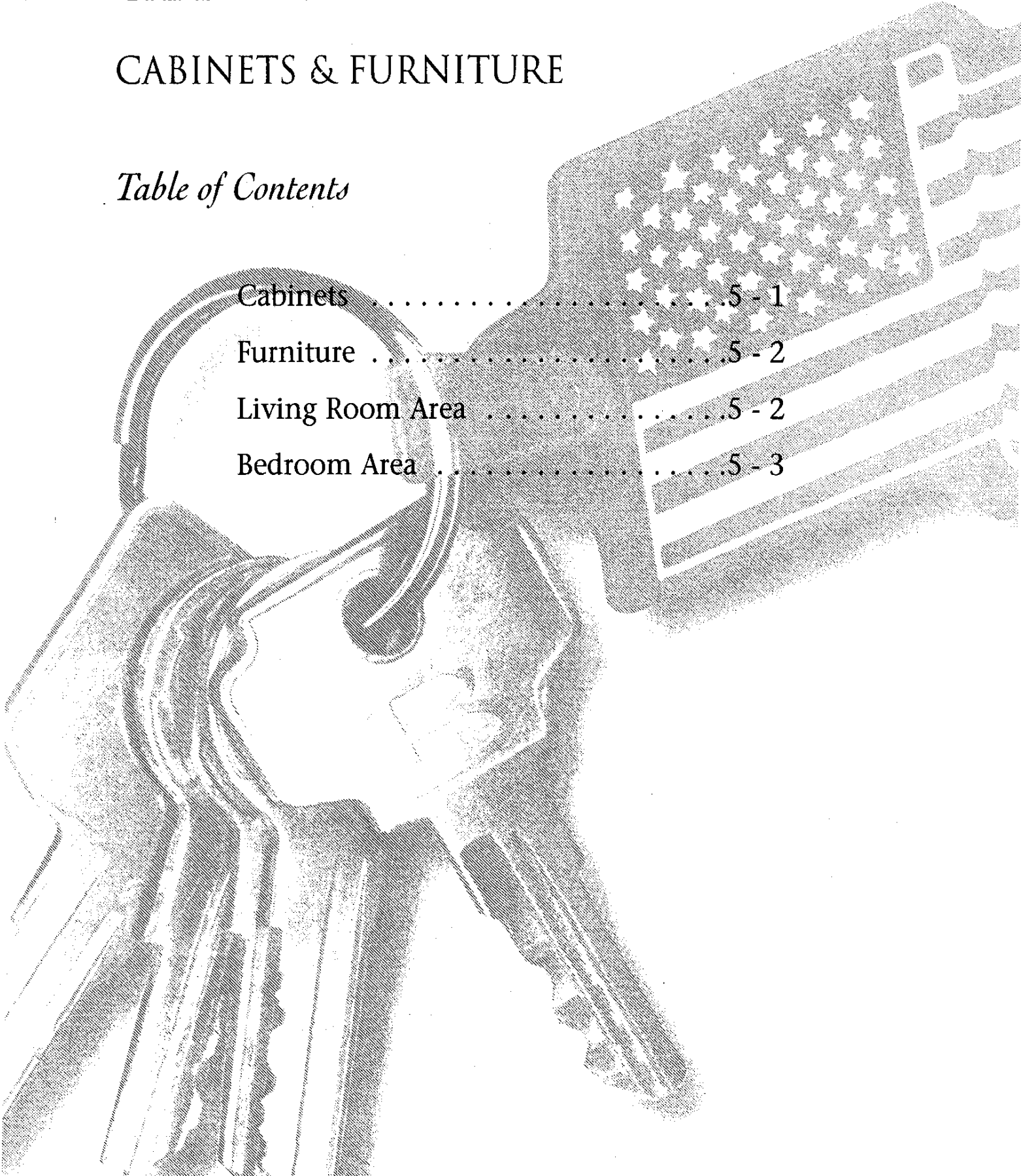

CABINETS

The cabinets in this unit are constructed on site at the Newmar production facility. Hardwood frame doors with raised panels are standard throughout the unit. Brass door and drawer pulls give the interior an added touch of class. The glass door panels in the living room entertainment center allow for viewing the lighted mirrored interior of the cabinets.

Some models have the optional countertop extension in the kitchen. This provides additional counter space while cooking, and folds out of the way while entertaining. The silverware drawer contains a molded silverware divider tray for added storage.

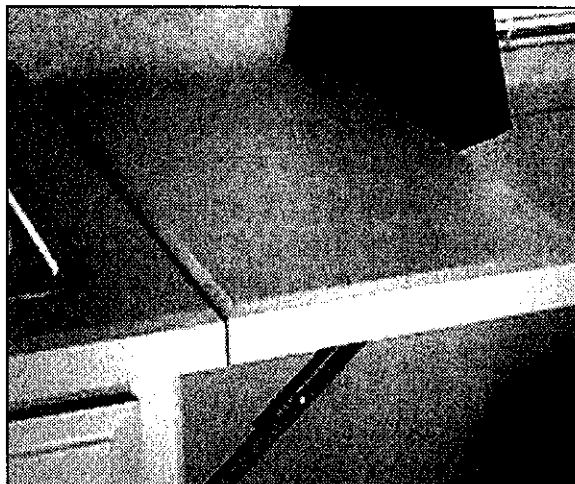

Storage is an important factor to all RV owners. Keeping this in mind, the cabinetry is structured to provide as much storage as possible. Some models have pantry style cabinets in the kitchen for added storage. On other models, you may option a pull out pantry for storage ease. In the bedroom on all models, the bed platform lifts for convenient storage. This platform is held open by gas struts to allow hands-free access.

The countertop in the kitchen and bath is made of a decor matching Corian®. The "drawer" directly in front of the kitchen and lavatory sink does not pull out, but rather flips down. This provides a storage tray for dish cloths, scouring pads, wash cloths, etc.



All of the cabinetry can be easily cleaned with any commercial furniture cleaner or polish. As with any wood product, do not saturate these cabinets with water or any other liquid. Be sure to wipe up spills as they occur to avoid staining.

FURNITURE

Living Room Area

A standard feature in the kitchen area is the free-standing dinette. This includes a hardwood table and four chairs on floor plans. The chair seats and backs are designed with a coordinating upholstery fabric to match your decor.

One popular option in this unit is the built-in dinette booth. The built-in dinette would be installed in place of the free-standing table and chairs. The dinette provides added storage under the seat area of the booth, along with an extra sleeping area. The sleeping area is made by lowering the table top and re-arranging the cushions.

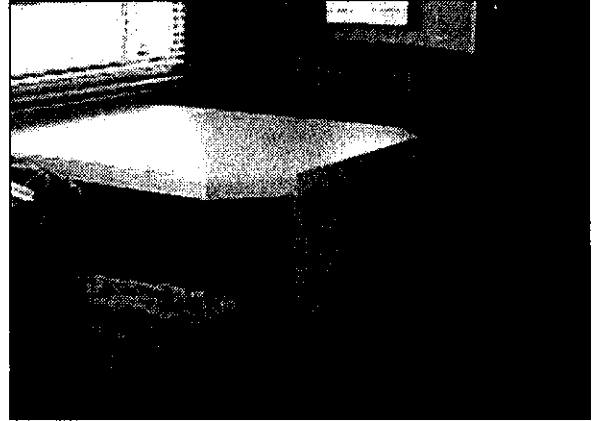

Another option is the hidden leaf dinette table. This option is in place of the standard dinette table.

In the living room, depending on the floorplan of your fifth wheel, the standard sofa is a Hide-A-Bed or Magic Bed sofa. The sofas are upholstered in decor matching fabric. If you have any questions regarding the warranty on this sofa, contact Flexsteel, the sofa manufacturer.

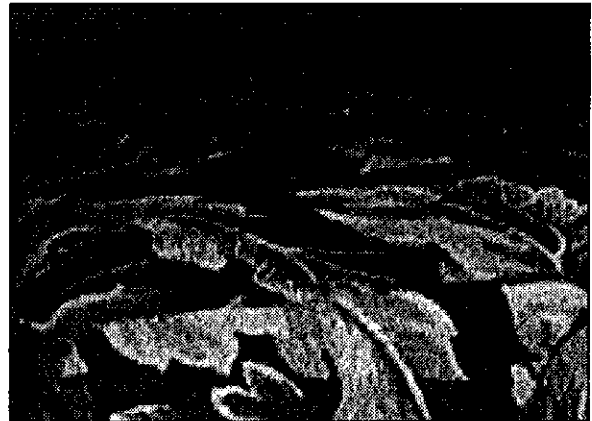

A popular sofa option on models with a slide out is the Flexsteel 74" Hide-a-Bed sofa. This sofa is a traditional hide-a-bed. Before converting the sofa, extend the slide out (See Chapter 8 for slide out instructions.) to make room for the bed. Once the room is extended, remove all of the seat cushions. Next, take hold of the handle on the bed mechanism and pull to extend. Expand the bed to the fully open position by unfolding the foot portion of the bed.



CHAPTER 6

STRUCTURE FEATURES

Table of Contents

Structure Features	6 - 1
------------------------------	-------

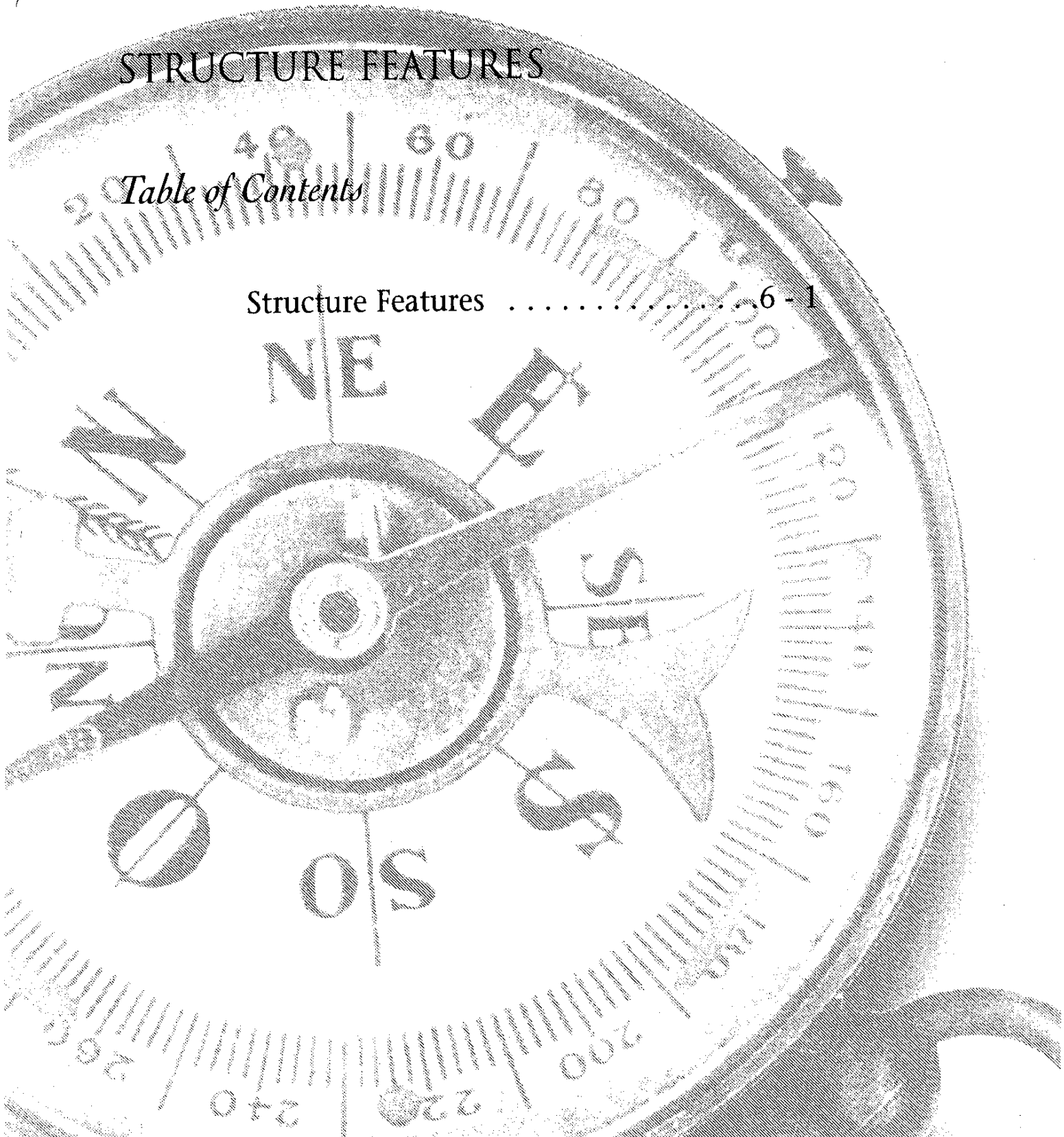

STRUCTURE FEATURES

All models have 12" I-Beam steel frame construction with maximum storage capabilities. All frames are manufactured at the Newmar production facility. Doing this ensures the control of quality that Newmar insists upon.

Skid bars are installed on all fifth wheels as a standard feature. These will help prevent accidental damage when encountering dips or steep inclines.

Shock absorbers are another standard feature on the fifth wheel units. Installation of these will assist in cushioning the trailer when pulled on rough, uneven roads. They also help stabilize the unit.

All of the fifth wheel models have the easy lube equalizers. With multiple axle installation, the movement of the equalizer assembly serves to transfer instantaneous loads from one axle to another in an effort to "equalize" the load. The equalizers installed are equipped with grease zerks for ease of maintenance.

Notes

CHAPTER 7

ELECTRICAL FEATURES

Table of Contents

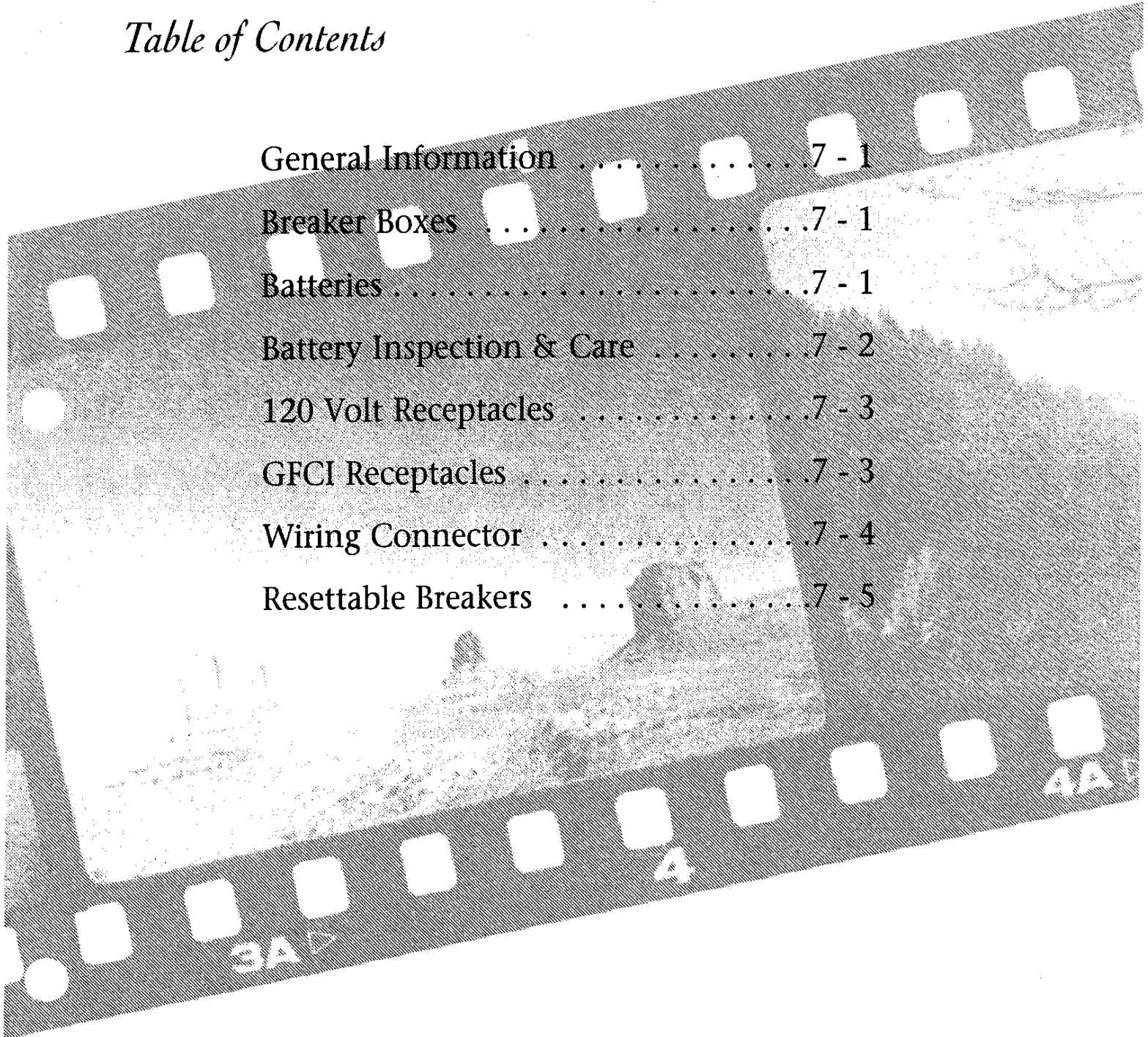

General Information	7 - 1
Breaker Boxes	7 - 1
Batteries	7 - 1
Battery Inspection & Care	7 - 2
120 Volt Receptacles	7 - 3
GFCI Receptacles	7 - 3
Wiring Connector	7 - 4
Resettable Breakers	7 - 5

ELECTRICAL SYSTEMS

General Information

There are two electrical systems in your coach. They are the 12 volt DC system and the 120 volt AC system. Most standard appliances require the 120 volt system while the majority of the lighting used in recreation vehicles is powered by 12 volt. The power for the 12 volt system is supplied by the coach batteries. The power for the 120 volt systems is supplied by the power cord when the unit is connected to an outside power source or by the generator, if so equipped. When connected to shore power, the standard 55 amp power converter will automatically charge the batteries as well as convert 120 volts into 12 volts.

To connect the unit to 120 volt shore power, first make sure all of the breakers are in the off position. This is done to avoid a power surge. Unwind the power cord from the electrical compartment. The standard electrical service in this unit is 30 amps. A 50 amp service with flexible power cord can be optioned in place of the standard. Check to make sure the pins in the outlet are oriented correctly, that they match the power cable, and that they are in good condition. If there is a circuit breaker switch at the plug, it should be turned OFF before making the connection. Insert the plug completely into the outlet and turn the circuit breaker on. Close, and lock the electrical compartment door to keep the contents clean, dry, and secure. Close the cover on the power box, if equipped, to avoid an unintended disconnection, and to keep contents clean. Switch the main breaker to the 'ON' position. The 120 volt system will energize all 120 volt circuits and outlets when the main breaker is turned on.

Breaker Boxes

The 120 volt and 12 volt breaker boxes are generally installed in a bedroom cabinet. Circuit breakers and fuses are installed to protect the electrical system from overloading. Do not attempt to change the circuitry or add appliances yourself. Please consult an authorized Newmar Service Center.

Batteries

The battery on your unit is installed by Newmar Corporation. This battery is warranted by the battery manufacturer. It is used to operate the 12 volt items in the unit. The battery also operates the water heater's electronic ignition, landing jacks, etc. In-line breakers protecting these circuits are found near the battery. If the tow vehicle is equipped with a charge line, the tow vehicle's electrical system will charge the coach battery while in transit. The power converter automatically charges the coach batteries when the unit is connected to a 120 volt outside power source.

Battery Inspection & Care

WARNING

Remove rings, metal watch bands and other metal jewelry before working around batteries. Use caution when using metal tools. If a tool contacts a battery terminal or metal connected to it, a short circuit could occur which could cause personal injury, explosion or fire.

CAUTION

Disconnect the 120 volt electrical power cord and the negative terminal from the coach batteries before working on the electrical system.

Remember, when a battery is not used for an extended period of time, it may lose its charge. Periodic charging of the battery during storage of the unit will increase the life of the battery. Check the external condition of the battery periodically. Look for cracks in the cover and case. Check the vent plugs and replace them if they are cracked or broken. Keep the battery clean. Accumulations of acid film and dirt may permit current flow between the terminals, which could drain the battery.

To clean, wash the battery with a diluted solution of baking soda and water to neutralize any acid present. Rinse thoroughly with clean water. Foaming around the terminals or on top of the battery is a sign that acid is being neutralized. Avoid getting the baking soda solution in the battery. Secure all vent caps. Dry the battery cables and terminals. Do not use grease on the bare metal inside the cable terminals to prevent corrosion. Grease can act as an insulator. Electricity will not flow through it. A plastic ignition spray will protect the terminals after they have been cleaned.

WARNING

Do not allow the battery fluid to contact your skin, eyes, fabric, or painted surfaces. The fluid could cause serious personal injury or property damage. Wear eye protection when working with any battery.

When storing the unit for a short period of time, the battery should be disconnected from the coach to prevent draining. As an option, your unit may be equipped with a battery disconnect switch. Simply push the switch to the store position when storing your unit. To use the unit again, simply push the switch to the use position. If the unit is not equipped with a disconnect switch, disconnect the cables directly from the battery. When not using your unit for an extended period of time, the battery should be removed and stored in a warm place. Mark the cables, positive and negative, for easy identification. Batteries are not to be stored on concrete floors. The battery may require periodic charging during storage. If the unit is to be stored for a long period of time, it is recommended that all the batteries inside the unit be removed from clocks, radios, smoke alarms, etc. This will prevent unnecessary drain and corrosion of the batteries. The coach battery is a deep cycle RV/marine battery. This type of battery consumes water and must be filled periodically. Consult the owner's manual supplied by the battery manufacturer. This can be found in the owner information package received with this unit.

120 Volt Receptacles

For your convenience, there are 120 volt receptacles located throughout the interior of the unit. There are also exterior outlets located on the curbside of the coach. These receptacles require the three-pin plugs that provide proper grounding to protect you from electrical shock. Do not use an adapter, cheater, or extension cord that breaks the continuity of the ground circuit to the ground pin. Never remove the ground pin from a plug in order to connect it to a two pronged ungrounded outlet. Never operate the camping vehicle with an electrical short. An electrical short may cause the exterior of the unit to shock you when touched. If you feel even the slightest shock, disconnect the unit from the 120 volt power source and locate the fault. It is usually a break in the grounding circuit. The grounding circuit must be continuous from the frame to the distribution panel, to the power cord, to the earth ground.

Ground Fault Circuit Interrupt Receptacle

The 120 volt electrical outlets in the kitchen and bath area are ground fault circuit interrupt (GFCI) receptacles. The GFCI outlets provide an overload and short circuit protection. The electrical outlets located in the slide out are wired through the kitchen GFCI. The exterior electrical outlets are wired through the bathroom GFCI. If an item plugged into a slide out or outside receptacle is not working, check for a tripped GFCI in the kitchen or bathroom. In addition, these outlets protect the user from ground faults between a hot wire and ground. The GFCI will not reduce the shock hazard if the short is between a neutral and hot wire, or two hot load wires.

The GFCI should be tested at least once a month. The 120 volt electrical system must be on in order to test the GFCI. The reset button needs to be pushed in all of the way before starting the test. Push the test button. This will cause the reset button to pop out which means that the protected circuits have been disconnected. Push the reset button back in until a click is heard. This will reactivate the protected circuit. If the GFCI is working properly the reset button will remain in the 'IN' position.

Electrical Diagrams

Typical electrical diagrams can be found in chapter 15.

Notes

Wiring Connector

The wiring connector installed on all Newmar fifth wheels is the standard seven pin connector. The 12 volt battery in the tow vehicle supplies power to the trailer's electric brakes, tail lights, brake lights, turn lights, etc. through this connector. The color scheme for the wiring pigtail is as follows:

Left Turn Signal	Red	Clearance	Green	Charge	Black
Right Turn Signal	Brown	Ground	White	Brakes	Blue
		Back Up Lights	Yellow		

Below is the diagram of both the trailer and tow vehicle side of the pigtail. As stated above, this is a standard seven pin pigtail.

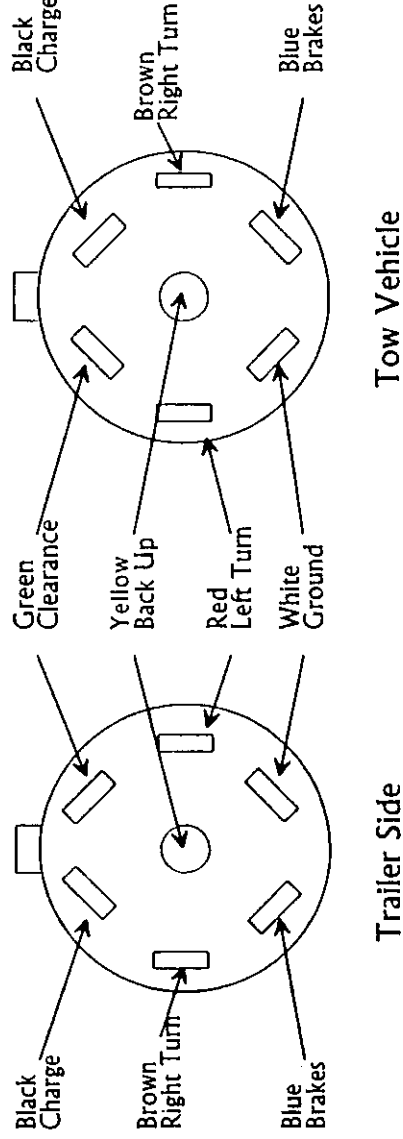

Notes

RESETTABLE BREAKERS

The resettable breakers are located within 18 inches of the source of power. This is the converter and the battery. (Figure 1)

When either of the breakers are shut down they must be manually reset.

To find the breakers, follow the line from the battery or converter approximately 18 inches.

This may lead to a junction box or to a cabinet inside the unit or similar location.

Manually reset the breaker as shown at right in Figure 2.

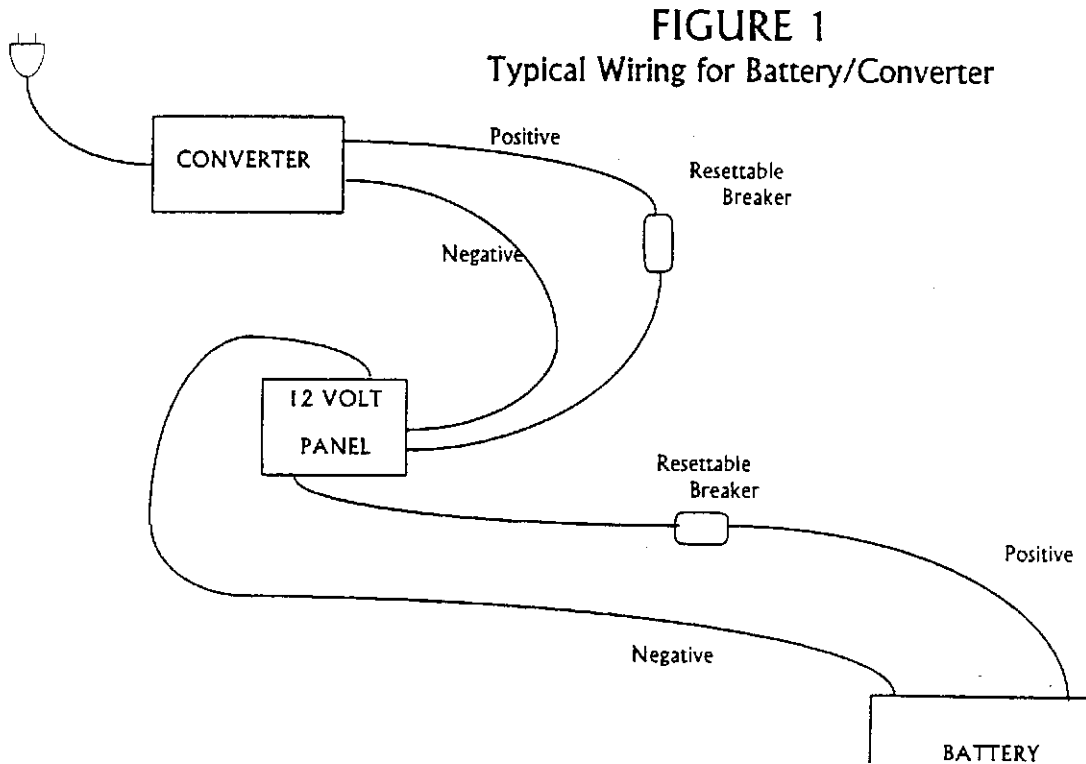
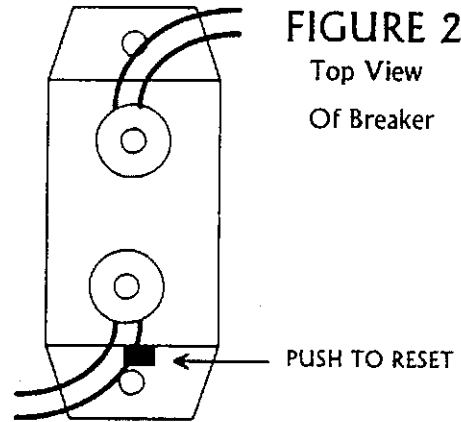

CHAPTER 8

SLIDE OUT FEATURES

Table of Contents

General Instructions	8 - 1
Extending	8 - 2
Retracting	8 - 2
Manual Operation	8 - 2
Operating Precautions	8 - 3

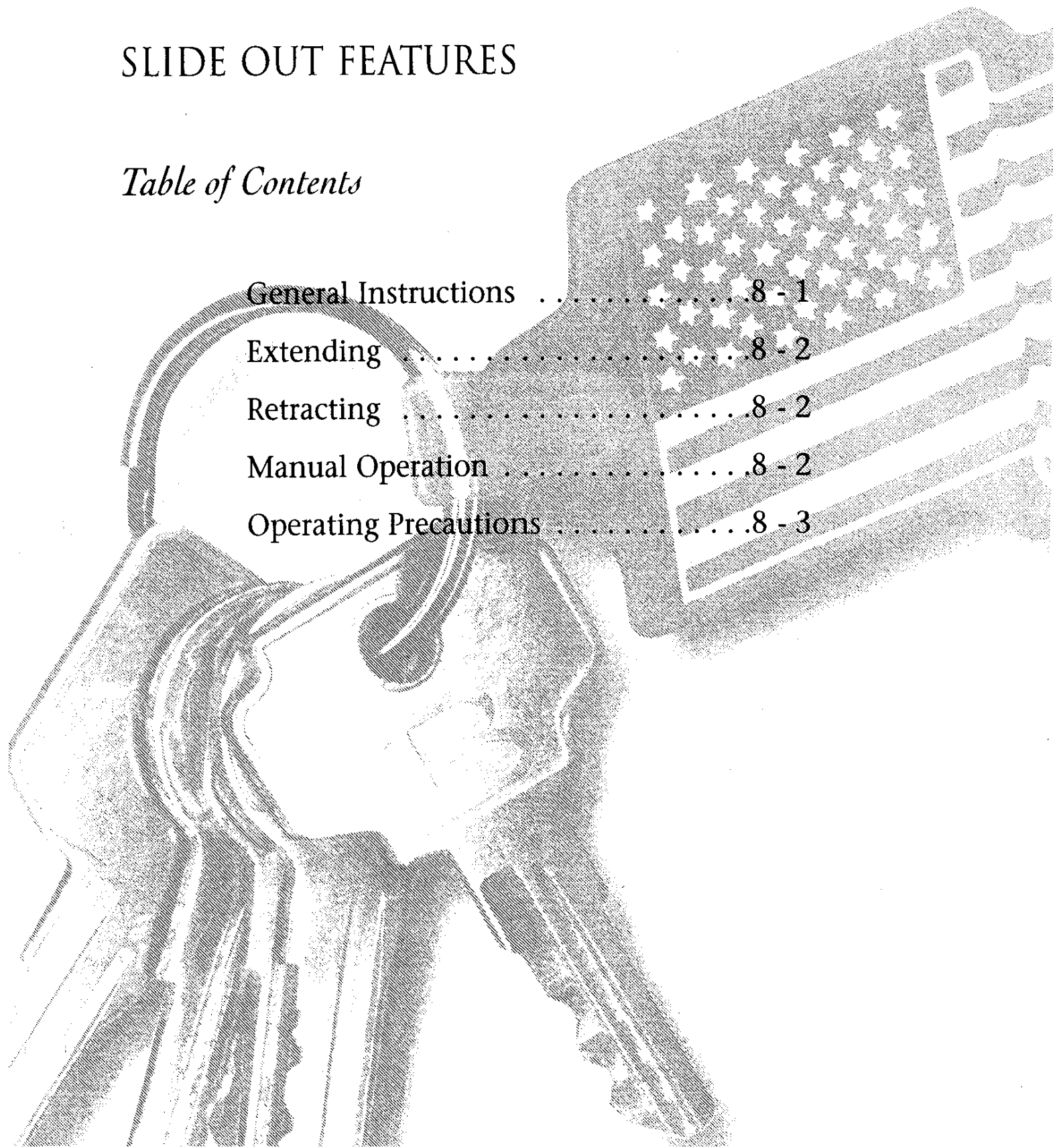

WARNING

READ THE FOLLOWING SLIDE OUT ROOM INSTRUCTIONS BEFORE ACTIVATING THE SWITCH.

IMPORTANT

The slide out room should be inspected for alignment every six (6) months. If alignment is necessary, have the room adjusted.

GENERAL INSTRUCTIONS

1. The slide out room can be stopped at any time by activating the slide out switch. The room will reverse directions each time the switch is activated.
2. If the slide out room stops before reaching the full 'OUT' or 'IN' position, the slide out controller may need adjustment.
3. To adjust the slide out controller, turn the adjustment screw clockwise to increase the power and counter-clockwise to decrease the power.

CAUTION

Move the adjustment screw in small increments. Try moving the slide out room again. Use caution. There is a potential for component or structural damage if the screw is adjusted too high.

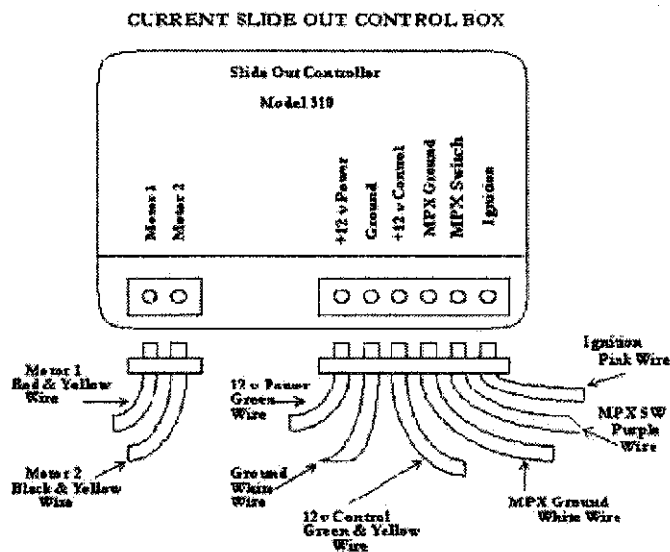
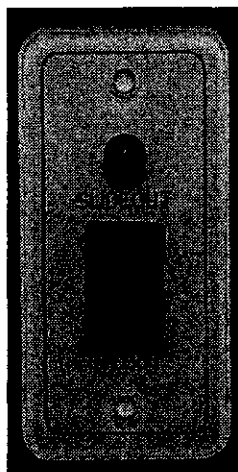

IMPORTANT

This screw does not adjust the slide out room speed. It sets the amount of power required to move the room against the mechanical stops.

Extending the Slide Out Room

1. The windows on the end of the slide out room must be closed before moving the room in either direction.
2. Before extending or retracting the room, look for and remove any obstructions.
3. Move the driver's chair (if applicable) forward before moving the slide out room in either direction.
4. Disengage the lock arms by pulling down on the center of the arm using the lock arm release tool, as required.
5. Activate the slide out switch. Once fully extended, the room will automatically stop. The indicator light will be lit while the room is traveling.

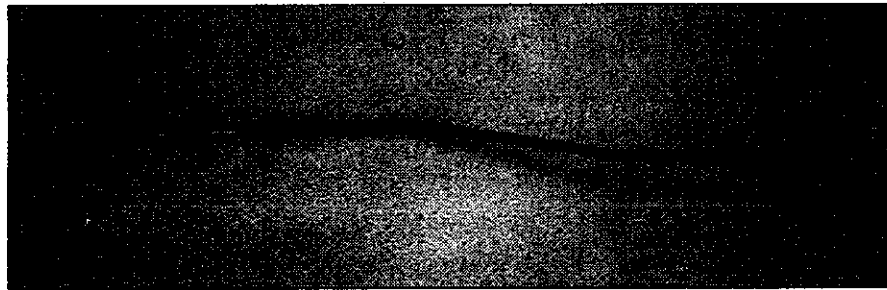

Retracting the Slide Out Room

1. Activate the slide out switch. When fully retracted, the room will automatically stop. The indicator light will be lit while the room is traveling.
2. Before moving the coach, engage the lock arms by pushing the arm up into the locked position using the lock arm tool, as required.

Manual Extension & Retraction

SHAFT END-MOUNTED MOTORS

If the motor is mounted on the ends of the slide out shaft, use the following directions:

1. Access must be gained to the TRANS-TORQUE bushing coupling at the end of the slide out gear motor.
2. Using a $\frac{1}{2}$ " drive - $1\frac{1}{2}$ " open end wrench and a $\frac{1}{2}$ " drive ratchet wrench, loosen the $1\frac{1}{2}$ " nut. This will require approximately $1\frac{1}{2}$ turns. The nut is a standard right hand thread. After the initial release, the nut will turn for a partial turn, then will release again as you turn the wrench. This second release is required to loosen the TRANS-TORQUE bushing from the shaft.

SHAFT CENTER-MOUNTED MOTORS

If the unit is equipped with the K-900 slide out motor which is mounted near the center of the slide out room, use the following directions:

1. Access must be gained to the slide out motor located in the center of the slide out room.
2. The manual extension or retraction requires only a $\frac{5}{8}$ " socket and ratchet wrench. By placing the socket on the $\frac{5}{8}$ " hex nut located on the gear box of the K-900 motor, the slide out can be moved in either direction by turning the hex nut.
3. If the slide out does not move by using the hex nut, the room can also be extended or retracted by using the procedure described for the SHAFT END-MOUNTED MOTORS. If the room is moved using this method, the correct torque on the $1\frac{1}{2}$ " TRANS-TORQUE nut is 125 foot pounds MAXIMUM.

Slide outs with either the center-mounted or end-mounted motors can be moved by pushing the room the full length of its travel in either direction. This method will require the assistance of at least two people.

IMPORTANT

The TRANS-TORQUE bushing must be re-tightened to re-couple the slide out gear motor before moving the coach. This will hold the slide out room in place. The correct torque on the $1\frac{1}{2}$ " TRANS-TORQUE bushing is 110 foot pounds maximum. The correct torque on the $1\frac{1}{2}$ " TRANS-TORQUE bushing of the K-900 motor (center shaft motor) is 125 foot pounds maximum.

Operating Precautions

WARNING

Before extending the slide out, make certain that there is a minimum of five (5) feet of clear space on the slide out side of the unit. Prior to extending the room, be sure to unlock the slide out locking arms.

Before extending the slide out, make sure that the unit is level and that the stabilizing jacks, if available, have been set. Make sure there are no obstructions either inside or outside the unit that may interfere with the slide out extension. Tree branches, bushes, or telephone poles can cause extensive damage to the exterior of the unit.

Notes

CHAPTER 9

EXTERIOR FEATURES

Table of Contents

Exterior Sides	9 - 1
Jacks	9 - 1
Stabilizer Jacks	9 - 2
Roof	9 - 2
Steps	9 - 2

EXTERIOR FEATURES

Exterior Sides

The sides of this unit are constructed of Filon fiberglass with gel-coated fiberglass end caps. This is a standard feature on these models. An optional feature would be to have the sides constructed from gel-coated fiberglass. Clean this material with a mild cleanser and warm water. Use only soft cloths. Using stiff bristle brushes may cause scratches in the surface.

Jacks

Standard on fifth wheel units are the 12 volt electrical front jacks. Before using the jacks, read and closely follow the operation instructions in the jack manufacturer instructions.

Fifth Wheel

To lift the unit for uncoupling, drop the pad tube by removing the lock pin. Re-pin the hole that places the foot pad closest to the ground. Push the toggle switch to the "DOWN" position and hold until the jack raises the unit to the desired height.

CAUTION

Before raising the jacks, make sure the hitch is securely latched by applying the trailer brakes and slowly pulling the tow vehicle forward. The unit should prevent the tow vehicle from moving.

To raise the jacks after coupling, push the toggle switch to the "UP" position and hold until the jacks are fully retracted. Release the toggle switch as the lock pin in the inner ram tube nears the end of the outside tube to avoid unnecessary wear on the motor clutch. Remove the lock pins and raise the pad tubes, re-pinning them in the highest possible position.

CAUTION

When the jacks reach their maximum extended or retracted length or maximum load, you will hear a clicking noise. This is the slip clutch built into the motor to prevent jack overextension or retraction. Release the toggle switch as soon as you hear the clicking. Continued operation with the clutch slipping can damage the jacks.

These jacks can be operated manually, if necessary. Insert the hand crank into the alignment tube until the end engages with the crank shaft. Turn the crank handle counter clockwise to raise the trailer. Remove and store the crank handle. To raise the jacks after coupling, rotate the crank handle clockwise. Retract as far as possible with the crank handle, then remove the lock pin and raise the pad tube and re-pin it in the highest possible position. Please refer to the jack manufacturer Operation Instructions for further assistance.

The snaps for the fifth wheel jacks are a standard feature on this model.

Stabilizer Jacks

This unit is equipped with one pair of stabilizer jacks. The operation of the stabilizer jack is rather simple. First park the vehicle on level ground. Block the wheels using tire chocks to prevent the unit from moving. Level the front and the back of the unit using the tongue jack or landing gear. Crank the stabilizers down on the low side first, this will bring the trailer to a fine level position. Re-tighten the stabilizers on the low side of the unit, if necessary. Do not use stabilizer jacks to lift the unit.

CAUTION

Before moving the trailer, crank up the stabilizer jacks to the fully closed position. Tighten $\frac{1}{4}$ turn to secure the jacks in the travel position. This will help prevent the stabilizers from working open due to road vibration. Do not use stabilizer jacks to lift the unit.

Roof

Standard on this unit is the rubber roof with a roof rack and ladder. The ladder will assist you in gaining access for routine roof inspections.

Steps

The entrance door steps on your unit are triple fold-down steps. Automatic triple steps are an option. To extend the step, first release the locking latch. Once the latch is released, pull the step pivot section out and down by the step cross member bar. NOTE: Be careful not to get any fingers or clothing near the pivot action of the step. Next, release the second step by pulling the step up and straight outward until it locks into position. Then pivot the third and final step out and down. For retracting the step, reverse the procedure. Keep all step pivot points lubricated with a quality grease-based spray lubricant for smooth operation.

Notes

CHAPTER 10

INTERIOR FEATURES

Table of Contents

Bedsread	4	10 - 1
Flooring		10 - 1
Ceiling		10 - 1
Window Treatment		10 - 1

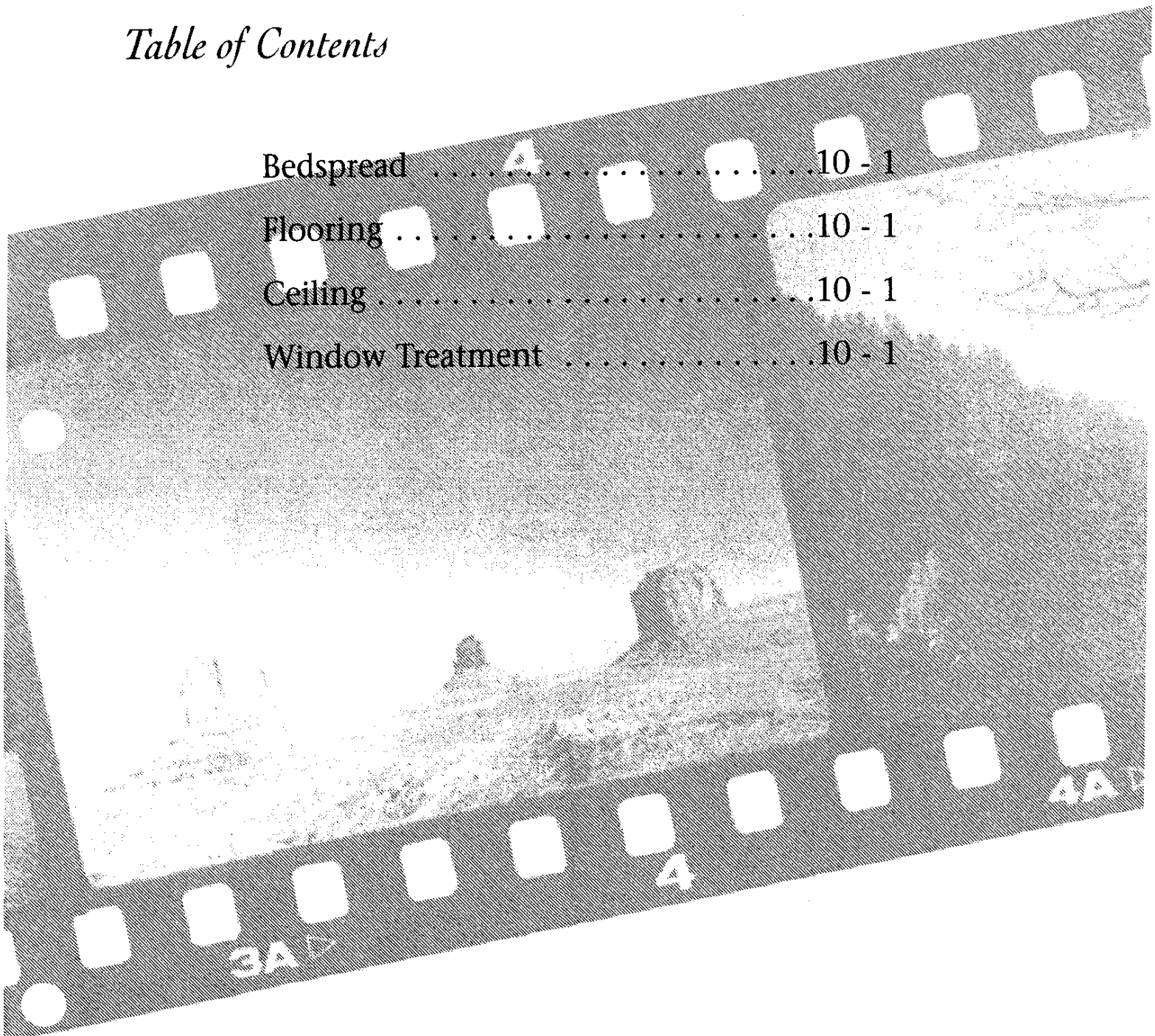

INTERIOR FEATURES

Bedsread

All units have a decor matching fitted bedsread enclosed as part of the standard package. The recommended cleaning instructions for this spread are Dry Clean Only. The materials that make up the spread may have been treated and dry cleaning will preserve this treatment.

Flooring

The floor covering in the living room and bedroom of the unit is carpet. In the owner's information package you will find literature supplied by the carpet manufacturer. This information will be helpful in maintaining and extending the life of the carpet. Please refer to this information for the carpet care and cleaning instructions. The floor covering in the bath, kitchen and foyer area is a vinyl linoleum. The cleaning procedures for this flooring are the same as with any linoleum. Use a mild soap with warm water and a soft cloth or mop. There are two options for the floor covering in the bath, kitchen and foyer area. The options are either the Wilson Art 15" floor tile or simulated plank. This flooring is cleaned the same as linoleum. Do not saturate with water; this could damage the flooring.

Ceiling

The ceiling in this unit is covered with a woven soft touch ceiling covering. The recommended cleaning instructions are to have the ceiling professionally dry cleaned.

Window Treatment

The window treatment throughout this unit, except in the kitchen, is pleated day/night soft shades with lined drapes. These shades have two sections. The first section visible when closing the shade is the "DAY" section. This material is translucent. Sun light passes easily through the material into the unit. The second visible section is the "NIGHT" section. This material is a heavier, more opaque material. Very little to no light passes through it. It is generally used in the evening or when more privacy is desired. The cleaning instructions for the drapes are DRY CLEAN ONLY. The kitchen window is equipped with a mini-blind.

Notes

CHAPTER 11

PLUMBING & BATH FEATURES

Table of Contents

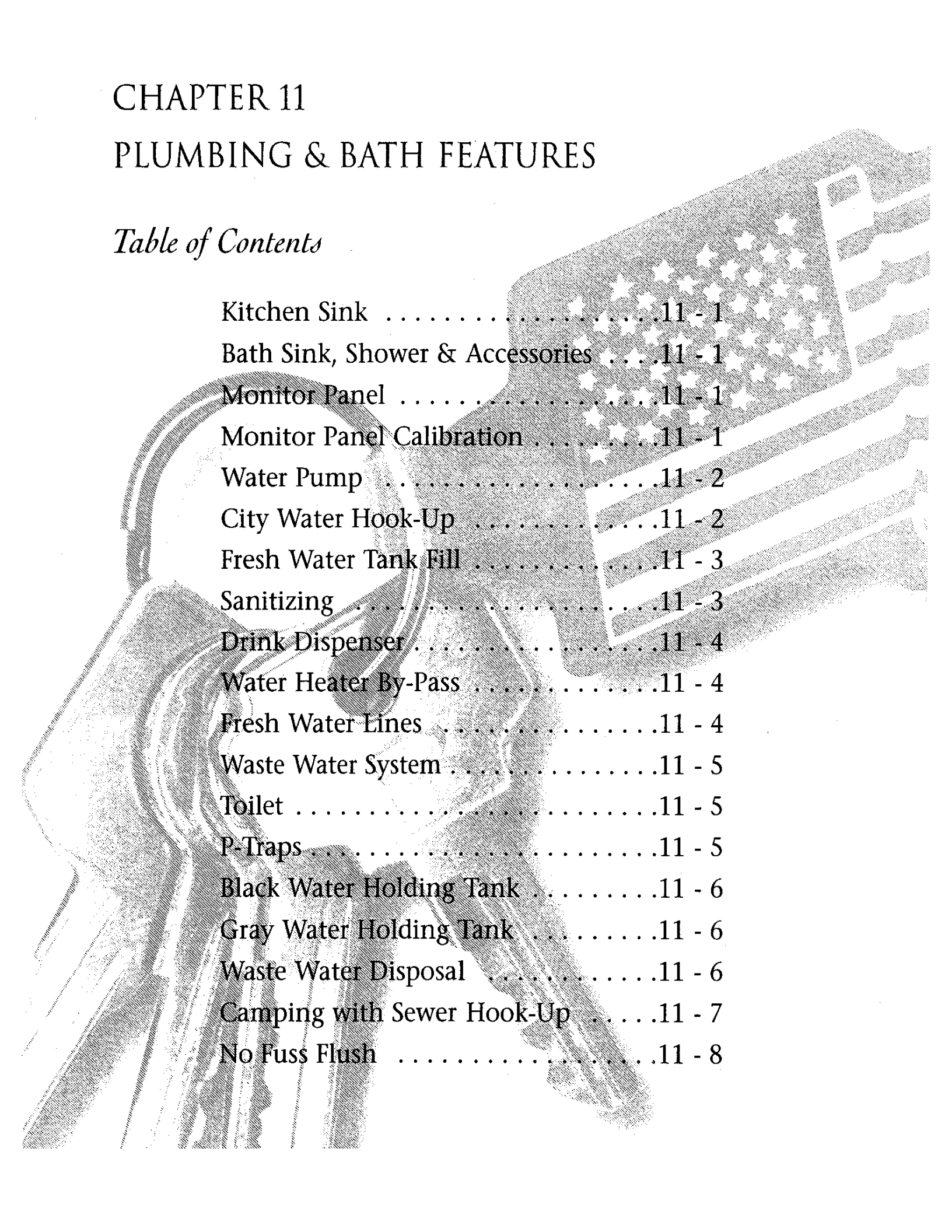

Kitchen Sink11 - 1
Bath Sink, Shower & Accessories11 - 1
Monitor Panel11 - 1
Monitor Panel Calibration11 - 1
Water Pump11 - 2
City Water Hook-Up11 - 2
Fresh Water Tank Fill11 - 3
Sanitizing11 - 3
Drink Dispenser11 - 4
Water Heater By-Pass11 - 4
Fresh Water Lines11 - 4
Waste Water System11 - 5
Toilet11 - 5
P-Traps11 - 5
Black Water Holding Tank11 - 6
Gray Water Holding Tank11 - 6
Waste Water Disposal11 - 6
Camping with Sewer Hook-Up11 - 7
No Fuss Flush11 - 8

FRESH WATER SYSTEM

Kitchen Sink

The kitchen sink installed is a double bowl stainless steel sink. The unit has two sink covers to provide additional counter space when the sink is not in use. Stainless sinks do not rust or chip. Cleaning care consists of washing with mild detergents and a soft cloth. Avoid using "S.O.S." type cleaning pads because they may scratch the stainless steel surface. The faucet in the kitchen is an 8" chrome single-handle faucet with a lavatory spray.

Bath Sink, Shower & Accessories

The sink in the bathroom is vacuum formed durable white plastic. Use care when cleaning to prevent from scratching the surface. The bathroom accessories include two towel bars, a robe hook, and a tissue holder. The faucet in the bathroom a decor matching white dual-handle faucet. The shower installed is an ABS fiberglass tub/shower combination with enclosure. The white tub faucet with shower head, hose and bracket coordinate with the sink faucet. An optional assist handle can be installed in the tub/shower.

Monitor Panel

The monitor panel allows you to check the approximate levels in the fresh, gray, and black water holding tanks, and the battery condition. The monitor panel is generally located in the bathroom. Simply press the button of the item to check its status. The empty indicator light will always light when the button is pressed. If the tank is full, all of the lights will be on. Lights are sequential, and indicate the level in approximately $\frac{1}{4}$ tank increments. For example: If the tank selected is approximately $\frac{1}{2}$ full, then the indicator lights E, $\frac{1}{4}$, and $\frac{1}{2}$ will be lit. On the right-hand side of the monitor panel is the water pump switch. This switch controls the power going to the water pump, turning it either on or off.

Monitor Panel Calibration

The monitor panel comes to you factory calibrated for accuracy and should not need to be adjusted. In the event that the system does not read accurately, then re-calibration may be necessary. The procedure for re-calibration is simple: First, fill the tank to be re-calibrated. Second, using the adjustment tool enclosed in the owner's package (or any small flat-bladed screw driver) simultaneously push the button for that tank and rotate the adjustment screw located above the button and behind the face plate counter-clockwise until some of the lights turn off in sequence. Then slowly rotate the adjustment screw clockwise until the full light is completely on. Repeat this procedure as necessary for the remaining tanks. The system is now calibrated properly.

Water Pump

The water pump is self-priming and totally automatic, operating on demand whenever water is required. The water pump is used to pressurize the fresh water system when the unit is not connected to city water. To start the pump follow these instructions:

1. Fill or partially fill the fresh water supply tank.
2. Open the kitchen and bathroom faucets.
3. Turn the water pump switch on and allow the water to fill the water line and the hot water heater.
4. Close each faucet after it delivers a steady stream of water (close the cold water first). Leave the hot water faucets on until they also deliver a steady stream of water. This will ensure that the water heater is filled with water.
5. The water pump should stop running once all faucets are closed.
6. The pump is now ready for automatic operation. The pump will run when a faucet is opened and stop when a faucet is closed.
7. Never allow the pump to run for long periods of time without water in the supply tank. Pump damage or blown fuses may result.

If water doesn't flow when a faucet is turned on while using the demand system, use the following trouble shooting chart.

SITUATION	SOLUTION
Pump running - no water	1. Fill tank 2. Clear the water line to the pump
Pump doesn't run	1. Check the pump switch 2. Check the 12 volt fuses 3. Check the electrical connections 4. Check the battery

All of the water should be drained from the fresh water system when the unit is not in use for more than one week. For more detailed information regarding the water pump, refer to the water pump manufacturer's brochure in your Owner's Packet.

City Water Hook-Up

When connecting your unit to city water, be certain to use a water hose manufactured and labeled for potable water. This will ensure that the hose will not alter the taste of the water. To hook the city water supply to the unit, connect one end of the hose to the city water supply. This will usually be a faucet or valve similar to your garden hose valve at home.

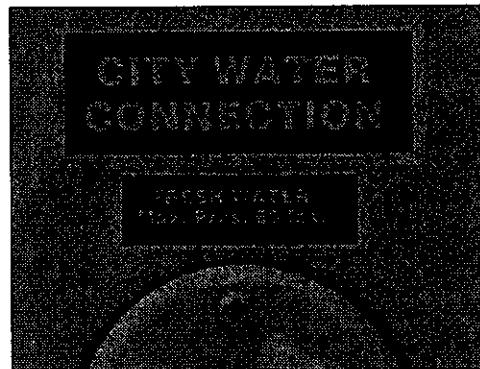

Turn the city water supply on for a few seconds in order to clear the line. Once the hose has been flushed, turn the supply off. Connect the other end of the hose to the city water connections. Turn on the water supply and open all of the faucets to clear the air from the lines in the unit. Once air pockets have been purged from the water lines and water flows freely, close all of the faucets. The city water supply is under pressure, therefore the water pump is not necessary when connected to city water. Once the city water fill valve is opened, water is supplied to the fresh water system including the hot water heater, faucets, and stool. To disconnect from the city water supply, close the valve and remove the hose from the city water supply. Disconnect the hose from the city water connection and store the hose in the water compartment.

Fresh Water Tank Fill

The fresh water tank is filled through the water fill located on the door side of the unit. There are two ways to fill the fresh water tank. One would be with buckets and a funnel. Place the funnel in the water fill port and pour the water from buckets, jugs, etc. The other way would be with a water hose. When filling the tank, be sure to use a water hose manufactured and labeled for potable water. Place the hose in the water fill port and turn the water on. When the tank is full, excess water will flow from the screened vent located below and to the right of the water fill port. All of the water should be drained from the fresh water system when the unit is not in use for more than one week. Whenever possible, drain the fresh water tank before traveling. Water in the tank will reduce the carrying capacity of the unit.

SANITIZING

To assure complete disinfecting of your fresh water system, it is recommended that the following procedure be followed on a new system, on one that has not been used for a length of time, or one that may have become contaminated. This procedure is also recommended before long periods of storage such as over the winter months:

1. Drain the fresh water tank by opening the drain valves. There is one valve per water tank. All of the faucets should be in the closed or off position.
2. Prepare a chlorine solution using one gallon of water and $\frac{1}{4}$ cup of chlorine bleach (5% sodium hypo-chlorite solution). Prepare enough of the chlorine solution to administer one gallon of solution for every 15 gallons of tank capacity. For sanitizing this unit, prepare 3 gallons of the chlorine solution. This mixture puts a 50 PPM (parts per million) residual chlorine concentration in the water system that will act as a quick kill dosage for harmful bacteria, viruses and slime forming organisms. Concentrations higher than 50 PPM may damage the water lines and/or tank.
3. Once the fresh water tank is empty, close the drain valves on the water tank. Pour the chlorine solution into the tank when the fresh water tank is empty. This is done by placing a funnel in the fresh water port and pouring in the chlorine solution. Once the solution is in the tank, completely fill the fresh water tank with water.
4. Open each faucet in turn including the kitchen faucet, bath faucet, inside and outside shower, turning on both the hot and cold, and flushing the stool until all of the air has been purged from the pipes and the water runs freely. The entire system will then be filled with the sanitizing solution.

5. Allow the 50 PPM disinfecting solution to stand in the system at least four hours.
6. Drain the system and flush with fresh water. The water system needs to be flushed with clean water repeatedly, if necessary, until there is no chlorine taste or smell left in the system. To remove any excessive chlorine taste or odor that might remain, prepare a solution of one quart vinegar to five gallons of water. Allow this solution to agitate in the tank for several days by vehicle motion. Drain the solution and refill the tank with clean water.

Drink Dispenser with Water Filter (Optional)

Before disinfecting the fresh water system, remove the water filter and install the by-pass pipe to allow water access to the drink dispenser faucet if installed. The water filter is located under the kitchen sink. The filter will remove chlorine, dirt, and other matter. It will also eliminate most phenol (or similar) odors and tastes while delivering sparkling, taste free water for drinking and cooking. The filter is connected only to the cold water line that is attached to the drink faucet. The filter is not guaranteed to remove the tastes and odors of iron and sulfur. To remove these tastes you will need to chlorinate the water. Replacement filters are available that will filter iron and sulfur. Ask your dealer or RV supply center about acquiring an iron and sulfur filter. If you are traveling in an area where the water has a high iron and sulfur content, then add 1 tablespoon of chlorine bleach to every 10 gallons of water in your tank. This will precipitate the iron or sulfur so that the filter can remove it. If you are at a site where the unit is hooked up to city water, you will not be able to chlorinate the system because the water flows straight to your faucets and not through the fresh water tank. Filters should be changed every 6 - 12 months depending on the quality and quantity of water that is used in your unit.

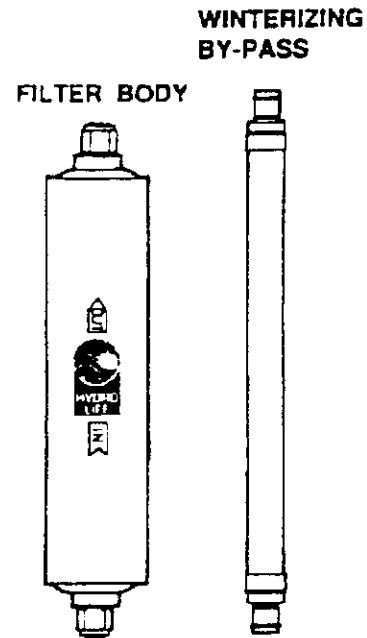

Water Heater By-Pass System

The water heater by-pass valve is located at or near the water heater. By closing the water heater supply valve and opening the by-pass valve you can divert water away from the water heater. This is done when winterizing your unit. Using the by-pass will keep antifreeze out of the water heater when winterizing the system.

Fresh Water Lines

Vibration and flexing during traveling can cause pipes and fittings to work loose. Check all of the plumbing connections for leaks on a yearly basis. If the water pump runs when all faucets are turned off, check for a leak. Be sure the drain valves are closed. Connections at the kitchen and bathroom faucets normally seal with hand tightening and a half turn with a wrench. If a fitting leak persists, disconnect it completely and check for mineral deposits or

foreign material on the sealing surfaces. Clean the surfaces thoroughly and reinstall the fitting. Take the coach to an authorized service center for repairs if the system continues to leak. Follow the winterizing instructions given in Chapter 14 to reduce the risk of leaks caused by cracks from freezing pipes. Freezing damage can be extensive and expensive.

WASTE WATER SYSTEM

General Information

The waste drainage system was designed to provide adequate and safe storage and/or disposal of waste materials. All of the material used in the making of this system are tested by a nationally recognized testing laboratory. The drainage system uses ABS plastic piping and fittings connected to the sinks, toilet, and holding tanks. This provides for their drainage to an outside termination. The unit should be reasonably level for best operation of the system. There are two separate waste systems. The gray water system is for waste water from the sinks and shower. The black water system is generally for sewage waste from the stool. Each tank has its own control valve and both tanks drain through the sewer drain hose.

Toilet

The stool operates with water from either the fresh water tank with the water pump on or the city water supply. Before using the stool, add water to the bottom of the tank. Refer to the "BLACK WATER TANK" instructions in this chapter. The stool flushes wastes directly into the black water holding tank. The stool uses high velocity water injection to produce a swirl effect in the bowl. The greatest problem that causes stool solids to build up in the holding tank is lack of liquids. When using your stool, it is wise to fill the stool 3/4 full of water. This will help to wash the solids away from directly below the stool and to ensure complete dumping of the holding tank. Depending upon the model installed, water can be added to the stool bowl by lifting up on the lever. To flush the stool, push down on the lever until water swirls.

The stool requires little maintenance. Use an approved non-abrasive cleaner to clean the bowl. Spraying the bowl sealing blade with a silicone spray will retain the original smooth operating condition.

Check the complete instruction and trouble shooting guide in the stool manufacturer's owner's manual provided in the owner's package.

P-Traps

Each of the sink drains, the shower drain, and the washing machine drain (if equipped) has a water trap (P-Trap) to prevent holding tank odors from entering the coach. These traps must have water in them in order to work. While traveling, the water may splash out of the sink and shower drains. While stored, the water may evaporate allowing an odor to enter the coach. If this occurs, run water from the faucet into the drain, allowing water to fill the trap.

Black Water Holding Tank

The black water, or sewage, holding tank is located directly beneath the toilet. Before using the stool, you will need to treat the tank with water that is mixed with an odor controlling chemical. These chemicals are readily available at any RV supply store. Be careful not to spill the chemical on your hands, clothing or the carpet because it may cause a permanent stain. Pull the toilet levers forward to allow the chemical to mix with the toilet water. Continue pulling the toilet levers until at least one inch of solution is directly under the toilet. Release the levers and the waste tank is ready for use.

CAUTION

Use only approved RV odor controlling chemicals in the holding tanks. Products containing ammonia and petroleum will damage the ABS plastic holding tanks and seals.

Gray Water Holding Tank

The gray water holding tank is located in the underbelly of the unit. It is primarily used for the drainage from the kitchen and bath sinks and the shower.

Waste Water Disposal

Both of the holding tanks terminate in a valve arrangement that permits draining each tank separately or together. It is recommended to drain the black water tank before the gray water tank. This will allow the water from the gray tank to wash the black water residue from the drain lines and hose. The valves that open to release the water are called gate valves. The blade that closed the opening in the sewer drain pipes is connected to the T-handle to release the contents of the tank(s) when pulled. The sewer line must be securely capped during self-containment use to prevent leakage of waste material onto the ground or pavement. Do not pull the holding tank gate valve open when the protective cap is installed on the pipe. Always drain the tank into an acceptable sewer inlet or dump station.

WARNING

Holding tanks are an enclosed sewer system and must be drained into an approved dump station. Both black and gray water holding tanks must be drained and rinsed thoroughly on a regular basis in order to prevent the accumulation of harmful or toxic materials.

Whenever possible, drain the holding tanks prior to traveling. The carrying capacity of your unit will be reduced if water is left in the black or gray tanks.

The holding tanks should only be drained when they are at least $\frac{3}{4}$ full. Doing this will provide sufficient water to allow the complete flushing of waste materials in the drain lines and hose. If the tanks are not $\frac{3}{4}$ full, add enough water to allow for sufficient flushing.

To empty the waste water tanks, connect the adapter to the drain hose. Use the adapter supplied with your unit. If the adapter is lost or broken, one can be purchased from most RV supply stores. Once you have placed the adapter on the drain hose, it can remain there for the life of the hose. Unscrew the cap off the drain. Connect the hose with the adapter in place to the drain fitting. Open the gate valve all the way by pulling on the T-handle. The tank will start to drain as soon as the T-handle is pulled. After you have drained the black water tank, immediately drain the gray water tank. Doing this helps to flush the black water from the sewage hose.

When both of the tanks are empty, flush them with a fresh water rinse before you close the valves. The gray tanks are easily flushed by pouring a couple of gallons of water into a sink drain. Prime the system with an odor control chemical following the directions above for preparing the system for use. The drain outlet is engineered for quick release of the drain hose adapter. Always close the gate valves and secure the end cap to prevent leakage while in transit. After draining, add enough water to the black water tank to cover the bottom.

When using dump stations for draining the holding tanks, keep other travelers in mind. Practice good housekeeping. Leave the dump stations in good order. Above all, do not pollute.

Camping with Sewer Hook-Up

When camping at parks with sewer hook-up, it is important to keep the black water holding tank gate valve closed at all times, except when dumping. The gray tank can be kept open while hooked to a sewer connection but again, the black water tank must be kept closed. This is done so that an ample supply of liquid remains in the tank to provide a smooth flow through the gate and drain valve when dumping. Sufficient liquid in the tank causes a swirling action that should take any accumulated solid wastes with it. Accumulation of solid wastes in the black water tank can be avoided by keeping the gate valve closed when connected to the sewer hook-up. If the valve is left open, solid wastes may accumulate in the tank. This may eventually result in costly repairs. The gray tank valve needs to be in the open position when operating the optional washing machine.

Notes

No Fuss Flush

This unit may be equipped with an flushing system for the holding tanks. When draining your sewer tank, attach a water hose to the Sewer Spray hookup. After the tank is drained, leave the gate valve open and open the water valve to allow water to spray inside the sewage tank. This will clean the inside of the tank of any debris that may be left inside the tank. After this is done, disconnect the water hose and close the gate valve. When unsure if any solids are still left inside the tank, fill the sewage tank with approximately ten gallons of water through the stool. Then, as you travel, the agitation of the water should help liquefy any solids left in the tank. You can dump the sewage tank again at your next destination.

CAUTION

Do not use the same hose for the No Fuss Flush that is used for filling the fresh water tank.

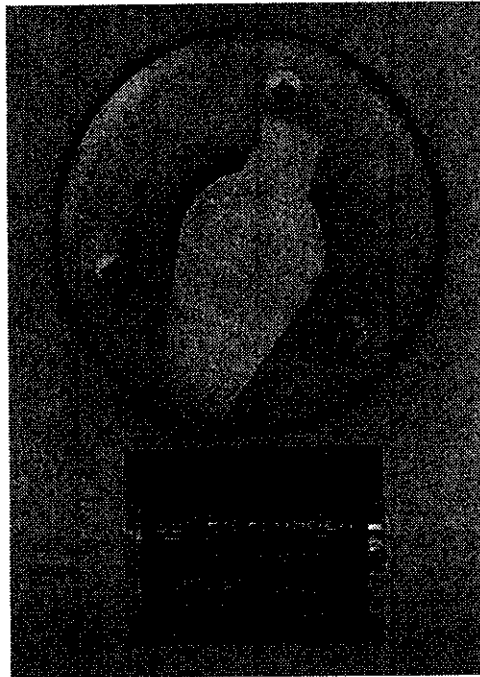

Notes

CHAPTER 12

CONSTRUCTION FEATURES

Table of Contents

Construction Features12 - 1

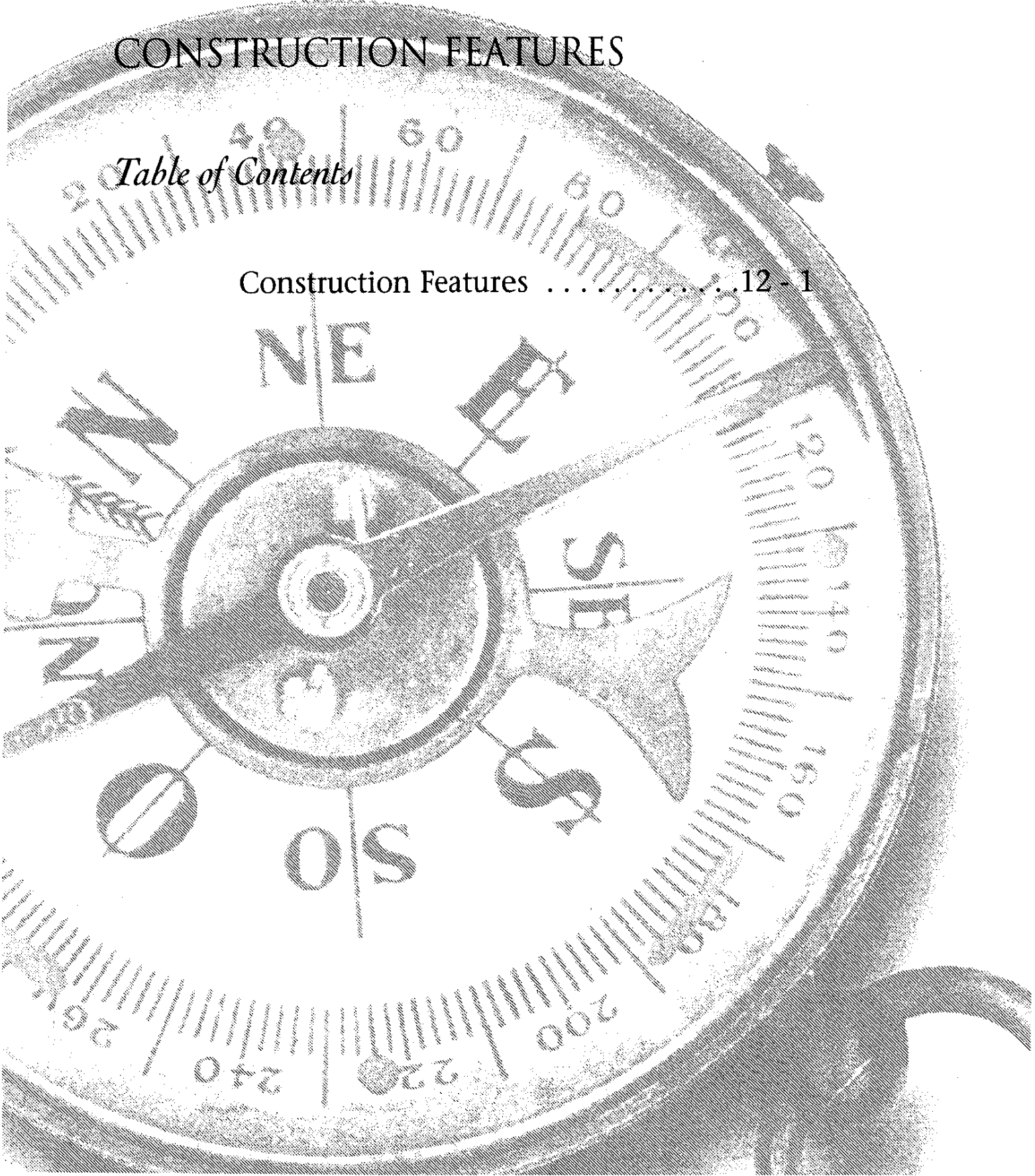

CONSTRUCTION FEATURES

The floor decking is constructed of durable 19/32" structure wood. The fiberglass insulation in the floor and roof is rated at R19. The fiberglass insulation in the sidewalls is rated at R7. The insulated underbelly is enclosed with fiberglass. The rear bumper pulls out with a slide-out tray for the storage of the standard spare tire.

On this model, each sidewall is constructed for strength and is heavily insulated for comfort. Welded, for added strength, the extruded aluminum sidewalls and roof are built with 16" on center framing, providing the strongest and most durable construction. The inside consists of 5/8" beaded foam that is laminated to kraft paper and covered by the interior paneling. A blanket of rolled insulation is added to the sidewalls, roof, and slide out to provide a greater efficiency and consistency of climate control. In addition, under the exterior roof is a layer of 1/4" foam board insulation. This will assist the furnace in the winter by keeping the warm in and the cold out. In the summer months, it will assist the air conditioning by keeping the cool air in and the hot air out.

Below are examples of the framing and insulation that your unit is constructed with.

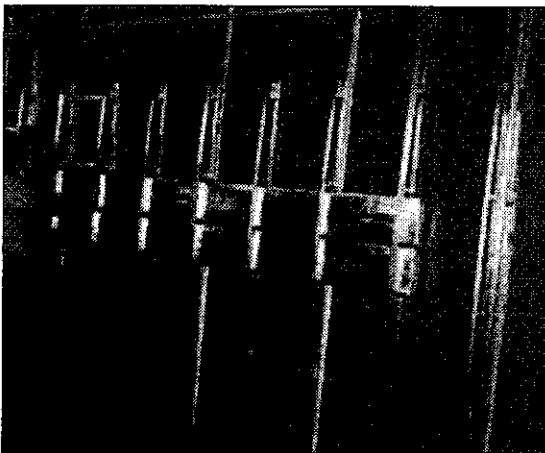

Notes

CHAPTER 13

WINDOWS, AWNINGS, VENTS & DOORS

Table of Contents

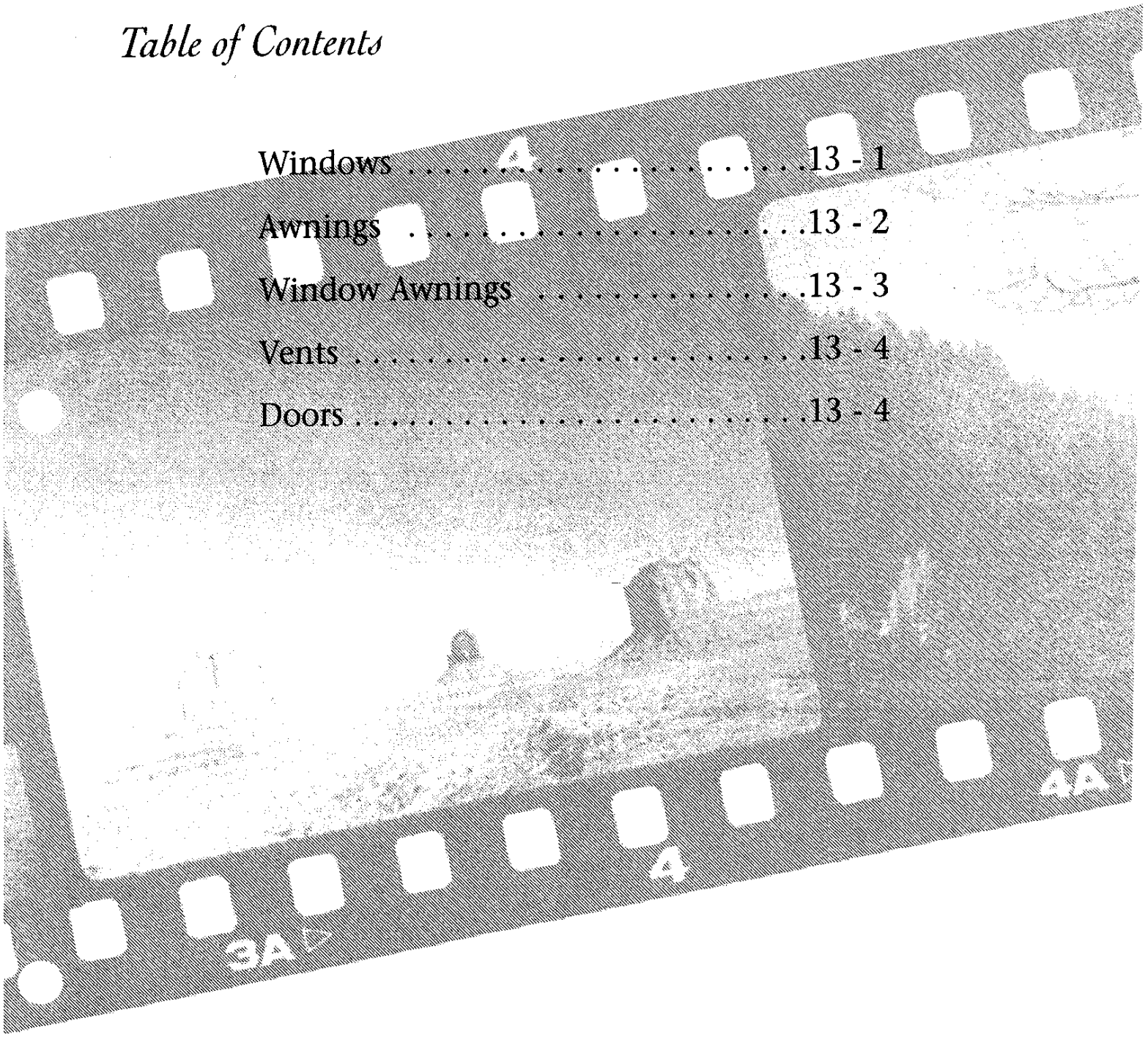

Windows	13 - 1
Awnings	13 - 2
Window Awnings	13 - 3
Vents	13 - 4
Doors	13 - 4

AWNINGS

Side Awning

A side awning is installed on your coach. The side tension rafter can also be optioned. To operate, follow these instructions:

EXTENDING

1. Loosen the black adjustment lock knob behind each main arm. Flip the travel lock latches up.
2. Using the provided pull rod, reach up and pull the locking lever forward or down to release the awning.
3. Hook the rod into the loop of the pull strap and pull the awning all the way out.
4. Slide one rafter arm up until it snaps into place. Push down on the main arm to remove slack from the fabric, and tighten the black adjustment knob. Repeat on other side.
5. Slide the pull strap to the right end of the roller and wrap it around the main arm.
6. Pull up on the lift handle and raise the arm assembly to the desired height. Swing handle in, and allow the lock button to snap into one of the holes. Repeat on the other side.
7. Press the release lever at the bottom end of one main arm, pull the arm assembly outward to a vertical position, and readjust height. Repeat on other side. Drive provided stakes through holes of each patio foot into the ground.
8. During rain, lower one end to allow water to flow off.

CAUTION

Whenever heavy or prolonged rain or wind is anticipated, or you will leave the awning unattended, it is best to close the awning. Damage as a result of weather is not covered by warranty.

RETRACTING

1. Pull the stakes from the ground, swing the arm toward the vehicle, and snap the patio foot into the bracket. Repeat on the other side.
2. Raise the lift handle to release the lock button. Lower the main arm to the stop plug. Swing the handle in to engage the lock button in a hole. Repeat on other side.
3. Loosen black adjustment knob, lift slider catch, and slide the rafter arm down to the bottom of the main arm. Leave the black adjustment knob loose. Repeat on other side.
4. Grasp the pull strap and pull toward you. Flip the locking lever to the ROLL UP position. Hold the awning in the down position until you are ready to roll up the awning.

CAUTION

The awning will try to roll up as soon as the locking lever is flipped to the "ROLL UP" position.

5. Slide the pull strap to the center and using it to control speed, allow the awning to return to the side of the vehicle. Allow the strap to wind diagonally to prevent a bulge in the fabric.
6. Tighten the black adjustment knob and flip the travel lock latch down. Repeat on other side. The awning is now ready for travel.

Window Awnings (Optional)

Optional on this unit are the matching window awnings for the bedroom and the slide out room windows. To operate these, use the following instructions:

EXTENDING

1. Grasp the loop on the pull strap and pull down to extend the awning. Then hook the loop onto the window strap hanger.

RETRACTING

1. Remove loop on the pull strap from the window strap hanger.

CAUTION

Do not release the strap as the window awning is under tension and may snap back against the vehicle.

2. Slowly allow the awning to roll back to the closed position by feeding the pull strap upwards and diagonally. This prevents the strap from building up and creating a bulge in the fabric.
3. The window awning is now ready for travel with no further locking required.

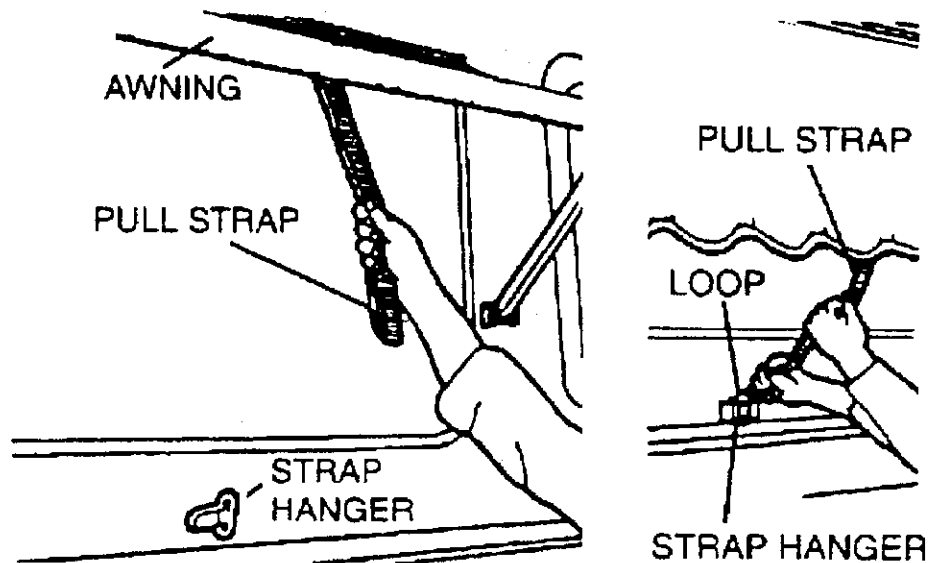

Vents

There is one standard vent in the unit. It is located in the bath area. This vent operates on 12 volt electricity. The vent is controlled by an on/off switch on the wall. A possible option would be the installation of a 12 volt Fantastic Vent with rain sensor. This vent is controlled by the wall thermostat. When on, it will run until the desired temperature is reached. If, while the unit is on, it starts to rain, the sensor will automatically shut the unit off and the vent cap on the roof will close.

An optional vent of this style may have been added at time of production.

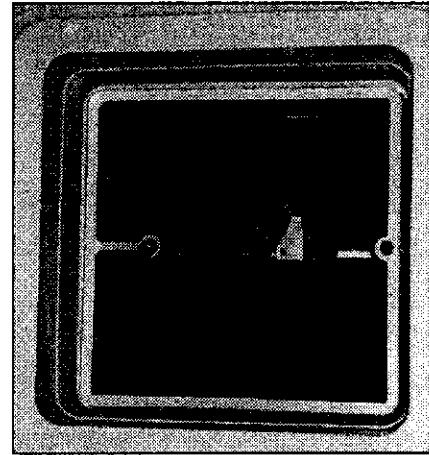

An optional skylight is available in the bathroom. If installed, this will be located above the tub/shower.

In the kitchen, a possible option would be the installation of a 12 volt Fantastic Vent with rain sensor. This vent is controlled by the wall thermostat. When on, it will run until the desired temperature is reached. If, while the unit is on, it starts to rain, the sensor will automatically shut the unit off and the vent cap on the roof will close.



Doors

The entrance door is a radius door with a dead bolt lock for added security. The door can be held open with the door stop. With the door open, simply lift the "T" section on the door and place it in the holder on the exterior sidewall of the unit. Next to the entrance door you will find the standard lighted acrylic assist handle. This handle will assist anyone entering the unit.

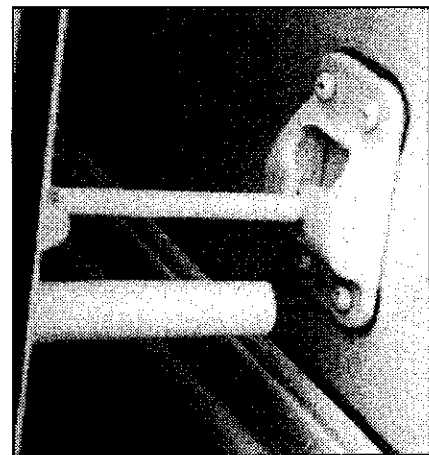

CHAPTER 14

ROUTINE MAINTENANCE

Table of Contents

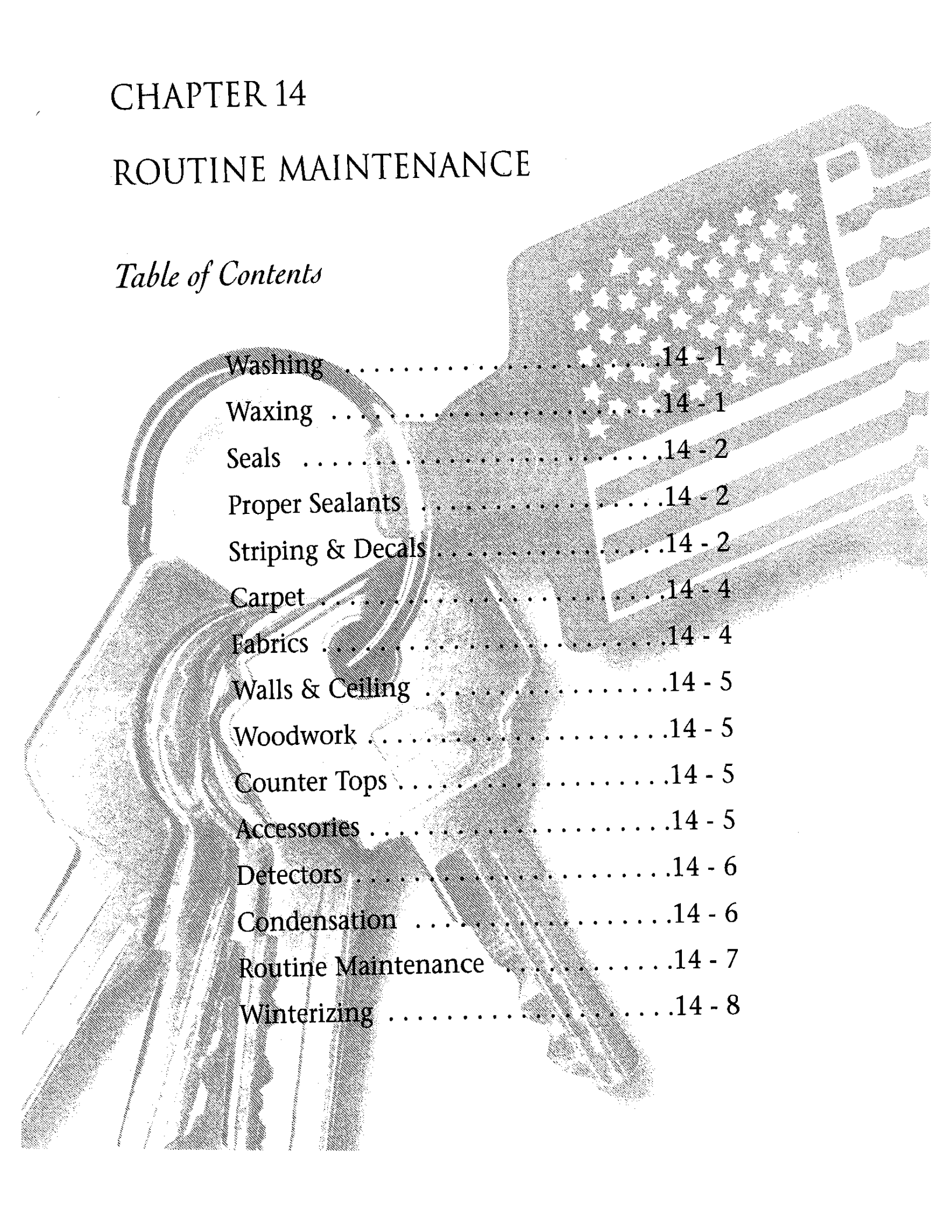

Washing	14 - 1
Waxing	14 - 1
Seals	14 - 2
Proper Sealants	14 - 2
Striping & Decals	14 - 2
Carpet	14 - 4
Fabrics	14 - 4
Walls & Ceiling	14 - 5
Woodwork	14 - 5
Counter Tops	14 - 5
Accessories	14 - 5
Detectors	14 - 6
Condensation	14 - 6
Routine Maintenance	14 - 7
Winterizing	14 - 8

EXTERIOR CARE

IMPORTANT

Damage caused by improper or unapplied maintenance is not covered by your Newmar Limited Warranty.

Washing

The exterior of your new camping vehicle is made of pre-finished aluminum and/or fiberglass. Frequent washings and thorough cleanings are required to prevent damage to the vehicle finish after exposure due to damaging salts, calcium chloride, road tar, tree sap, insects and other foreign material. Damage caused by exposure to these items is not covered by your Newmar Limited Warranty. Never wash the vehicle in direct sunlight, while the vehicle is hot or with hot water. Build up of mud and dirt under the body can cause damaging rust on steel parts. Corrosive materials, such as those used for ice and snow removal and dust control, also accumulate on the underside of the vehicle. These materials should be removed by spraying the underbelly regularly with water, especially areas where mud and other foreign materials collect. The chance of corrosion can be minimized by frequent washings of the vehicle. When washing the vehicle, make certain that the undercarriage and the wheel wells are cleaned, as well as the exterior of the coach. Do not use strong soaps or detergents for washing the vehicle. Always use a mild soap in warm water, a commercially prepared product for automotive finishes or your local car wash. Be careful when using a pressure-type washer to avoid loosening any exterior decals or sealants, etc. After washing, carefully inspect the caulking around window frames and vents and any other joints that may have separated. Recaulking, if necessary, is relatively simple, and is considered routine maintenance which is the responsibility of the owner.

IMPORTANT

Never use a strong solvent, such as lacquer thinner, or harsh abrasives, on any of the exterior painted surfaces.

Waxing

The exterior finish will require a routine waxing. When water will not bead and roll off a freshly washed vehicle, a new coat of wax is needed. Wax not only improves the appearance of the vehicle, but it also protects the finish against oxidation and corrosive materials. The recommended type of wax is one that is compatible with painted or gel-coated fiberglass finishes, and contains a UV (ultra-violet) inhibitor. Buffing with a polishing compound will improve a dull or discolored finish.

IMPORTANT

When using a polishing compound that does not contain a wax preservative, reapplying a coat of hard wax after polishing is recommended.

Seals

The seals around doors, windows, vents, slide out trim and external seams should be checked at least twice a year. In addition, the roof seams should be inspected twice a year for cracking or peeling. If deterioration is noted during a routine maintenance inspection, reseal the seams or seals with an approved sealant to prevent leaks. Your dealer can perform the resealing inspections and work for you. Your dealer can perform the resealing inspections and work for you. It is recommended that a Newmar Authorized Service Center perform these inspections and reseal when necessary.

Proper Sealants for Application

Plas-T-Cote	Metal or fiberglass roof
Surebond #SB-140	All Skylights
Carlisle #502-LSW Self Leveling Sealant	Rubber roof
Silicone Sealant	To cover butyl and other sealants, not to be used as the main sealant
Parbond	To seal across tops of windows, etc. on exterior where silicone is not used

Striping & Decals

The striping and decals on your vehicle require little maintenance. Treat these as you would any painted surface on your vehicle. Wash them with mild soap and warm water, or any retail car soap. Never wash the vehicle in direct sunlight, while the vehicle is hot or with hot water. Rinse thoroughly to prevent soap residue accumulation. Use caution with high pressure wash nozzles. Keep them at least 18 inches from the edge of the decals. High pressure water may cause the decal to loosen and peel. Test small sections of decals when using any type of cleaning solution.

IMPORTANT

Do not use solvents such as acetone, MEK, toluene, etc. on the decals. Any solvent including alcohol may soften or smear colors. Do not use lacquer thinner or paint on decals. Do not overcoat the decals with clear paint. Do not allow gasoline or other fuels to drip or stay on the decals for any length of time. If this occurs, immediately flush the area with water.

Rubber Roof Care & Maintenance

Proper care and maintenance of your recreational vehicle, including your rubber roof, is important for trouble-free performance. Normal maintenance is simple and easy, and does not require special materials.

Keep the roof clean. Clean the roof at least four (4) times annually. For normal cleaning:

1. Use a mild laundry detergent. ZEP – Formula 50 Heavy Duty All Purpose Cleaner and Degreaser is the recommended cleaner. Do not use general purpose cleaners containing petroleum solvents, harsh abrasives or citric-based cleaners.
2. Rinse the complete roof with clean water to remove any loose dirt or debris.
3. Using a medium bristle brush, along with your selected cleaner mixed with water, scrub the entire roof. Rinse thoroughly with clean water to avoid residue build up on the roof or sidewall of the vehicle.
4. For more difficult stains, you may use cleaning materials mentioned above in a more concentrated mixture. For stubborn stains, use a rag dampened with mineral spirits is recommended. DO NOT use mineral spirits in a large area or allow it to soak in the roof membrane. Household bleach can also be used (fully concentrated) and allowed to soak in stubborn stain areas, then scrubbed with a medium bristle brush or rag. Rinse thoroughly.

WARNING

Use caution when working on top of your vehicle. The wet roof membrane may be extremely slippery.

Notes

INTERIOR CARE

WARNING

Urea-formaldehyde is used in the productions of particle board, hardwood plywood, and most paneling. Urea-formaldehyde resin may release formaldehyde vapors into the air, which may cause headaches, and in some people, eye, nose and throat irritation. Formaldehyde may intensify some allergies or upper respiratory problems like asthma. Proper ventilation should reduce the risk of such problems.

IMPORTANT

The fading of upholstery, carpet and other interior fabrics is generally caused by excessive sunlight. The drapes, blinds or shades should be kept closed when the vehicle is parked for an extended period of time to minimize the fading. Normal deterioration of appearance items due to wear and/or exposure is not covered by the Newmar Limited Warranty.

Carpet

A weekly routine of vacuuming the carpet and fabrics, throughout the vehicle is recommended. Doing this will prevent an accumulation of dirt that can detract from the materials appearance and shorten its life.

Included in the Owner's Information Package is the carpet manufacturer's Carpet Care Guide. The Carpet Care Guide lists detailed information on cleaning soiled areas and removing stains from the carpet installed in the unit.

Fabrics

The fabrics used in this unit for the bedspread, draperies, headboard and valances may contain fire-retardant additives that can be damaged by use of improper cleaning products. The cleaning instructions for these fabrics are DRY CLEAN ONLY. **Water-based products are not recommended for cleaning the fabrics in your new unit.** Most water-based household cleaning products are not formulated for use on these fabrics and may cause excessive shrinkage or fading. Always test any cleaning product on a hidden area of fabric before using on visible areas. For best results, the fabrics in this unit should be cleaned by a professional carpet and upholstery cleaner.

Spills, spots or stains should be treated as soon as possible to avoid permanent damage. If a spill occurs, blot the fluid with a dry towel. Do not rub the spill. Rubbing may cause the liquid to "set" in the fabric. When attempting to clean a spot or stain, always start from the outside and work inward to avoid spreading it further. Some stains or soils are extremely difficult or impossible to be removed completely. These should receive immediate professional attention. Spills, spots, stains or soils are the responsibility of the owner and are not covered by the Newmar Limited Warranty.

WARNING

When cleaning the upholstery and fabric in the unit, do not use lacquer thinner, nail polish remover, laundry soaps or bleach. Never use carbon tetrachloride or gasoline for cleaning purposes. These items may cause damage to the materials being cleaned and most are highly flammable.

Wall & Ceiling

The wall and ceiling coverings should be cleaned periodically to maintain a new appearance. Use a non-abrasive cleaner with a soft cloth. Do not use solvents of any kind. Solvents may damage the surface.

Woodwork

The wood cabinetry should be cared for with furniture polish to sustain the natural beauty and luster of the wood. This will also keep your cabinetry looking new, and prevent the wood from drying. The simulated plank flooring should be protected from dents, scratches and nicks by installing protective pads on the bottom of chairs and tables. Use of area rugs and floor mats by the entrance door is recommended to trap dirt. To clean the flooring, begin by vacuuming the floor to remove loose dust and dirt. Then, damp mop the floor with one ounce of Wilsonart Flooring Cleaner diluted in one gallon of clean, warm water (or use a non-abrasive, soap-free cleaner). The mop should be damp, not dripping. Do not use soap-based cleaners, scouring powders, steel wool, abrasive cleaners, wax or polish on the floor. To remove stubborn spots like shoe polish, oil, tar, markers, scuff, etc., use a household solvent, acetone or nail polish remover then wipe with a damp cloth. To remove chocolate, grease, juice or wine, use warm water and a non-abrasive cleaner. To remove candle wax or chewing gum, carefully scrape off when the material has hardened. For further tips, please see the manufacturer's information sheet in your Owner's Information Packet.

Counter Tops

To properly care for the Corian counter top in your new unit, always use a heat pad or trivet to protect the surface from hot objects that may mar or damage the surface. Wipe the counter top with a damp cloth to remove water spots. For most dirt and stains, wipe with soapy water or ammonia-based cleaners. For watermarks wipe with a damp cloth, then towel dry. Occasionally, disinfect by wiping the surface with diluted household bleach (one part water/one part bleach).

Accessories

The brass light fixtures, bath accessories and faucets can be cleaned by wiping with a soft, damp cloth. Washing with warm water will remove dry water spots. Do not use cleaners that contain harsh or abrasive chemicals. Alcohol or similar solvents should never be used.

Detectors

The LP detector is self-contained and DOES NOT require any maintenance other than normal cleaning and dusting. When cleaning the exterior of the case use a damp cloth or paper towel. Do not spray cleaners or wax directly into the case as it may cause false alarms.

Condensation

IMPORTANT		
Since surface condensation within the coach cannot be controlled by the manufacturer, damage caused by condensation is not covered by your Newmar Limited Warranty.		

Damage may occur to your unit if excessive condensation exists. Accumulation of condensation on surfaces within your unit occurs when warm, moist air contacts a cool surface. It is most evident on the inside of windows. This problem can be controlled by:

1. Slightly opening a window or roof vent to allow the moisture to escape from the unit.
 2. A small dehumidifier is also very effective in removing moisture from the air.
- Condensation levels are highest during times when a person is cooking or taking a shower in the unit, but these are not the only times condensation is present.
 - Condensation can migrate through ceiling panels and saturate the fiberglass insulation in your ceiling cavity. This condition often causes the occupants to believe the recreational vehicle has a roof leak. Walls and ceiling panels may also become wet when the moisture accumulates on these surfaces.
 - Newmar Corporation does not recommend the use of un-vented catalytic heaters.

Notes

ROUTINE MAINTENANCE

All routine maintenance is the responsibility of the owner and is not covered by the Newmar Limited Warranty. Use the maintenance record found in Chapter 15 to record all performed maintenance as required. Please note that damage caused by improper or unapplied maintenance is not covered by the Newmar Limited Warranty.

Items supplied by other manufacturers may require specific individual maintenance not listed herein. Please refer to the manufacturers' suggested maintenance guidelines in the Owner's Information Packet.

IMPORTANT

Cosmetic adjustments and alignments must be performed within the first three (3) months from date of original purchase for warranty consideration. Thereafter, these items are considered routine maintenance.

Every Trip

- Check brake operation prior to towing.
- Check the tire pressure of all tires.
- Torque all wheel lug nuts.

Every Three (3) Months

- Clean exhaust fan filter and blades.
- Test smoke alarm and LP gas detector.
- Check operation of windows, latches and hinges.
- Clean the roof-ducted air conditioner filter(s).
- Clean and inspect all door and window seals, reseal when necessary.
- Inspect and reseal around the tub and shower area, when necessary.
- Lubricate the exterior door hinges and latches with a graphite (silicone) lubricant.
- Check, clean and tighten battery cables and inspect battery for proper fluid level.

Every Six (6) Months

- Inspect the slide out for proper seal. If realignment is necessary, please contact an Authorized Newmar Service Center.
- Inspect the exterior rubber slide out seals and apply a UV inhibitor, such as 303 Protectant.
- Rotate tires, as recommended by the tire manufacturer.
- Check all gas appliances for proper operation.
- Have the LP system inspected by a qualified technician.
- Lubricate the moveable parts on the entrance step.
- Check the wheels and nuts for cracks, and check the torque of the lug nuts.

Annually

- Inspection of roof seams and joints should be performed by an Authorized Newmar Service Center. If resealing is necessary, it is the owner's responsibility and is not covered by the Newmar Limited Warranty.
- Sanitize the fresh water system.
- Have the axle bearings re-packed, wheel seals replaced and brakes inspected.
- Wax the vehicle as previously described in this chapter.

Winterizing

To store your unit for the winter months, it is necessary to winterize the water system to help prevent freezing. To do this, follow these instructions:

1. The water heater must remain off during this process. Shut off the water pump and make sure the water supply valves are closed. Disconnect the city water fill.
2. To drain the fresh water tank, open the drain valves.
3. Open the low point drain valves. There is one drain valve for each water line, one cold and one hot. This is done to drain all of the water out of the system.

4. After the water heater has cooled off, remove the drain plug to drain the water from the water heater. In the exterior compartment beside the water heater there are two water heater shut off valves and a by-pass valve. The shut off valves must be closed and the by-pass valve must be open, prior to winterizing to prevent the antifreeze solution from entering the water heater.

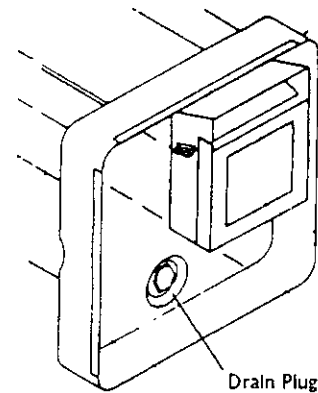

5. Close the low point drains to prevent the antifreeze from draining through the lines onto the ground.
6. Close the water supply valve that flows from the pump to the tank. Remove the water filter, if installed. (See Chapter 11 for more information.)
7. Use only non-toxic antifreeze that has been approved for use in drinking/potable water systems. Place the in-take hose into the antifreeze supply. Open the antifreeze valve to allow the solution to flow freely. Once the water pump is turned on, proceed to the kitchen faucet, bath faucet, inside and outside shower, turning on the hot and cold, and flushing the stool until the antifreeze solution flows freely. If the unit is equipped with a washer, be certain to purge the air from it also. This forces the antifreeze through all of the water lines and faucets. It also allows the antifreeze solution to enter the drain lines and prevent the P-traps from freezing. Check the antifreeze solution from time to time to make sure there is an adequate supply.
8. Close the antifreeze valve when the winterizing process is complete. Store the in-take hose and turn the water pump off.

9. Open the water supply valve that flows from the pump to the tank to help prevent freezing on that water line.
10. To de-winterize your unit, open both of the low point drains to allow the antifreeze solution to drain from the water system. Next, close the low point drains and connect your unit to city water. Put water in the fresh water tank and pump at least one gallon through the water pump in order to remove the antifreeze from the water pump. Keep the water heater supply valve closed and the water heater bypass valves open. The supply valve for the fresh water tank from the pump must remain closed. As in winterizing, open the kitchen faucet, bath faucet, inside and outside shower, turning on both the hot and the cold, and flushing the stool until the antifreeze solution is flushed out of the system and the water flows clear. Once the system has been flushed, open the water heater supply valve and close the water heater bypass valve. Open the fresh water tank supply valve from the pump and the ice maker valve. Reinstall the water filter. Be sure to close the fresh water tank drain valves to allow the tank to fill.

Notes

CHAPTER 15

CHARTS & DIAGRAMS

Table of Contents

Model Numbers	15 - 1
Maintenance Record	15 - 2
Fuel & Mileage Log	15 - 5
12 Volt Distribution Panel	15 - 7
30 Amp Distribution Panel	15 - 9
50 Amp Distribution Panel	15 - 11
Wiring Color Scheme	15 - 13
Typical 110 Volt Wiring Diagram	15 - 17
Typical 12 Volt Wiring Diagram	15 - 19
TV/VCR Wiring Diagram	15 - 21
Typical Fresh Water Diagram	15 - 23
Typical Drain Line Diagram	15 - 25
Slide Out Mechanism	15 - 29
Brief Parts Listing	15 - 31

IMPORTANT INFORMATION ABOUT YOUR KOUNTRY STAR FIFTH WHEEL

Coach: Year 2000 Model _____ Serial # 7 _____

Appliance	Brand	Model	Serial
Refrigerator	_____	_____	_____
Water Heater	_____	_____	_____
Range	_____	_____	_____
Converter	_____	_____	_____
Washer	_____	_____	_____
Dryer	_____	_____	_____
Microwave	_____	_____	_____
Icemaker	_____	_____	_____
Television, front	_____	_____	_____
Television, rear	_____	_____	_____
Radio	_____	_____	_____
CD Player	_____	_____	_____
Generator	_____	_____	_____
Air Conditioner, front	_____	_____	_____
Air Conditioner, rear	_____	_____	_____
Video Cassette Recorder (VCR)	_____	_____	_____
Furnace, front	_____	_____	_____
Furnace, rear	_____	_____	_____

MAINTENANCE RECORD

DATE	MILES	DESCRIPTION OF SERVICE WORK PERFORMED	SERVICE PERFORMED BY	COST	

MAINTENANCE RECORD

DATE	MILES	DESCRIPTION OF SERVICE WORK PERFORMED	SERVICE PERFORMED BY	COST

MAINTENANCE RECORD

DATE	MILES	DESCRIPTION OF SERVICE WORK PERFORMED	SERVICE PERFORMED BY	COST	

FUEL, OIL & MPG RECORD

DATE	ODOMETER MILEAGE	FUEL GALS.	OIL QTS.	AVE. MPG	COST	

DATE	ODOMETER MILEAGE	FUEL GALS.	OIL QTS.	AVE. MPG	COST	

FUEL, OIL & MPG RECORD

DATE	ODOMETER MILEAGE	FUEL GALS.	OIL QTS.	AVE. MPG	COST

DATE	ODOMETER MILEAGE	FUEL GALS.	OIL QTS.	AVE. MPG	COST



12 VOLT DISTRIBUTION PANEL

HOT FEED LINES FROM BATTERIES
AND CONVERTER, WITH
OVERCURRENT PROTECTION

GROUND TO CHASSIS,
CONVERTER AND BATTERIES
MINIMUM SIZE #8

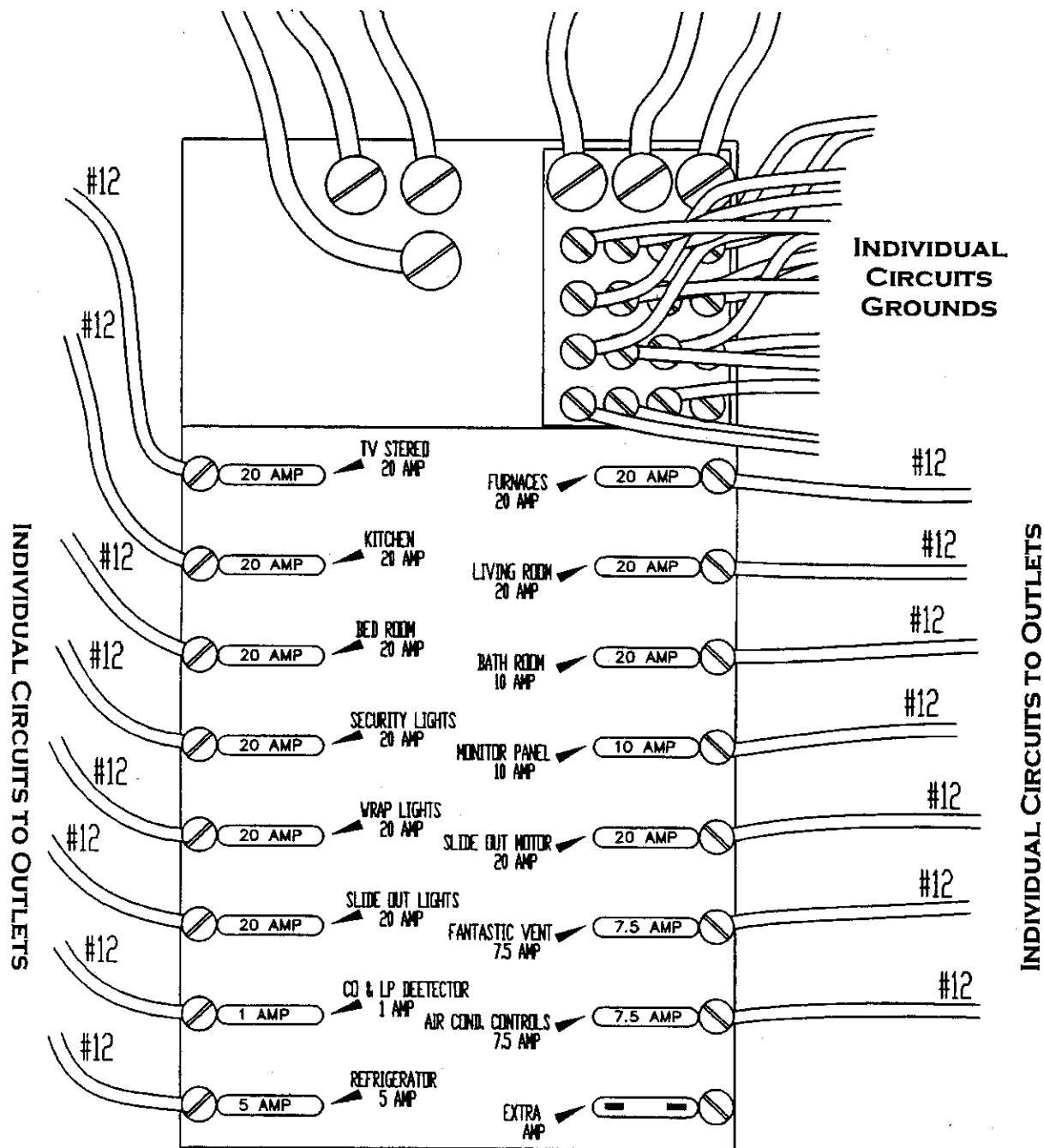

WIRE OVER CURRENT PROTECTION IS PER THIS CHART

WIRE SIZE	AMPACITY	WIRE SIZE	AMPACITY
# 6	55	# 8	40
# 10	30	# 12	20
# 14	15	# 16	8
# 18	6		

30 AMP ELECTRICAL PANEL

load protection

30 AMP MAIN	
AIR CONDITIONER	# 1
	20 AMP
MICROWAVE	# 2
	15 AMP
WATER HEATER	# 3
	15 AMP
REFRIGERATOR	# 4
& 8 RECEPITS	15 AMP
CONVERTER	# 5
& 8 RECEPITS	15 AMP

30 AMP 110 SERVICE

30 Amp lead in cord & wire = 10/2 w/ground
 20 Amp circuit wire = 12/2 w/ground
 15 Amp circuit wire = 14/2 w/ground

Maximum of 10 outlets (lights and receipts) on any 15 amp circuit with no other appliance on that line. Circuits 3 and 4 may have receipts as noted at left. NOTE: A duplex receipt is counted as 1 receipt.

Not all units will get all of these items
 This diagram is a typical only

50 AMP ELECTRICAL PANEL

load	protection	50 AMP MAIN		protection	load
1st	# 1			# 13	MAY HAVE 10 RECEPTS
AIR COND.	20 AMP			15 AMP	
MICROWAVE	# 2			# 14	MAY HAVE 10 RECEPTS
	15 AMP			15 AMP	
2nd	# 3			# 15	MAY HAVE 10 RECEPTS
AIR COND.	15 AMP			15 AMP	
WATER HEATER	# 4			# 16	DISHWASHER
	15 AMP			15 AMP	
REFRIGERATOR	# 5				
FOOD CENTER & 5 RECEPTS	15 AMP				
CONVERTER & 5 RECEPTS	# 6				
	15 AMP				
DRYER	# 7				
	15 AMP				
WASHER	# 8				
	20 AMP				

This is a 50 Amp 220 service

50 Amp lead in cord to box = 6/3 w/ground
 20 Amp circuit wire = 12/2 w/ground
 15 Amp circuit wire = 14/2 w/ground

Maximum of 10 outlets (lights and recepts) on any 15 amp circuit with no other appliance on that line. Circuits 3, 4, and 16 may have recepts as noted at left. NOTE: A duplex recept is counted as 1 recept.

This is a fully loaded system for which there has been a calculation done. Not all units will get all of these items. This diagram is a typical only

WIRING COLOR SCHEME

16 GAUGE

Grounds	White
Back-up Lights	Yellow
Ignition to Power Step	Pink
Clearance & Running Lights	Green
Right Turn Lights	Brown
Left Turn Lights	Red
Ignition to Slide Out Motor	Pink w/Green
Class A Blower Fan (in holding tank area)	Orange
Slide Out Switch	Purple
Courtesy Lights (hot to switch)	Grey
Courtesy Lights (switched)	Grey w/White
Detectors, CO & LP	Red w/Black
Rear Center Brake Light	Blue
LP Fuel Gauge	Red w/Yellow
Air Conditioner Controls	Pink w/Black
Monoplex Water Pump Switch	Yellow w/Black
Vent Thermostats	Black

Water Heater DSI Switch Harness	{	Red w/White*
		Green w/White*
		Blue w/White*
Onan Generator	{	Red w/White*
		Green w/White*
		Blue w/White*
		Brown*
Powertech Generator	{	Blue*
		Gray*
		Yellow*
		White*

* - multiple applications for this color

WIRING COLOR SCHEME (CONT.)

12 GAUGE

Grounds	White
Living Room & Entryway Lights (hot to switch)	Red
Living Room & Entryway Lights (switched)	Red w/White
Bedroom Lights (hot to switch)	Orange
Bedroom Lights (switched)	Orange w/White
Bathroom Lights (hot to switch)	Brown
Bathroom Lights (switched)	Brown w/White
Kitchen Lights (hot to switch)	Green
Kitchen Lights (switched)	Green w/White
Wrap & Storage Compartment Lights	Black
TV and Stereo	Pink
Furnaces	Green w/Black
3 Way Switches (commons)	Red w/Black
Electric Brakes (tandem axle)	Blue
Fantastic Vent and Water Heater	Brown w/Black
Monitor Panel	Yellow
Refrigerator Controls	Purple w/White
Security Lights (hot to switch)	Purple
Security Lights (switched)	Purple w/White
Slide Out Module (hot feed)	Green/Yellow
Slide Out Motor & Voice Module	Black w/Yellow & Red w/Yellow
Slide out Lights	Grey
Water Pump	Yellow w/Black
Power Step Switch	Black w/White

WIRING COLOR SCHEME (CONT.)

10 GAUGE

Grounds	White
Living Room Entry Lights (hot feed)	Red
Bedroom Lights (hot feed)	Orange
Kitchen Lights (hot feed)	Green
Bathroom Lights (hot feed)	Brown
Power Rear Awning & Freezer	Purple w/Yellow
Power Step (hot feed)	Green w/Black
Power Jacks	Yellow
Electric Brakes (tri-axle)	Blue
100 Watt Inverter	Red w/White

8 GAUGE

Grounds	White
Battery	Red
Converter	Black
Solar Prep	Green

16 GAUGE

MONITOR PANEL TANK HARNESS

Fresh Water Tank	{ White* Grey w/Black (replaces Red tank lead) * Black w/Yellow (replaces Blue tank lead) *
Grey Water Tank	{ White* Green w/White (replaces Red tank lead) * Blue w/Black (replaces Blue tank lead) *
Black Water Tank	{ White* Red w/White (replaces Red tank lead) * Blue w/White (replaces Blue tank lead) *

* - multiple applications for this color



TYPICAL 110 VOLT WIRING DIAGRAM

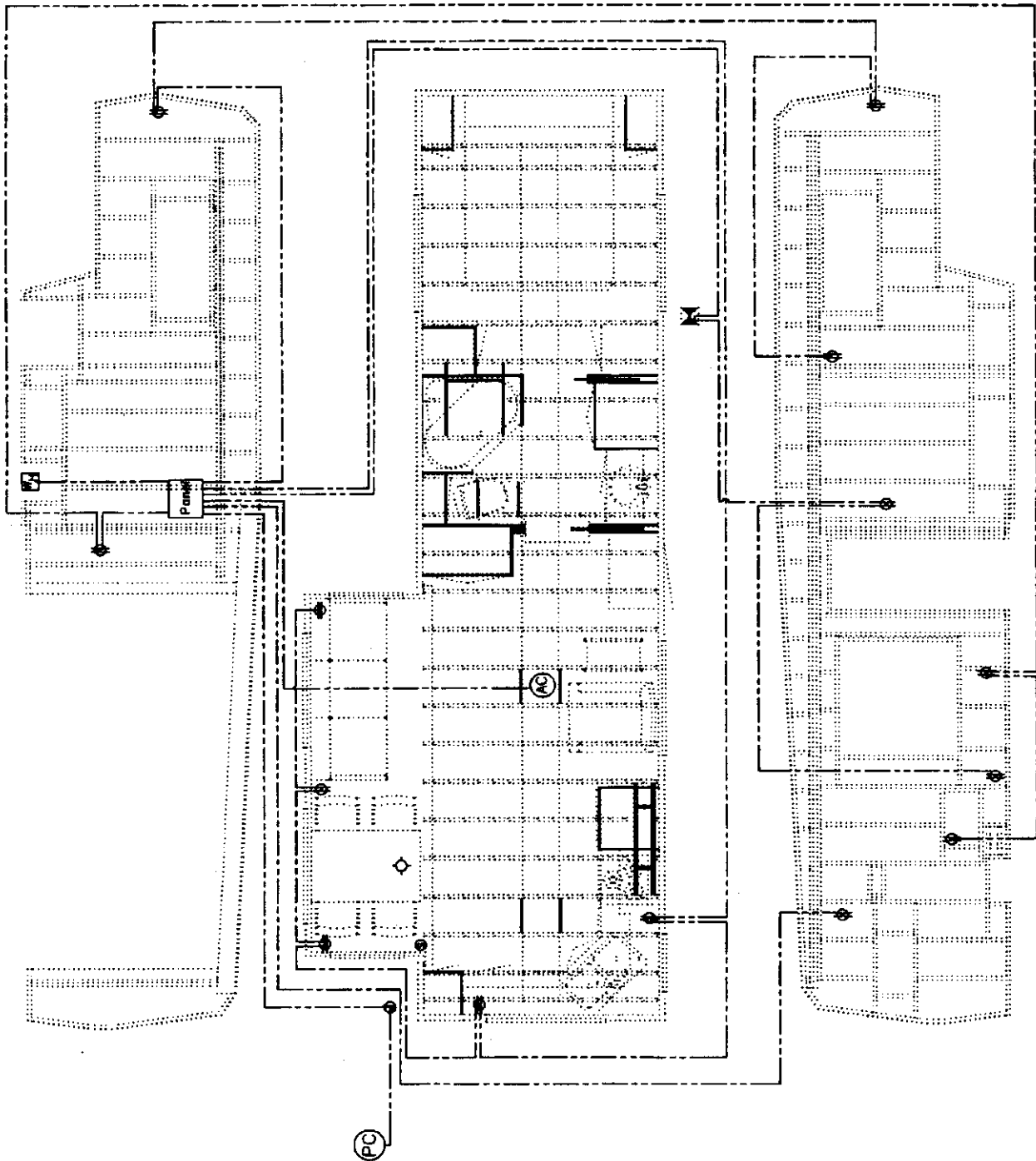

**WIRES ARE ROUTED ACROSS THE ROOF
AND IN THE TOP SIDE WRAP OF THE UNIT.
THE WIRES ARE ROUTED TO KEEP
THE SHORTEST PRACTICAL LENGTH.**

TYPICAL 12 VOLT WIRING DIAGRAM

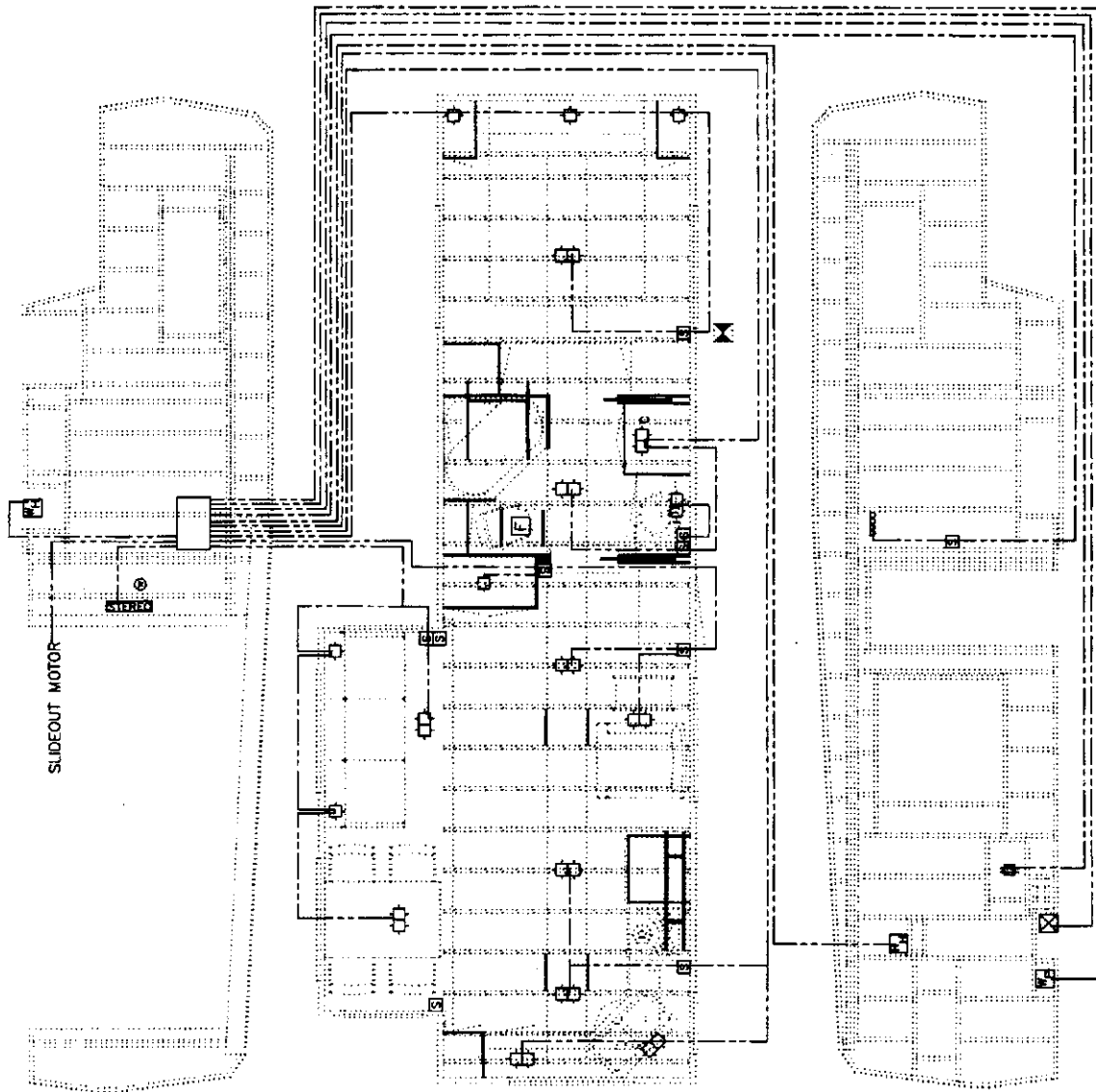

**WIRES ARE ROUTED ACROSS THE ROOF
AND IN THE TOP SIDE WRAP OF THE UNIT.
THE WIRES ARE ROUTED TO KEEP
THE SHORTEST PRACTICAL LENGTH.**

TV / VCR WIRING DIAGRAM

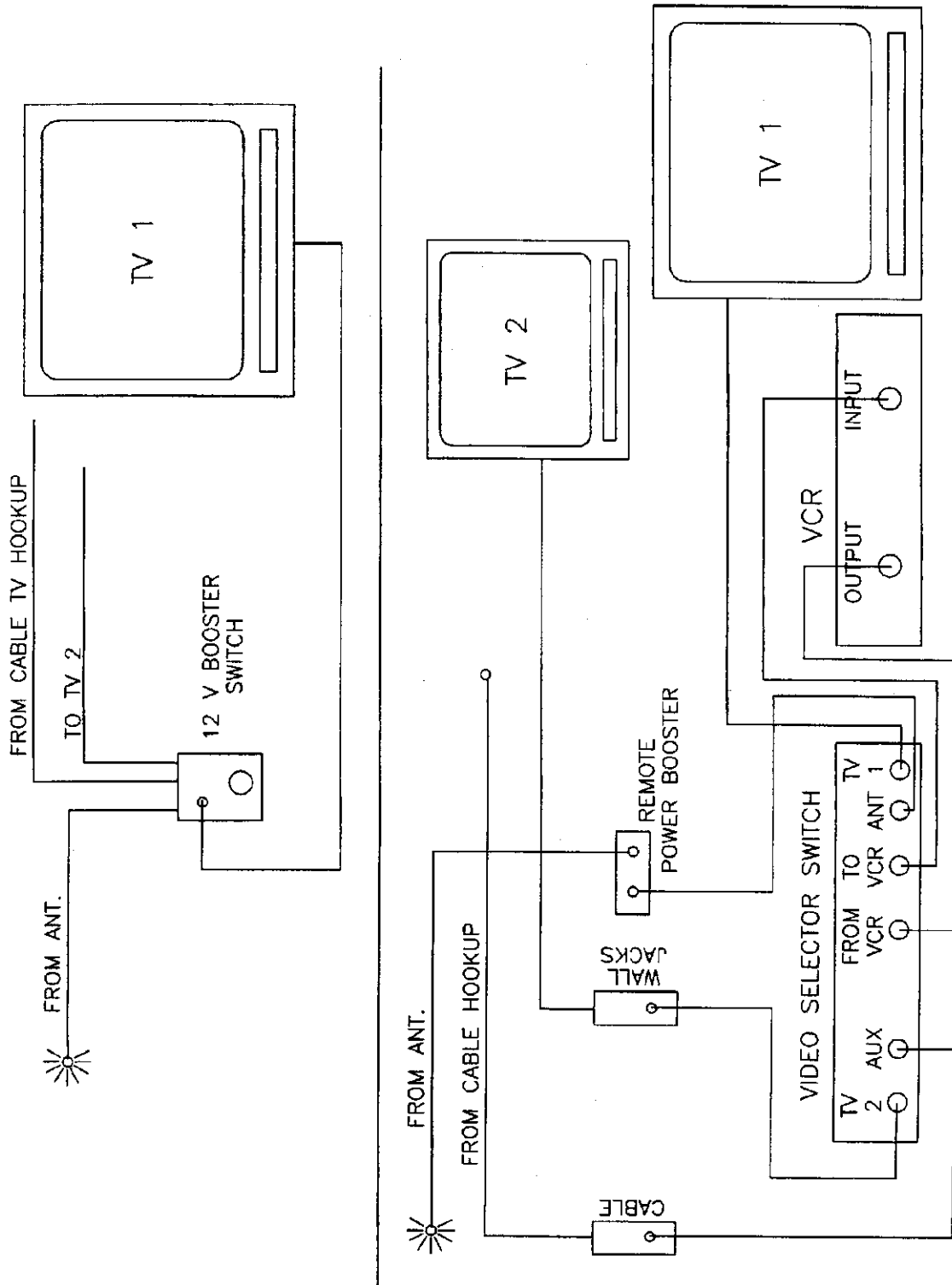

TYPICAL FRESH WATER DIAGRAM

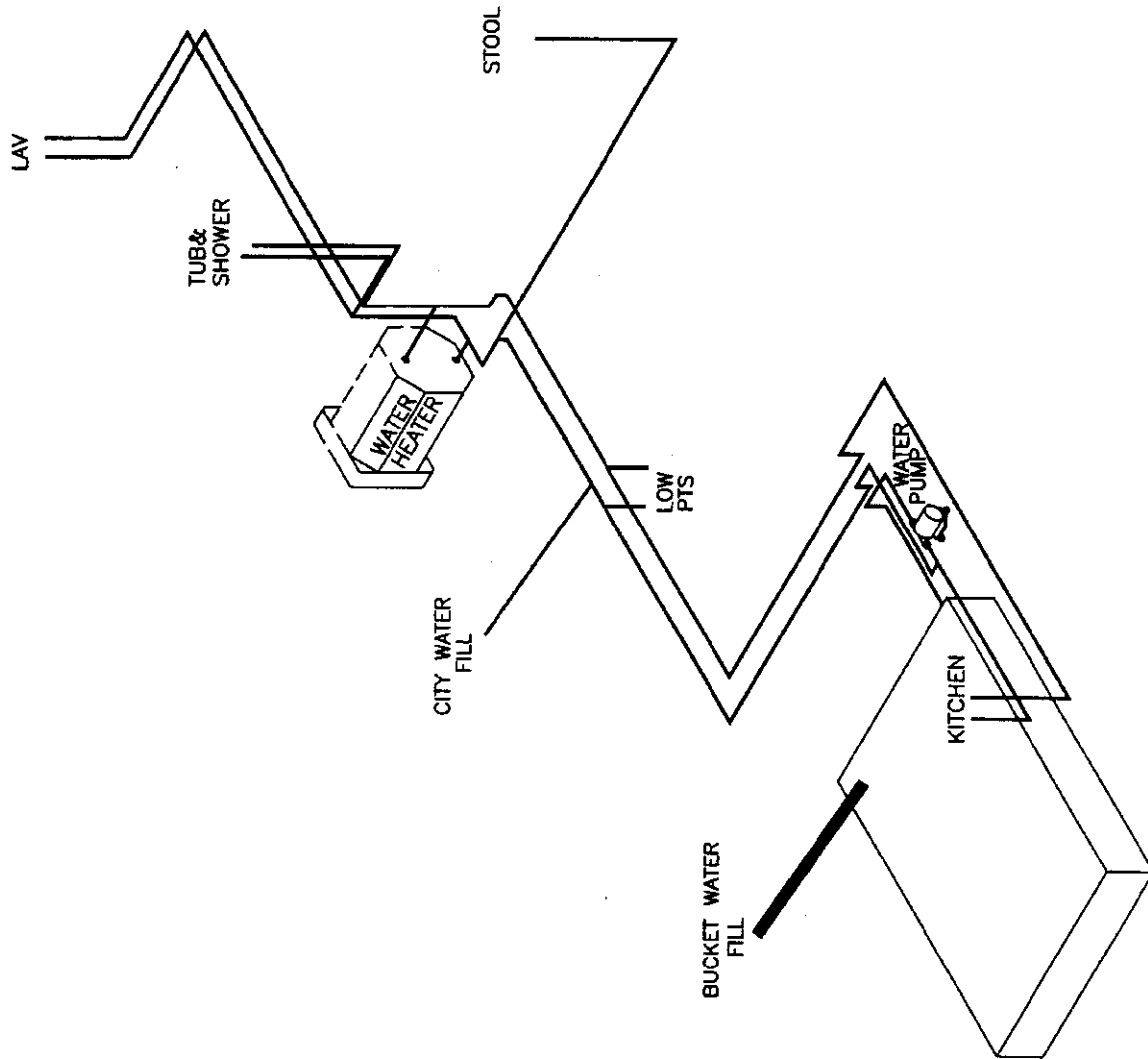

TYPICAL DRAIN LINE DIAGRAM FOR UNITS 34 FEET AND LESS

NOTE:

- All materials used in the drainage system conform to ANSI A119.2 4-7.1
- Drain grade set at 1/8 inch per foot minimum
- Drain lines are supported at a maximum interval of 4 feet
- Trap arm grade set at 1/4 inch per foot minimum (total slope does not exceed pipe diameter)
- Maximum trap arm length is 54"
- All traps are a minimum required size of 1 1/4" except the washer (if applicable) requires 1 1/2"
- All traps are removable for use as a cleanout access

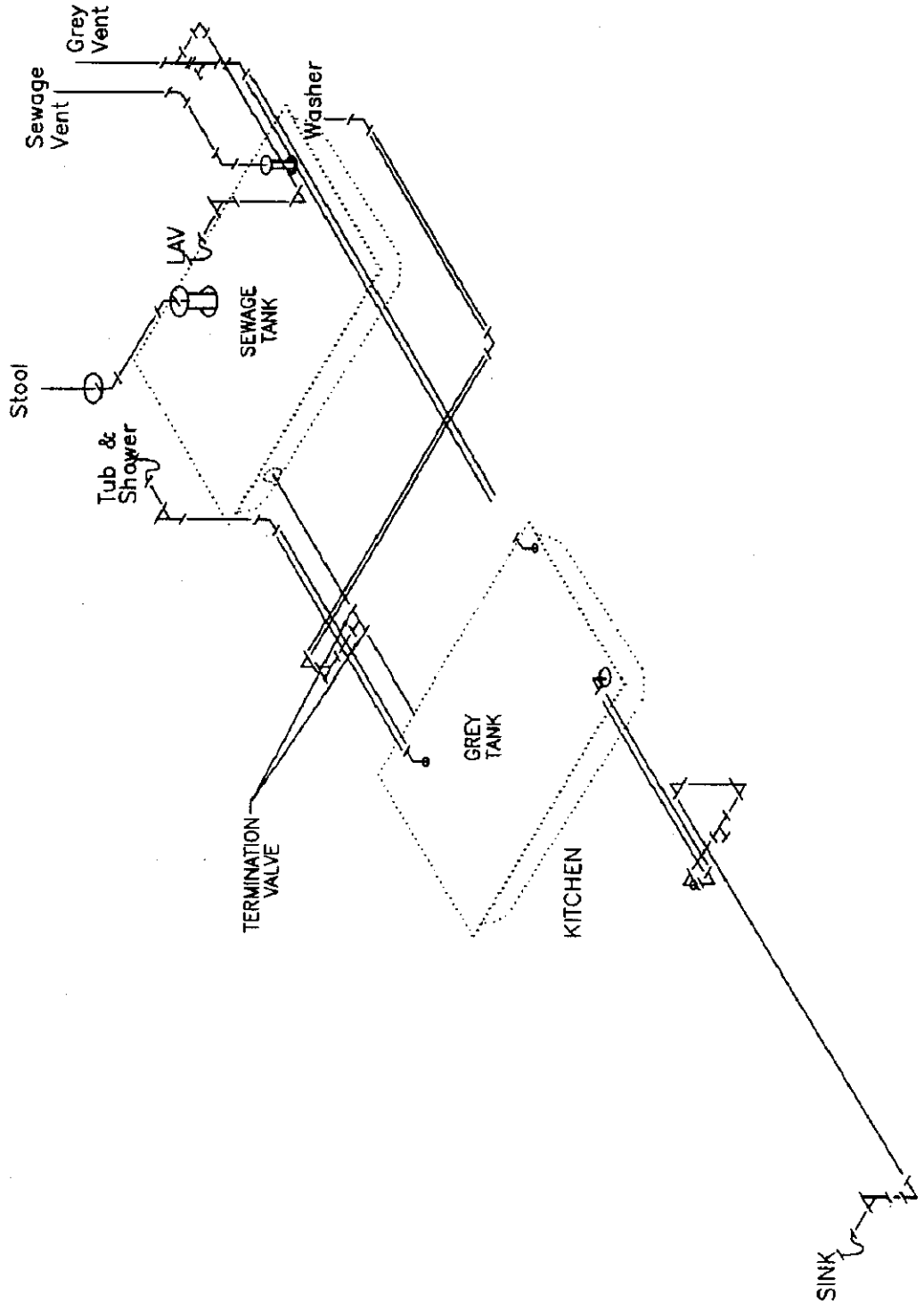

NOTE:
 ALL PIPE & FITTINGS ARE ABS SCHED. #40
 DRAIN GRADE TO BE 1/8" PER FOOT
 SUPPORT PIPE EVERY 4 FT MAX
 ALL TRAP ARMS 54" MAX
 ALL FIXTURES HAVE 1 1/4" P-TRAPS MINIMUM
 ALL TANK HOOK-UPS USE A DOUBLE LTTY UNLESS SPECIFIED OTHERWISE
BELOW FLOOR PLUMBING
 SEE TYPICAL FOR WASHER INSTALLATION
 BATH FLOOR LOCATION -----
 P-TRAPS MAY BE USED AS CLEANOUTS

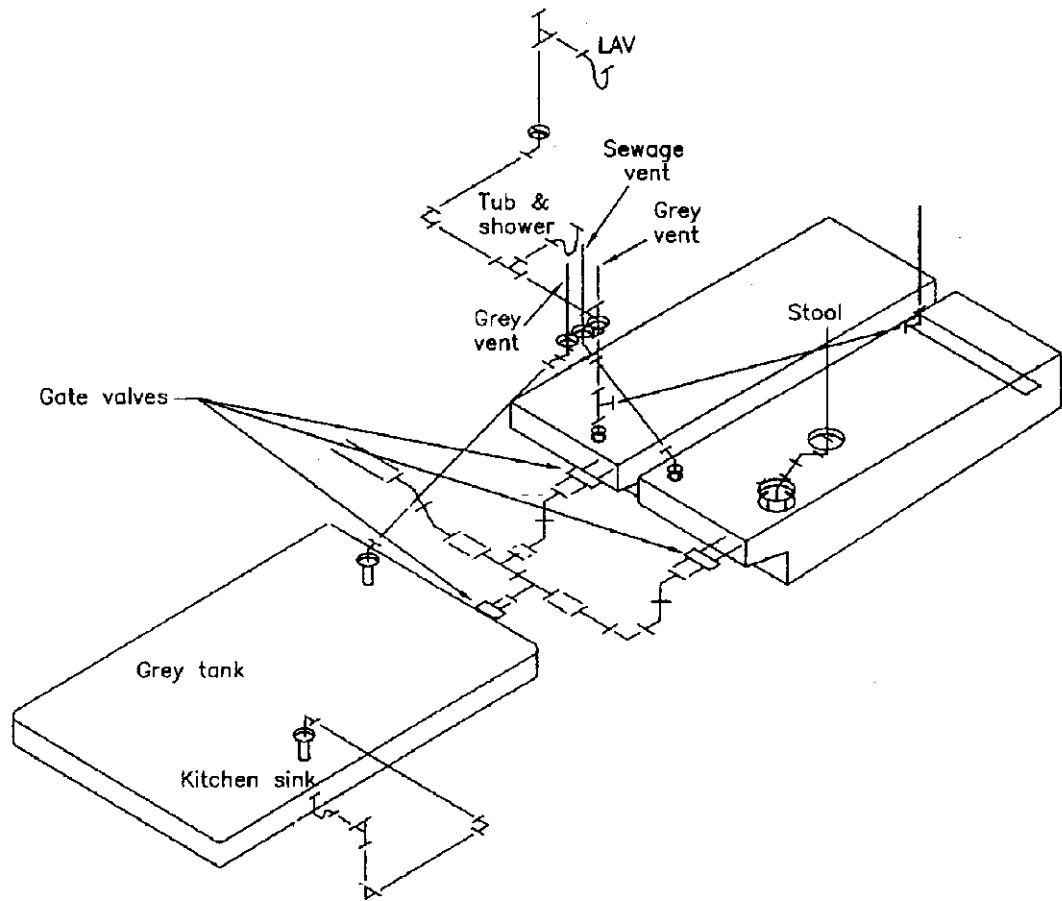

SINGLE MOUNT SLIDE OUT MOTOR INSTALLATION DIAGRAM

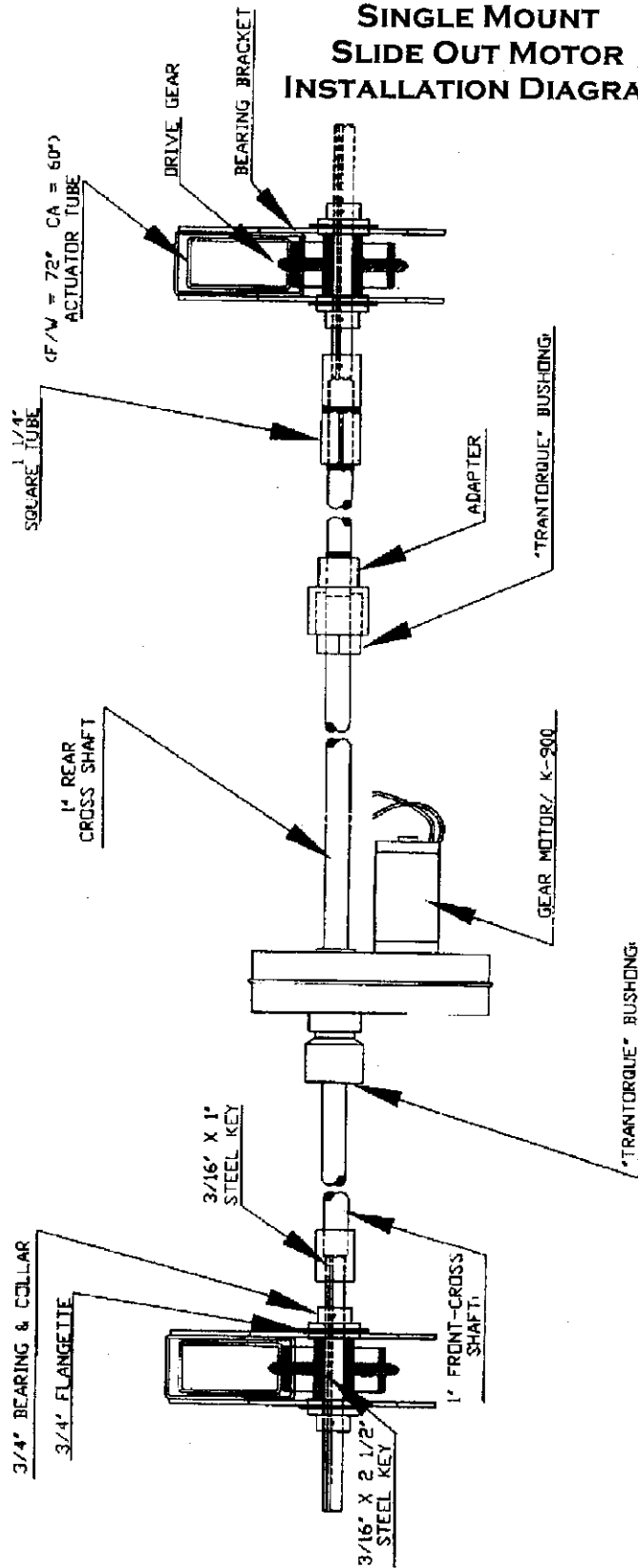

2000 KOUNTRY STAR FIFTH WHEEL

DESCRIPTION	ITEM #
Antenna, TV	QD 34320
'Door, Main Entrance, Fifth Wheel	ID 36572
Door, Furnace	QC 21868
Door, Refer Vent	QF 11526
Faucet, Lav, Std	CM 22540
Faucet, Kitchen, Sgl Hdl	CM 38901
Faucet, Shower, (except 30RKCL)	CM 22541
Ladder, KS FW	NA 24609
Ladder, KS FW, w/Bay Window	NA 31394
Light, Scare	EH 10674
Receipt, 12 Volt, White	EB 10641

DESCRIPTION	ITEM #
Receipt, 120 Volt, White	EB 10551
Receipt, GFCI	EB 10553
Register, Floor	QC 12292
Register, Ceiling	QC 37945
Roof Rack	NA 11820
Sink Cover	NA 35004
Skylight	IS 14607
Switch, 12 Volt, Double, White	EB 24810
Switch, 12 Volt, Single, White	EB 24809
Switch, 12 Volt, Triple, White	EB 24811
Switch, 120 Volt, White	EB 10543
Switch, 120 Volt, Brown	EB 10542
T-Stat, Dometic	QA 27782