

# MOUNTAIN AIRE *2011*

OWNER'S GUIDE



WHEN YOU KNOW THE DIFFERENCE

Welcome to the exciting world of recreational vehicle traveling and the growing Newmar family!

Congratulations on your purchase of a Newmar product. We sincerely thank you for choosing Newmar as your recreational vehicle. We hope that you will enjoy many miles of traveling. Your new vehicle was built with care using today's technology and old world craftsmanship. We, at Newmar, strive to build vehicles that are safe, dependable, and comfortable to provide you with years of carefree, pleasant traveling.

Carefully read both the instructions in this Owner's Guide and the booklets supplied by the chassis and component manufacturers for important operation, safety, and maintenance requirements/information. Your dealer should be consulted should you have any questions. If your dealer is unable to answer the questions to your satisfaction he will refer you to our staff for assistance. Our customers are extremely important to us and we will make every effort necessary to ensure your satisfaction.

The limited warranties issued by the chassis and component manufacturers require periodic service and maintenance. The owner's failure to provide this service and/or maintenance may result in the loss of warranty coverage. Be sure to file the appropriate registration card with the component manufacturer as described with the individual instruction booklets to activate the warranties on the components within your Newmar RV. This Owner's Guide should be kept in your vehicle for quick reference. Take time to get acquainted with your unit and how it operates.

Again, thank you and welcome to the Newmar family.

Newmar Corporation

This guide has been provided by Newmar Corporation solely for the purpose of providing instructions about the operation and maintenance of this vehicle and its components. Nothing in this manual creates any warranty, either expressed or implied. The only warranty offered by Newmar Corporation is set forth in the written limited warranty that applies to this vehicle.

Instructions are included in this manual for operating some of the components that are standard on this vehicle. Instructions are also given for components that are options and may not appear on all vehicles. For more detailed information on components refer to the individual manufacturer's operating instructions contained in the Owner's Information Package.

The limited warranties issued by the chassis and component manufacturers require periodic service and maintenance. The owner's failure to provide this service and/or maintenance may result in the loss of warranty coverage. The owner should review the Newmar Corporation Limited Warranty and other manufacturers' limited warranties on all components applicable to this vehicle. To activate the warranties on the components within your Newmar recreational vehicle, be sure to file the appropriate registration card with the component manufacturer as described with the individual instruction booklet.

Throughout this guide, reference is made to the following terms: Warning, Caution, and Important. These terms indicate important information that must be understood and followed. The definitions of these terms are:

 WARNING

Emphasizes an area in which personal injury or even death could result from failure to follow instructions properly. Mechanical damage may also occur.

 CAUTION

Failure to observe a caution can cause damage to the equipment or unit. Personal injury is unlikely.

 IMPORTANT

This will provide additional information to make a step easier or clearer.

Chapter 1

# SERVICE INFORMATION

CUSTOMER ASSISTANCE.....	3
COMPONENT PART SUPPLIERS .....	3
Accessories .....	3
Air Conditioning .....	4
Appliances .....	4
Electrical .....	4
Exterior .....	4
Heating .....	5
TO OUR VALUED CUSTOMERS: .....	6



## CUSTOMER ASSISTANCE

Newmar Corporation.....	1-800-731-8300
Ford Motor Company.....	1-800-444-3311
Freightliner Custom Chassis.....	1-800-FTL-HELP
Spartan Motors.....	1-800-543-4277
Spartan Roadside Companion.....	1-888-890-1741
Workhorse Custom Chassis .....	1-877-946-7731

## COMPONENT PART SUPPLIERS

### Accessories

Back Up Monitor	Atlanta DTH .....	770-451-9777
	A. S. A. Inc. ....	574-266-1886
	C.T.D.....	800-777-4856
	Total Vision Products .....	520-623-0790
Back Up Monitor (Panasonic)	Mito .....	888-433-6486
CB Radio (Cobra)	Tri Star Distributing .....	800-456-3340
Computer TripTek	River Park, Inc. ....	800-442-7717
Furniture (Upholstered)	Flexsteel Industries.....	563-556-7730
	International .....	714-535-7272
Grill, Electric Tabletop	Meco.....	800-251-7558
Internet System (Trac-Net)	River Park, Inc. ....	800-442-7717
Navigation	Mito .....	888-433-6486
Navigation (DVD)	C.T.D.....	800-777-4856
Roof Vent	FanTastic Vent Corp.....	800-521-0298
	Ventline .....	574-848-4491
Security System	Nagy Fleet Net Inc. ....	574-262-4479
Stereo AM/FM	Odyssey .....	800-877-0521
	River Park, Inc. ....	800-442-7717
Stereo (Audiovox)	A. S. A. Inc. ....	574-266-1886
Stereo (Pioneer)	C.T.D.....	800-777-4856
Stereo (Sony)	River Park, Inc. ....	800-442-7717
TV Antenna	The Winegard Co. ....	800-288-8094
Television (Magnavox)	Midwest Sales .....	574-287-3365
Television (RCA)	Tri Star Distributing .....	800-456-3340
Television (Sony)	River Park, Inc. ....	800-442-7717
Television (Zenith)	Odyssey .....	800-877-0521
Television (LCD Monitor) KADP	A. S. A. Inc. ....	574-266-1886
Satellite Dish	The Winegard Co. ....	800-288-8094
Satellite Dish (Datron)	A. S. A. Inc. ....	574-266-1886
Satellite Dish (KVH)	River Park, Inc. ....	800-442-7717

VCR (RCA)	Collins & Company.....	574-848-1118
VCR (Sony)	River Park, Inc. ....	800-442-7717

### Air Conditioning

Dash Air	Evans Tempcon.....	800-354-7088
Roof Air	Dometic .....	800-544-4881
Basement Air	Suburban Mfg. ....	800-659-2138

### Appliances

Dishwasher, 18" (Frigidaire)	Frank-lin Premiums .....	866-213-9397
Dishwasher, 24"	Midwest Sales .....	574-287-3365
Freezers	Norcold .....	800-543-1219
Ice Makers	U-Line.....	800-779-2547
Microwave (Dometic)	Dometic .....	800-544-4881
Microwave (GE)	Collins & Company.....	574-848-1118
Range	Atwood-Greenbrier .....	815-877-5700
	Magic Chef .....	515-792-7000
Refrigerator	Dometic .....	800-544-4881
	Norcold .....	800-543-1219
Water Heater	Atwood Mobile Prod. ....	815-877-5700
	Suburban Mfg. ....	800-659-2138
	Vehicle Systems .....	800-685-4298
Washer/Dryer, 1-piece	Splendide .....	800-736-4127
Washer/Dryer, 2-piece	Whirlpool.....	800-442-1111

### Electrical (tires and batteries separately warranted)

Batteries - 12Volt	Interstate .....	800-872-4100
Batteries - 6 Volt	Interstate .....	888-772-3600
Converter	IOTA .....	877-682-4682
Generators	Generac.....	800-747-1530
	Onan .....	800-888-6626
	Power Tech .....	800-760-0027
Inverters	Xantrex .....	800-446-6180

### Exterior

Awning & Hardware	A & E.....	800-544-4881
	Carefree of Colorado .....	800-621-2617
	Girard.....	800-382-8442
Axle & Components	Axle .....	574-295-1900
Hitch (CA & DP)	Hidden Hitch.....	877-869-6787
Jacks (CA & DP)	H W H Corporation .....	800-321-3494
Jacks (FW & TT)	Atwood Mobile Prod. ....	815-877-5700

Rubber Suspension	Mor-Ryde, Inc. ....	574-293-1581
Steps, Electrical (KS DP)	Fleming (SCS).....	800-275-7524
Steps, Electrical	Kwikee Products .....	800-736-9961
Steps, Manual	Hickory Springs Mfg. ....	501-646-6161
	Elkhart Tool and Die .....	574-295-8500
Tires	Goodyear .....	800-227-1999
	RFD Components .....	574-295-3939

## Heating

Furnaces	Atwood Mobile Prod. ....	815-877-5700
	Suburban Mfg. ....	800-659-2138
Furnace, Aqua-Hot & Hydro-Hot	Vehicle Systems .....	800-685-4298

Please note that your Newmar Limited Warranty is activated only after Newmar has received a signed Warranty Registration Form from your selling dealer. If it has been more than 60 days since the purchase of your new coach and you have not received your Newmar Owner's Warranty Card, please contact your selling dealer or the Newmar Warranty Department at 800-731-8300.



## TO OUR VALUED CUSTOMERS:

If, for any reason, you have a problem obtaining satisfactory and timely warranty service that may substantially impair the use, value or safety of your Newmar product, please call us on our toll free line at 800-731-8300 so that we may attempt to resolve your concerns.

All of the information contained in this brochure is believed to be accurate at the time of publication. However, it may be necessary to make revisions and Newmar reserves the right to make any such changes without notice or obligation. Please refer to the component information literature provided in the Owner's Information Package for specific warranty details for the components applicable to your recreational vehicle.



NEWMAR CORPORATION  
355 N DELAWARE ST  
PO BOX 30  
NAPPANEE, IN 46550-0030  
*www.newmarcorp.com*

## Chapter 2

# GENERAL & SAFETY INFORMATION

DELIVERY .....	3
Dealer Responsibilities.....	3
Customer Responsibilities.....	3
Recreational Vehicle Limited Warranty .....	4
Warranty Service Deadline .....	4
Owner's Information Package .....	4
Customer Relations .....	4
Reporting Safety Defects .....	4
Information Sheet.....	5
IMPORTANT RV TIRE INFORMATION.....	6
READ AND UNDERSTAND THE FOLLOWING INFORMATION BEFORE TAKING YOUR FIRST TRIP IN YOUR RV!.....	6
SAFETY PRECAUTIONS .....	7
Before Starting Out .....	7
Driving .....	7
Side View Cameras (optional) .....	8
Propane & Fuel.....	8
Propane Gas System General Information.....	9
Propane Regulator.....	10
Propane Distribution Lines .....	10
Precautions & Recommendations .....	10
Fire Safety .....	10
Fire Extinguisher .....	10
Smoke Detector .....	11
Emergency Exit Window .....	11
Weight Information.....	11
Weighing the Unit.....	11
Campsite Parking.....	13
Car Towing Hitch .....	14



## DELIVERY

Throughout the manufacturing process your vehicle has been inspected by our qualified technicians. However, our final inspection at the factory is not to be the last one. The pre-delivery inspection and systems check your dealer performs are the final inspections done to the unit prior to you receiving your new coach. Your dealer is also available to assist you in understanding the limited warranties and completing any necessary forms to activate the warranties for the various appliances and accessories installed in your unit.

### Dealer Responsibilities

1. A pre-delivery inspection and systems check. Thoroughly inspecting the vehicle and the operation of the factory installed components.
2. A customer walk-through. This is done to familiarize the customer with the vehicle, its systems and components, and their operation.
3. Delivery of the Owner's Information Package. This package contains the warranty cards and registrations for the vehicle and factory installed components that carry a separate warranty. The detailed operating and maintenance instructions on these components are also included in this package.
4. Assisting the customer in completing the component registration forms, at the customer's request. To avoid loss of warranty coverage, the dealer should review the limited warranty provisions with the customer stressing the importance of filing warranty cards and registrations to the component's manufacturers within the prescribed time limit.
5. Providing the customer with information regarding warranty and non-warranty work on the vehicle and its separately warranted components whether the customer is in or out of the area.

### Customer Responsibilities

The customer is responsible for regular and proper maintenance of the vehicle. Properly maintaining your vehicle will prevent conditions arising from neglect that are not covered by your Newmar Limited Warranty. The maintenance guidelines in this manual and any other applicable manual should be followed. It is your responsibility and obligation to return the vehicle to an authorized dealer for repairs and service.

To assist you in avoiding problems with your vehicle, we recommend you do the following:

- A. **Read the warranty.** Go over it thoroughly with your dealer.
- B. **Inspect the vehicle.** Do not accept delivery until you have gone through the unit with the dealer. Newmar has provided a check list to be used during retail delivery. Check each item on the list and make sure the dealer does the same. Do not sign this checklist until you have done this.

NOTE: The sales literature versus actual specifics to the vehicle's measurements, weights, or quantities may vary.

- C. **Ask questions** about anything that you do not understand concerning your recreational vehicle.
- D. **When taking delivery**, set an appointment for adjustments. This appointment should be approximately two (2) weeks after you accept delivery.
- E. **Responsible Use.** Your vehicle is designed to be used for recreational or temporary living purposes. It is not designed to be used as a full-time residence or for commercial use. Commercial use means using as a business asset such as a mobile office or using the vehicle for lease/rental purposes.

## Recreational Vehicle Limited Warranty

The Newmar Corporation Limited Warranty was provided to you by your selling dealer prior to purchase. Please refer to this document when inquiring about the Newmar Warranty. To receive an additional copy, please refer to the contact information under “Customer Relations”.

### Warranty Service Deadline

Warranty service required needs to be completed during the term of the warranty. Service work scheduled or performed after the expiration of the Newmar warranty **WILL NOT** be covered.

### Owner’s Information Package

Included in this package are valuable documents about your vehicle and its components and systems. The Newmar Owner’s Guide does not cover every possible detail of the equipment, standard and/or optional, installed on or in your vehicle. Consulting the booklets and Instruction Manuals in this package will help you safely operate, maintain, and troubleshoot these items.

Read all of the information and understand the safety and operating instructions included in the Owner’s Information Package. To assure full warranty coverage, it is essential that all maintenance instructions are followed.

### Customer Relations

If you wish to schedule maintenance work, schedule service work, or order parts you should notify your local authorized Newmar Service Center to set up an appointment. If you are unsure of the location of the closest authorized Service Center, please contact us as follows:

Newmar Corporation  
Warranty Department  
72185 C.R. 3  
P.O. Box 30  
Nappanee, IN 46550-0030

Call us at: 1-800-731-8300

Visit us at [www.newmarcorp.com](http://www.newmarcorp.com)

### Reporting Safety Defects

If you believe that your vehicle has a significant defect which could cause a crash or could cause injury or death, you should inform the National Highway Traffic Safety Administration (NHTSA) and Newmar Corporation.

To contact NHTSA, you may either call the Auto Safety Hotline toll free at 1-888-327-4236 (TTY #1-800-424-9153) or write to: NHTSA, 400 Seventh Street, S.W., Washington, DC 20590. NHTSA also has established a website where you can contact them:

<http://www.safercar.gov>

## Information Sheet

Newmar has enclosed an information sheet for your convenience. This sheet contains important information about your coach. The sheet can be found in the black literature bag provided with your unit. Listed on this sheet is the six digit Newmar Serial Number. This number is needed whenever making an appointment for service or ordering parts through your Newmar Dealer or Service Center. Also listed is the Vehicle Identification Number (VIN).

The VIN is the legal identification of the completed vehicle and is used by the state for vehicle registration. Both of these numbers are also listed on the Customer Care card Newmar issues upon receipt of registration.

Below is a sample of the information sheet.

1. The Newmar Serial Number
2. Year/Brand/Type/Floorplan
3. Vehicle Identification Number (VIN)
4. Manufacturer, Model and Serial Number of factory installed equipment.

THANK YOU FOR PURCHASING A QUALITY NEWMAR PRODUCT! FOR YOUR CONVIENCE, WE HAVE ENCLOSED A SERIAL NUMBER LIST OF IMPORTANT EQUIPMENT INSTALLED IN YOUR 2005XXXX###. THE SERIAL NUMBER FOR YOUR UNIT IS #####.

VIN# XXXXXXXXXXXXXXXX DECOR# XX5-### WOODCOLOR CHERRY

CLIMATE SYSTEM		SERIAL #	ENERGY MANAGEMENT SYSTEM		AWNING			
FRONT A/C	630615.321	33087	INVERTER	RV2012M	0062072	AWNING	815DP21	96054
CENTER A/C	630615.321	33088	CONVERTER			AWNING HDW	8551001	561
REAR A/C			GENERATOR	042702	28570	DOOR	4036888B	356
DASH A/C	RV200875	0634	AUDIO/VIDEO/NAVIGATION			WINDOW 1		
FRONT FURN	SF42	05950				FRONT TV	24FV300	60575
REAR FURN			REAR TV	20FS100	72234	WINDOW 3		
AUX HEATER			TV #3			WINDOW 4		
APPLIANCES			EXT TV	4361270		WINDOW 5		
			FRONT	38F180		WINDOW 6		
W						NO TOPPER		

# IMPORTANT RV TIRE INFORMATION

**READ AND UNDERSTAND THE FOLLOWING INFORMATION BEFORE TAKING YOUR FIRST TRIP IN YOUR RV!**



**WARNING**

Routine maintenance on your RV is important, but it cannot be overstated just how critical proper tire maintenance is to the safety, operation, and durability of your new unit. To insure your tires are operating safely, regular inspection of your tires, and checking of tire pressures is absolutely mandatory. **FAILURE TO FOLLOW PROPER INFLATION GUIDELINES MAY RESULT IN TIRE FAILURE, WHICH, UNDER CERTAIN CIRCUMSTANCE CAN CAUSE LOSS OF VEHICLE CONTROL OR ACCIDENTS THAT MAY RESULT IN PROPERTY DAMAGE, BODILY INJURY, AND/OR DEATH.**

For safe operation and maximum weight carrying capacity, it is imperative that the tires be inflated to and maintained at the listed tire pressures on the Federal ID Tag that is affixed to the interior wall just behind the driver's seat in motorhomes, and to the lower front corner of the road side sidewall on fifth wheel trailers. Below is a sample of the Federal ID Tag you will find with your RV.

**IT IS PARAMOUNT TO THE SAFE OPERATION OF THE VEHICLE TO MAINTAIN PROPER TIRE PRESSURES. TIRE PRESSURES SHOULD BE CHECKED AND ADJUSTED BEFORE AND AFTER EACH TRIP, AND SHOULD ALWAYS BE CHECKED AND ADJUSTED WITH THE TIRES COLD. NEVER ADD OR RELEASE PRESSURE FROM THE TIRES WHEN THEY ARE HOT (AFTER HAVING DRIVEN A MILE OR MORE).**

For additional information on your tires, contact the Newmar Corporation.

MANUFACTURED BY / FABRIQUE PAR:		DATE:			
GVWR/PNBV		KG ( LB)			
	GAWR/PNBE		TIRES/PNEU	RIMS/JANTE	COLD INFL. PRESS./PRESS. DE GONFL. A FROID
FRONT/ AVANT	KG ( LB)				KPA SINGLE DUAL PSI(LPC) <input type="checkbox"/> <input type="checkbox"/>
INTERM/ INTERM	KG ( LB)				KPA SINGLE DUAL PSI(LPC) <input type="checkbox"/> <input type="checkbox"/>
REAR/ ARRIERE	KG ( LB)				KPA SINGLE DUAL PSI(LPC) <input type="checkbox"/> <input type="checkbox"/>
<p>THIS VEHICLE CONFORMS TO ALL APPLICABLE U.S. FEDERAL MOTOR VEHICLE SAFETY STANDARDS IN EFFECT ON THE DATE OF MANUFACTURE SHOWN ABOVE.                  THIS VEHICLE CONFORMS TO ALL APPLICABLE STANDARDS PRESCRIBED UNDER THE CANADIAN MOTOR VEHICLE SAFETY REGULATIONS IN EFFECT ON THE DATE OF MANUFACTURE. - CE VEHICULE EST CONFORME A TOUTES LES NORMES QUI LUI SONT APPLICABLES EN VERTU DU REGLEMENT SUR LA SECURITE DES VEHICULES AUTOMOBILES DU CANADA EN VIGUEUR A LA DATE DE SA FABRICATION.</p>					
V.I.N./N.I.V.:		TYPE/TYPE:		FD-228	

## SAFETY PRECAUTIONS

### WARNING

Prior to driving your vehicle, be sure you have read this entire Owner's Guide and that you understand your vehicle's equipment completely and how to use the equipment safely. Read and understand all of the instructions and precautions in this Owner's Guide and the chassis manufacturer Owner's Manual before operating your new motorhome. Listed below are some safety precautions that must be adhered to while your motorhome is in motion. These precautions, as well as others that involve possible damage to equipment, are also listed in the appropriate areas in this manual.

 **DANGER ANY MOTORIZED VEHICLE OR ANY MOTORIZED EQUIPMENT POWERED WITH FLAMMABLE LIQUID CAN CAUSE FIRE, EXPLOSION, OR ASPHYXIATION IF STORED OR TRANSPORTED WITHIN THE RECREATIONAL VEHICLE. TO REDUCE THE RISK OF FIRE, EXPLOSION, OR ASPHYXIATION:**

- (1) Do not ride in the vehicle storage area while the vehicles are present.
  - (2) Do not sleep in the vehicle storage area while vehicles are present.
  - (3) Close doors and windows in walls of separation (if installed) while any vehicle is present.
  - (4) Run fuel out of engines of stored vehicles after shutting off fuel at the tank.
  - (5) Do not store, transport, or dispense fuel inside this vehicle.
  - (6) Open the windows, openings, or air ventilation systems provided for venting the transportation area when vehicles are present.
  - (7) Do not operate gas appliances, pilot lights, or electrical equipment when vehicles are present.
- FAILURE TO COMPLY COULD RESULT IN AN INCREASED RISK OF FIRE, EXPLOSION, ASPHYXIATION, DEATH, OR SERIOUS INJURY.

### Before Starting Out

The following is a brief list of procedures that will aid in your driving safety and extend your equipment's life.

Windows, mirrors, and light lenses are to be clean and unobstructed.

Tires should be checked for proper cold inflation pressure.

Wheel lug nuts should be checked for proper tightness.

Fluid levels, including engine oil, transmission fluid, coolant, power steering fluid, brake fluid, and windshield washer solvent, should be checked and filled if necessary.

Disconnect the unit and store the sewer and water supply hoses as well as shoreline power cords.

Secure all cargo in the storage compartments in the event of a sudden stop.

Verify that the step has retracted prior to engine ignition.

### Driving

There are various adjustments that need to be made prior to starting and moving the vehicle.

Among them are the driver's seat, the tilt steering, and the exterior rear view mirrors.

The dashboard may contain several gauges and controls you have not previously used. Become familiar with all of these devices and their operation before starting out.

The cruise control is not to be operated on icy roads, extremely wet roads, winding roads, heavy traffic, or in any other traffic situation where a constant speed cannot be maintained.



While driving on slippery surfaces, use care when accelerating or decelerating. Skidding and loss of vehicle control may be the result of abrupt changes in speed.

Driving through water deep enough to wet the brakes may affect the stopping distance or cause the vehicle to pull to one side. If you have driven through deep water, check the brake operation in a safe area to be sure they have not been affected. Never operate a vehicle if a difference in braking efficiency is noticeable.

Extreme terrain and adverse weather may affect the handling and/or performance of your vehicle. Please refer to your chassis Manual for related information.

### Side View Cameras (optional)

As an option for the rear vision system, your unit may be equipped with “side view” cameras. These cameras are tied into the rear vision system and are activated by the turn signals. When a turn signal is activated, the monitor will switch to display that side of the unit. If the rear vision monitor is turned on manually, you can toggle through the cameras by using the “source” button, allowing you to stay on any given camera that you chose.

### Propane & Fuel



#### WARNING

Propane cylinders shall not be placed or stored inside the vehicle. Propane cylinders are equipped with safety devices that relieve excessive pressure by discharging propane to the atmosphere. FAILURE TO COMPLY COULD RESULT IN DEATH OR SERIOUS INJURY.



#### WARNING

IT IS NOT SAFE TO USE COOKING APPLIANCES FOR COMFORT HEATING. Cooking appliances need fresh air for safe operation.

Before operation:

- (1) Open overhead vent or turn on exhaust fan
- (2) Open window

FAILURE TO COMPLY COULD RESULT IN DEATH OR SERIOUS INJURY.

Unlike homes, the amount of oxygen supply is limited due to the size of the recreation vehicle, and proper ventilation when using the cooking appliance(s) avoids dangers of asphyxiation. It is especially important that cooking appliances not be used for comfort heating, as the danger of asphyxiation is greater when the appliance is used for long periods of time.



#### WARNING

DO NOT FILL PROPANE CONTAINER(S) TO MORE THAN 80 PERCENT OF CAPACITY. Overfilling the propane container can result in uncontrolled propane flow, which can cause fire or explosion. A properly filled container contains approximately 80 percent of its volume as liquid propane. FAILURE TO COMPLY COULD RESULT IN DEATH OR SERIOUS INJURY.



#### WARNING

Portable fuel-burning equipment, including wood and charcoal grills and stoves, shall not be used inside the recreational vehicle. The use of this equipment inside the recreational vehicle can cause fire or asphyxiation. FAILURE TO COMPLY COULD RESULT IN DEATH OR SERIOUS INJURY.

 **WARNING**

DO NOT BRING OR STORE PROPANE CYLINDERS, GASOLINE, OR OTHER FLAMMABLE LIQUIDS INSIDE THE VEHICLE. FAILURE TO COMPLY COULD RESULT IN FIRE OR EXPLOSION

 **DANGER**

IF YOU SMELL PROPANE:

- (1) Extinguish any open flames, pilot lights, and all smoking materials
- (2) Do not touch electrical switches
- (3) Shut off the propane supply at the container valve(s) or propane supply connection
- (4) Open doors and other ventilating openings
- (5) Leave the area until odor clears
- (6) Have the propane system checked and leakage source corrected before using again

FAILURE TO COMPLY COULD RESULT IN EXPLOSION RESULTING IN DEATH OR SERIOUS INJURY.

 **CAUTION**

Propane regulators must always be installed with the regulator vent facing forward. Regulators that are not in compartments have been equipped with a protective cover. Make sure that the regulator vent faces downward and that the cover is kept in place to minimize vent blockage that could result in excessive propane pressure causing fire or explosion.

## Propane Gas System General Information

A warning label has been placed near the propane gas container. This label reads:

The propane gas system components in your unit have been approved for use in camping vehicles by a nationally recognized testing laboratory. Propane gas is a clean-burning dependable fuel when properly handled. The propane gas tank mounted on your unit contains liquid propane gas under high pressure. The liquid gas vaporizes as the fuel is used and passes through the tank valve to a regulator that automatically reduces the pressure. The low-pressure gas is then distributed to the appliances through the pipe manifold system. Appliance lighting problems are commonly caused by an improperly adjusted gas regulator. Never attempt to reset the regulator yourself. Have an authorized service technician make any necessary adjustments. We recommend that you have the propane gas system checked by an authorized service technician at least once a year and after every extended trip. Although the manufacturer and dealer carefully test for leakage, travel vibrations could loosen fittings. Leaks can be easily found by applying leak detector solution at the connections. If leak detector solution is not available, a soapy water solution made with dish soap can be used. Tightening the fitting usually stops any leaks. If this does not work, shut off the main gas valve at the tank and immediately consult an authorized service technician for repairs. If a leak is suspected, the identifying odor smells similar to rotten eggs (sulfur). Never test for a leak by lighting a match or having an open flame where you suspect leaking gas.

 **WARNING**

Shut off the main gas valve at the tank when the camping vehicle is not in use. Also, shut off the valve when refueling to avoid potential danger from pilot lights igniting fuel fumes. Some appliances, such as the refrigerator, water heater, and furnace, have DSI (direct spark ignition) boards, so it is important that you turn the appliances off when the PROPANE gas is off. The ignition in the appliances will continue to spark even if there is no PROPANE gas available.

## Propane Regulator

The regulator acts as the heart for the propane gas system. The propane gas in the tank is under high pressure. The regulator reduces the pressure of this gas so that it is safe to use with the various appliances in your unit. If corrosion is noticed, contact a qualified propane gas service technician. Do not adjust the regulator. It is factory preset. Adjustments are to be made by a qualified propane service technician using specialized equipment.

Propane gas regulators must always be installed with the diaphragm vent facing downward. Regulators that are not in compartments have been equipped with a protective cover. Make sure that the regulator vent faces downward and that the cover is kept in place to minimize the vent blockage that could result in excessive gas pressure causing fire or explosion.

## Propane Distribution Lines

The primary manifold is a black steel pipe running the length of your unit. Most secondary lines leading to gas appliances are made of copper tubing with flare fittings. If any of the gas lines rupture, do not attempt to splice them. Always run a new line. We recommend gas distribution work be performed by an authorized service technician. The main valve at the propane tank must be closed when removing or servicing any gas appliance. This will prevent dangerous gas leakage that could result in an explosion and possibly serious injury. If a leak is suspected, have the systems inspected and repaired by a qualified service technician.

## Precautions & Recommendations

Inspect the propane fill valve for foreign materials before refueling.

Shut the pilot lights off prior to refueling propane gas tanks.

Never check for gas leaks with an open flame (match, etc.).

Gas lines should be visually inspected periodically.

Have the gas system inspected yearly and before and after extended trips.

The gas system should be inspected and repaired by qualified technicians only.



### WARNING

The propane system in your recreational vehicle is designed for liquefied petroleum gas only. Never attempt to connect natural gas or butane gas in this system.

## Fire Safety

The possibility of fire exists in all areas of life, and the recreational life-style is no exception. Recreational vehicles are complex machines. They are made up of many materials, some of which are flammable. Like most hazards, the possibility of fire can be minimized, if not totally eliminated. This is done by recognizing the danger and practicing common sense safety and maintenance habits. For safety reasons, your unit is furnished with both a fire extinguisher and a smoke alarm.

## Fire Extinguisher

The fire extinguisher is rated for Class B (grease, gasoline, diesel fuel, flammable liquids) and Class C (electrical) fires. These are the most common types of fires in vehicles. Read the Operator's Manual and the instructions on the fire extinguisher. Be sure to know how and when to use the extinguisher and where it is located.

Fire extinguishers are mechanical, pressurized devices. Care must be exercised when they are handled. They must be maintained as the Operator's Manual instructs for proper and safe operation. The extinguisher should be inspected at least once a month. More frequent inspections may be required if the extinguisher is exposed to the weather or to possible tampering. Do not test the extinguisher by partially discharging. Doing this will cause a loss of pressure.

If a fire occurs in the vehicle, evacuate the vehicle as quickly and as safely as possible. Consider the cause and the severity of the fire and the risk involved before trying to extinguish it. If the fire is major or fuel fed, move away from and stand clear of the vehicle and wait for emergency assistance to arrive.

## Smoke Detector

The battery powered smoke detector is mounted on the ceiling in the living area of the unit. Read the operating instructions for details on the testing and care for this important safety device. Test the smoke detector after the unit has been in storage, before each trip, and at least once a week during use.

The detector should never be disabled because of nuisance or false alarm from cooking smoke or a dusty furnace. Ventilate the unit with fresh air and the alarm will shut off. Never disconnect or remove the battery from the smoke alarm. The battery should be replaced once a year or when the low battery signal sounds.

## Emergency Exit Window

In the bedroom of the unit, there is an emergency exit (egress) window. This window is designed to be used as an additional exit in emergency situations. It can be easily identified by the red color of the handle and the red "EXIT" label. To open the egress window, lift the handle and push outward on the window. The window can be closed by pulling the window closed and lowering the handle to the down or locked position.

## Weight Information

Below is a sample of a weight information label which may appear in your unit.

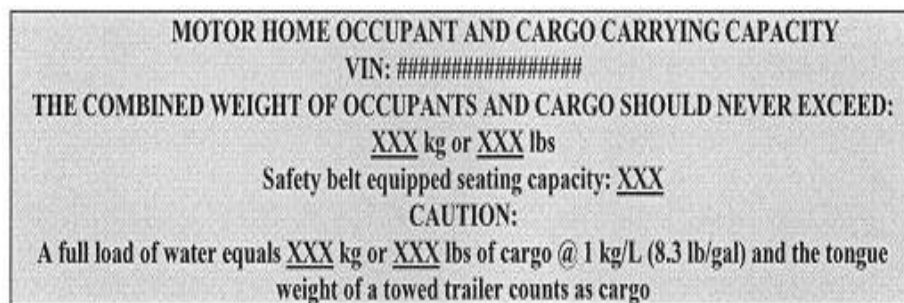

## Weighing the Unit

The following definitions are given to help in communications of issues of weight and your unit.

**GAWR:** Gross Axle Weight Rating is the maximum permissible weight for an axle.

**GCWR:** Gross Combination Weight Rating is the value specified by the manufacturer of the vehicle as the maximum allowable loaded weight of this motorhome and any towed trailer or towed vehicle.

**GVWR:** Gross Vehicle Weight Rating is the maximum permissible weight of this fully loaded motorhome. The GVWR is equal to or greater than the sum of the Unloaded Vehicle Weight plus the Cargo Carrying Capacity.

**UVW:** Unloaded Vehicle Weight is the weight of this motorhome as built at the factory with full fuel, engine oil, and coolants. The UVW does not include cargo, fresh water, propane gas, or dealer installed accessories.

CCC: Cargo Carrying Capacity is equal to GVWR minus each of the following: UVW, full fresh (potable) water weight (including water heater), full propane-gas weight and SCWR.

GVW: Gross Vehicle Weight is the weight of the unit with all items and supplies that are loaded into the unit at any point in time.

SCWR: Sleeping Capacity Weight Rating is the manufacturer's designated number of sleeping positions multiplied by 154 pounds (70 kilograms).

NOTE: The sales literature may give approximates or standards. Each individual unit may weigh differently based on the factory and/or dealer options added. To assure the accuracy of your weights be sure the unit is always level during weighing. The unit has been built to comply with the component suppliers recommended limits and give you a realistic CCC. When loading the unit, distribute the items so that not all of the weight is added to one area of the unit.

If you have questions as to what the weight of the unit is after it has been loaded, take the unit to a drive-on scale or use individual wheel scales and verify that the weights are within the limits of those specified for the unit. When weighing the unit, follow these instructions. Failure to follow these instructions may give an erroneous weight reading.

1. Pull the unit onto the scales shown in Fig. 1. This is the total weight of the unit. To do this, pull the unit onto the scales so that all of the wheels are on the scale. Record the weight. This is the GVW and should not exceed the GVWR supplied by Newmar for the unit.
2. Move the unit so that the front wheels are off the scales as shown in Fig. 2. Record the weight. This is the total weight of the unit except for the front axle. This weight should not exceed the total rating of the axles remaining on the scales. The front axle weight is determined by subtracting this weight from the GVW that was obtained in Step One (1). This amount should not exceed the listed front axle weight rating.

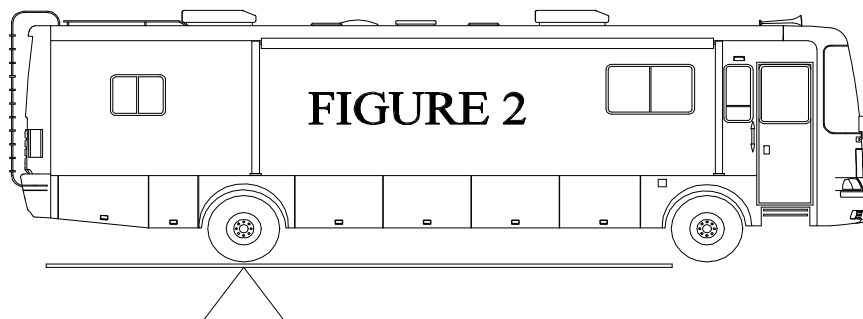
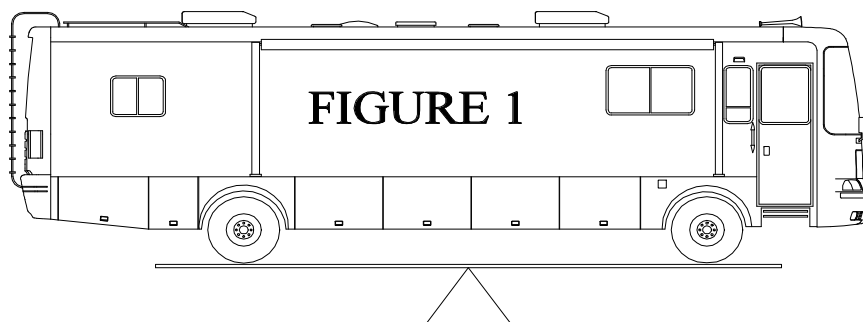

The recommended procedure to weigh a motorhome accurately is on individual corner scales. Since these are not always available, below is a diagram of how to weigh a motorhome on a typical truck scale.

Note: Since only one corner can be weighed at a time, the remaining three corners need to be as close to the scale as possible without being on the scale and the unit needs to be as level as possible. Remember, wind and rain can cause inaccuracies of weights.

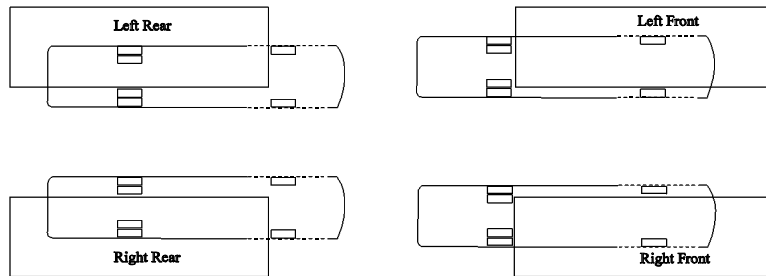

## IMPORTANT

Your RV has been aligned at the factory as part of the production process. To provide optimum tire longevity and offer the best handling characteristics, Newmar recommends you have your unit re-aligned **after** loading your belongings as you would travel. Though highly recommended, this alignment is not mandatory, and as such is not warrantable by Newmar or the chassis manufacturer.

## Campsite Parking

If the campground does not have drive-through sites, it is recommended to stop near the site and inspect it for slopes or uneven areas. Carefully back into the campsite. Watch for low-hanging limbs, posts, large rocks, or other obstacles. Back the unit in so the site is on the driver's left, if possible. This will enable the driver to watch the rear of the unit. Back up slowly using the side mirrors as a guide or with the assistance of another person outside guiding the parking procedure.

Place the vehicle in park and turn off the ignition. If parked on a steep incline, pre-level the coach by driving the appropriate wheels onto blocks. Finish the leveling process by using the leveling jack system to level and stabilize the unit. Connect the 120 volt shore power to the unit. Open the propane gas valves at the propane tanks. Connect the fresh water supply and sanitize the water systems, if necessary. Connect the waste drain hose to the sewer hook-up. Start the refrigerator, water heater, and furnace, if needed. Light the oven pilot light, if applicable. Remember that the refrigerator will not operate efficiently if the unit is not level.



## CAUTION

Do not lift the wheels of the unit off the ground at any time during this process. The unit can roll forward or backward when the weight of the unit is on the jacks.

## Car Towing Hitch

The motorhome is equipped with a towing hitch and wire connector. Two extra 14 gauge wires are also included for your use. Your unit is designed for use as a recreational vehicle and is intended for towing light loads. The instructions for towing are listed in the chassis manufacturer Owner's Manual provided with your unit. The total weight of the motorhome and any vehicle towed by it must not exceed the GCWR. When weighing the motorhome, be sure to take passenger locations into consideration. The towed vehicles must have adequate active brakes. All towed vehicles of 1,500 pounds or more must have independently active brakes.

Please contact your state Department of Transportation or your local Newmar dealer for your state requirements. The wire connector installed is the standard seven-pin connector. Chapter 4 of this guide will have more information regarding this connector.

# Chapter 3

## HVAC, APPLIANCES & ACCESSORIES

HEATING & AIR CONDITIONING.....	3
Air Conditioners.....	3
Ceiling Air Conditioning Ductwork.....	3
Heating (TwinTemp).....	3
Heating (Oasis).....	5
Propane Tank.....	6
Propane Tank Filling.....	6
Propane Regulator.....	6
Propane Leak Detector.....	7
MAJOR APPLIANCES.....	7
Refrigerator.....	7
Microwave.....	8
Range Hood.....	8
Range.....	8
Television Antenna.....	9
Television.....	10
Stereo.....	10
Exterior Entertainment Center (optional).....	10
CB Radio & Antenna (Optional).....	11
Rear View Monitor System.....	11
Air Horns.....	11
Freezer (Optional).....	11
Icemaker (Optional).....	11
Washer/Dryer (Optional).....	11
Carbon Monoxide Detector.....	12





# HEATING & AIR CONDITIONING

## Air Conditioners

The air conditioners installed on your coach will operate only when the unit is supplied with 120 volt AC power from the power cord or the generator. The air conditioners circuit breaker must be in the ON position to work.

To assist the air conditioners in cooling the coach, park in the shade and keep the drapes or blinds closed. Set the thermostat to the desired temperature.

Air conditioners can use a large portion of the available electric power. RV parks may experience low voltage on days with high heat or humidity. This is commonly referred to as a “brown out.” A “brown out” may trip the air conditioners circuit breaker. The circuit breaker protects your air conditioner from damage and is necessary during low voltage conditions. The tripped breaker is not a fault in your electrical system.

The cool air from the air conditioners is ducted throughout the coach through ceiling air ducts. Below is the thermostat that controls the air conditioners. It also controls the furnace. Simply select the desired temperature. The blower will cycle automatically, or you may choose low, medium, or high fan settings.

Remember, both air conditioners must be in the same mode. Please consult the air conditioners manufacturer’s Owner’s Manual for further assistance.



Step One: Move power switch to ON.

Step Two: Press MODE to select function. (Cool\*, furnace, etc.)

Step Three: Press FAN to select high, med., or low speed.

Step Four: Press UP or DOWN to select temperature.

Step Five: If operating more than one zone, press ZONE and repeat steps 2-4 for each additional zone.

\*Expect a 2-minute delay for compressor to start.

Shutdown: If you turn the Comfort Control off or if there is a power interruption for any reason, the system will resume operation on the last settings when power returns.

## Ceiling Air Conditioning Ductwork

The unique design of the ceiling in your Mountain Aire changes the arrangement of the roof A/C ductwork from conventional motorhomes. The large circular panels are hinged to allow you drop them down to access and clean the return air filters.

The ductwork is accessed by using your finger to gently pull the two release levers downward (release them one at a time while supporting the panel with your free hand to prevent it from dropping suddenly). Once the ceiling panel has released, let it swing gently down to rest on its retaining straps. You can snap the return air louvers down to access the filters.

## Heating – TwinTemp (if equipped)

### WARNING

Never attempt to modify this furnace. Fire, explosion, asphyxiation, or carbon monoxide poisoning may occur. If the furnace malfunctions, consult a trained service technician.

## Operating Instructions

### To Operate the *TwinTemp* (if equipped):

*TwinTemp* Hydronic Heating/Water Heating Operating Instructions (for more detailed instructions, please refer to the *TwinTemp* Operation Manual, or visit [www.Precisiontemp.com](http://www.Precisiontemp.com)).

For maximum heat and hot water output, it is recommended to use the LPF mode of operation in addition to the 120 volt electric element. Electric element operation should be used for minimal hot water demand such as washing hands or dishes. It is not necessary to have the water system filled to use the space heating system, but the heating system must be filled with anti-freeze.

### To Start Up System:

- i Turn on the propane supply.
- i Turn on 12 volt power switch on the right side of the unit.
- i Turn on 12 volt power switch on coach.
- i Burner will start up and system will be up to operating temperature in about 10 minutes.

### Space Heating

- i Turn on main thermostat and set to desired temperature.
- i Blowers will turn on and heat is delivered within about two minutes.
- i System and blowers will cycle to maintain set temperature.

### Hot Water

- i Turn on water system pump power switch located near galley or connect to city water system.
- i Turn on hot water tap.

**Note:** During heavy heat and hot water demand, the hot water system takes priority and the blowers may shut off briefly to maintain hot water supply. Hot water temperature is factory set. To change temperature, consult the Operating Manual or *PrecisionTemp*.

### To Use With 110 Volt Power

- i Turn off 110 volt element switch located inside coach.
- i Let the unit heat up for approximately 30 minutes.
- i Follow the first 3 steps of “To Start Up System” above.

**Note:** In the 110 volt mode of operation, the electric element supplies the heat until demand exceeds its capacity at which time gas burner automatically ignites.

## WARNING

**WARNING** Use caution when washing the exterior of your vehicle. Water should not be sprayed directly into the furnace vent. If water is forced beyond the rain baffles into the furnace vent, rusting of the furnace could occur. This could also cause improper combustion.

## Heating - Oasis (if equipped)

For your comfort, your new Mountain Aire may be equipped with the Oasis heating system. This system uses a “boiler” and a pump to heat and re-circulate hot fluid through a series of convectors placed strategically throughout your unit. Fans located on the convectors provide circulation of the warmed air for more even, efficient heating.

The Oasis system uses two different sources for heat. The first, and most efficient, is the diesel burner. This uses diesel fuel from the motor homes fuel tank to burn and create heat. The second heat source is an electric heating element. It is important to note the difference in the two systems.

The output of the diesel burner is 50,000 BTU’s. This is the primary heat source for the Oasis system. The electric heating element has a 5000 BTU output, and should be used only to help maintain the temperature once the diesel burner has brought the system up to proper operating heat levels. From a cold start, the 5000 watt electrical heating element will not operate the system alone.

For heating, your unit is divided into three “zones” on your Comfort Control thermostat. The “Furnace” mode will appear in all four zones, but only three are active. They are as follows:

**Zone 1: Dash and Kitchen Convectors:** These convectors are located under the dash and kitchen cabinets, and control heat in the dash, living room, and kitchen areas. Note that the dash mounted convector is the only one in your unit that has a two speed fan. The switch controlling the fan speed is located in the front overhead cabinet adjacent to the diesel boiler switch.

**Zone 2: No Furnace Operation:** There are no “Furnace” functions on this zone.

**Zone 3: Bathroom Convectors:** These convectors are located in the bathroom cabinetry and stool room. Please note that the fan switch for the stool room (marked “HEAT”) must be in the “ON” position to get heat in the stool room. It should also be noted that for Stool Room heat, a “rear” zone (bathroom or bedroom areas) must be chosen on the CCC thermostat.

**Zone 4: Bedroom Convectors:** These convectors are located throughout the cabinetry and walls of the rear bedroom area.

To activate the Oasis heating system, select your heat source, either diesel or electric, using the switches in the front overhead cabinet.

Once you have selected your heat source (diesel or electric), and the boiler is operational, Comfort Control Thermostat to select “Furnace” in the zones you want to heat. Remember, as described above, Zone 2 will display a “Furnace” function, but the thermostat controls no functions in Zone 2 when in the “Furnace” mode.



### IMPORTANT

**The Oasis “diesel burner” heat source provides approximately 50,000 BTU’s of heat, and is designed to start up and operate the system to its full capacity. The electrical heating element provides approximately 5000 BTU’s of heat.**

The system will turn convector fans off and on according to the temperature settings in all but two locations. In those locations, the fan control is separate for independent operation. The first location is at the dash. The convector fan under the dash is operated by a switch in the front overhead compartment. It has settings for on, off, and speed selections.

The second convector fan that is controlled independently is in the “stool room” in the bathroom area. It is controlled by the wall switch labeled “Heat”, and allows the occupant to tailor the room temperature to their comfort separately from the rest of the bathroom.

## Propane Tank

This unit is equipped with an ASME (American Society of Mechanical Engineers) approved propane tank. This tank is controlled with an automatic pressure regulator. The propane tank contains liquid petroleum gas under high pressure. As the fuel is used, the liquid gas vaporizes and passes through the tank valve to a regulator that automatically reduces the pressure. The low-pressure gas is then distributed to the appliances throughout the pipe manifold system. Improperly adjusted regulators are the major cause of appliance lighting problems. Never attempt to reset the regulator. This is to be done by a qualified service technician. While in high altitudes or extreme cold weather a gas shortage may be experienced. Running one appliance at a time can help adjust to this problem.

It is recommended to have the propane system inspected by an authorized service technician at least once a year and after every extended trip. This system is tested by both the manufacturer and the dealer. Leaks can be caused by travel vibrations; therefore routine inspections are recommended.

The primary gas supply manifold is a black steel pipe running the length of the unit. Most secondary lines leading to the gas appliances are made of copper tubing with flare fittings. If any of these lines rupture, do not attempt to splice them. Always have a new line run. Gas distribution work must be performed by an authorized service technician. When removing or servicing any gas appliance, close the main gas valve at the propane tank. This will prevent dangerous gas leakage that could result in an explosion and possible serious injury. If a gas leak is suspected, have the system inspected and repaired by a qualified service technician as soon as possible.

### WARNING

The main gas valve must be shut when the vehicle is not in use. Shut the valve off when refueling to avoid potential danger from pilot lights igniting fuel fumes. Gas valves on appliances with direct spark ignition (DSI) should also be in the off position. Do not store propane, gasoline, diesel, or other flammable liquids inside the vehicle. Fire or an explosion could be the result of ignoring this warning.

## Propane Tank Filling

Do not fill the tank to more than 80 percent of capacity. The unit must be level when filling the propane tank. If not level, overfilling may occur. Fire or explosion may be the result of uncontrolled gas flow from an overfilled tank.

## Propane Regulator

The regulator is the heart of the propane system. The regulator reduces the pressure of the gas so it is safe to use with various appliances. Regulators are equipped with a vent. In the event excess pressure builds up in the body of the regulator, a relief mechanism vents it to the atmosphere. It will vent until the pressure returns to the normal range. The vent must be kept clean and clear of obstructions or corrosion. A clogged vent could cause the failure of components. Contact a qualified propane technician if corrosion or obstruction is noticed.

The presence of moisture in propane fuel causes the regulators to freeze. The moisture will pass through the cylinder valve and into the regulator where freezing occurs. To help prevent the regulator from freezing, always keep the tank control valve closed when not in use, even when the tank is empty, to prevent moisture from collecting on the inside.

If moisture becomes a problem, consult an authorized propane service center for assistance.

The regulator must always be installed with the diaphragm vent facing downward. Please refer to Chapter 2 of this manual for further propane gas safety information.

## Propane Leak Detector

### WARNING

Never check gas lines for leaks with an open flame. Do not check for leaks using ammoniated or chlorinated household type detergents. These detergents can cause cracks to form on the metal tubing and brass fittings. Take the unit to a qualified propane gas service technician to find and repair the leak. Keep the tank valve closed and all of the appliances turned off when the unit is stored. If any of the propane gas valves do not close leak-tight by hand, consult a service technician.

Liquid propane (propane) gas is heavier than air and will settle to the lowest point of the room, which is generally on the floor of your coach. Because of this, the propane detector installed in your coach is located near the floor. The detector is also sensitive to other fumes, such as hair spray, which contain butane as the propellant. Butane, like propane, is heavier than air and will settle to the floor level where it may be detected. When this occurs, press the reset button to stop the alert sound for 60 seconds.

The detector is equipped with a “sensor activation strip.” This strip must be removed for the detector to operate properly. This should have been done during the dealer’s Pre-Delivery Inspection. Please check the detector to verify that the activation strip has been removed.

Please consult your propane detector User’s Guide for more detailed information.

## MAJOR APPLIANCES

### Refrigerator

Before starting the refrigerator, verify that the main propane gas valve is in the on position. The refrigerator is equipped with a semi-automatic energy selector (AES) control system. It can be set to select either 120 volt or propane gas operation, automatically, if desired.

A 12 volt power supply must be available for the electronic control panel to function. The shore line must be plugged in, or the optional generator running, to operate in the 120 volt mode. The main propane gas valve must be open for operation in the propane mode. To start the refrigerator, press the main power ON/OFF button to the ON position.

### WARNING

Most propane gas appliances used in recreational vehicles are vented to the outside of the vehicle. When parked close to a gasoline pump it is possible that the gasoline fumes could enter this type of appliance and ignite the burner flame causing a fire or explosion. Use caution when refueling.

To use the 2-way Auto Mode, push the AUTO/GAS mode selector into the ON position. If 120 volt is available, the AC mode indicator light will be illuminated designating AC operation. If 120 volt is not available, the gas mode indicator light will be illuminated. The control system will automatically switch to gas operation. To operate on gas only, push the AUTO/GAS mode selector until the gas indicator light has lit. After 45 seconds the burner should be ignited and operating normally. The initial start up may take longer than 45 seconds in order to allow the air to be purged from the gas line. If the gas does not ignite within 45 seconds, the check indicator light will illuminate and the gas mode light will go off. If the check indicator light illuminates and the gas mode

indicator light is off, then the controls have failed to ignite the burner in the gas mode. When the check indicator light is on, press the main power ON/OFF button to the off position to reset. Do not continue to reset the gas operation if the check indicator light continues to illuminate after several tries.

The thermostat on the refrigerator controls the gas and electric operation. This eliminates the necessity of resetting the temperature each time a different energy source is used. Press the temperature selector button until the light at the desired setting is illuminated. After the initial start up, the thermostat should be moved from the coldest setting to the desired setting, which is usually mid-range.

An optional feature on the refrigerator may be the installation of the automatic icemaker in the freezer compartment. Depending on the floorplan of your unit, additional refrigerator options may include a four-door refrigerator, a 10 cubic foot refrigerator, or a side-by-side refrigerator. For detailed operating instructions, please consult the manufacturer Owner's Manual in the Owner's Information Package.

## Microwave

A microwave oven is installed in your coach as part of the standard equipment package. In place of the standard microwave, a 30" convection microwave may be optioned. All microwaves operate on 120 volt electricity. The microwave's control panel is the touch pad type. Simply enter the temperature, mode, and cooking time desired. For instructions on how to operate any of the special features on the microwave oven, please refer to the microwave Owner's Manual in your Owner's Information Package.

## Range Hood

A range hood may be incorporated into the microwave oven. The microwave's control panel operates the range hood functions. This range hood has both a fan and a light for your convenience. The fan has two speeds which are low and high. Simply select the desired setting from the microwave's control panel. For further detailed information on the hood operation, refer to the microwave Owner's Manual.

## Range

Your unit may be equipped with a three-burner recessed range with a glass oven door and piezzo ignition. There is no pilot light for the range. There are different models used in the Newmar product line with different types of controls. To light the burners on some models, turn the control knob to turn the gas on. Wait a couple of seconds, and then push the red spark button until a flame appears. On other models turn the spark control knob until a flame appears. All burner controls operate counter clockwise and have to be pushed inward in order to turn. On units with an oven, the oven control must also be pressed inward before turning. To light the oven, push in the oven control knob and rotate counter clockwise to the PILOT ON position. Light the oven pilot light located at the back left-hand side of the oven burner. The oven pilot may be slow in lighting due to initial air in the gas line. The oven pilot has been factory adjusted. No further adjustments are necessary. To extinguish the oven pilot, push in the oven control knob and turn clockwise to the "Off" position.

### WARNING

It is not safe to use cooking appliances for comfort heating. Cooking appliances need fresh air for safe operation.

Before operation:

1. Open overhead vent or turn on an exhaust fan.
2. Open a window.

Unlike homes, the amount of oxygen supply is limited due to the size of the recreational vehicle. Proper ventilation when using the cooking appliance(s) will avoid dangers of asphyxiation. It is especially important that cooking appliances not be used for comfort heating as the danger of asphyxiation is greater when the appliance is used for long periods of time.

Your range may be equipped with a bi-fold range cover that matches your countertop material. This cover helps to protect the burners when they are not in use. Before cooking on the range top, the cover must be in the full upright and folded position, preventing the cover from falling on the range top during cooking.

Never close the cover while the burners are in use and do not use the cover as a griddle. Never use the range while the RV is moving and remember to close the bi-fold cover when the range top is not in use.

For further instructions, please refer to the oven manufacturer Owner's Manual in your Owner's Information Package.

The following warning label has been placed in the cooking area to remind the user to provide an adequate supply of fresh air for combustion:

The following label has been placed in the vehicle near the range area:

### **If You Smell Gas:**

- 1. Extinguish any open flames, pilot lights, and all smoking materials.**
- 2. Do not touch electrical switches.**
- 3. Shut off the gas supply at the tank valve(s) or gas supply connection.**
- 4. Open doors and other ventilating openings.**
- 5. Leave the area until the odor clears.**
- 6. Have the gas system checked and leakage source corrected before using again.**

## **Television Antenna**

A TV antenna with a power booster is installed in your coach and is designed for reception of all color and black-and-white channels. If the reception is poor, you should verify that the power switch is in the "ON" position and that all of the connectors are tight. If poor reception still occurs, consult your authorized dealer.

To raise the antenna into the operating position, turn the elevating crank (clockwise) in the "UP" direction, about 13 turns, or until some resistance to turning is noticed. On the power booster, turn the switch to "ON" in order to amplify the signal being received. Once in the "UP" position, rotate the antenna to receive the best picture. This is done by pulling down on the directional handle with both hands until it disengages from the ceiling plate and then rotating it until reception has improved. The antenna must be lowered before moving the vehicle. To lower, rotate the directional handle until the pointer is aligned with the pointer on the ceiling plate. Turn the elevating crank (counter-clockwise) in the "DOWN" direction, about 13 turns, or until some resistance to turning is noticed. The antenna is now locked and in the travel position. Your unit may be equipped with one exterior antenna jack and two interior antenna jacks.

**RAISING ANTENNA TO OPERATING POSITION**

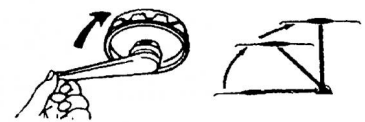

**ROTATING ANTENNA FOR BEST PICTURE**



**LOWERING ANTENNA TO TRAVEL POSITION**



### **CAUTION**

**Under no circumstances should you lower the antenna in any position except the travel position.**



## Television

The coach is cable ready, and (depending on floorplan) as standard equipment may have a flat panel color television in the living area cabinetry, and a flat screen color television in the bedroom. The televisions are powered by 120 volt electricity. Your coach must be plugged into shore power, have the generator running, or have the inverter operating in order for the television to work.

For more information on this, see Chapter 4 of this manual. The television operation is similar to most televisions used in the home. The main unit has the basic ON/OFF, Volume UP and DOWN, Channel UP and DOWN, and Menu UP and DOWN. The remote control has these in addition to many other function keys. Your unit may also be pre-wired for a satellite system. Your unit may be equipped with one interior television jack and an exterior television jack located on the door-side of the coach. Please consult your television Owner's Manual for further information. As an option, an external entertainment center that includes a flat screen television and an AM/FM compact disc player and radio may be added. All TV source selection is achieved through the TV's input selection mode. Please refer to the television's Owner's Guide for additional information. The Living area DVD and Satellite, if equipped, provides input to the front TV(s) and Exterior Entertainment TV, if installed. The Bedroom area DVD and Satellite receiver, if equipped, provides input into the Bedroom area TV.



### IMPORTANT

**TV's in the front overhead cabinet will not operate when in transit. Federal regulations require these TV's be inoperative while the vehicle is in use, so the power supply to this TV is switched off automatically when the ignition is on.**

To enhance the entertainment experience in your unit, a DVD and Surround Sound Stereo Receiver system may be installed. This system allows you to enjoy music, TV, or videos from DVD through a matching set of speakers, complete with a subwoofer for deep, full bass sound. This system has its own remote, and detailed operating instructions can be found in the manufacturer's literature that was provided with your unit.

## Stereo

For detailed operating instructions on either system, please refer to the directions and information provided by the radio manufacturer.

## Exterior Entertainment Center (optional)

Your unit may be equipped with an optional Exterior Entertainment Center, located in a basement compartment on the passenger side, just forward of the rear wheels. This Entertainment Center has a flat panel television mounted on a pivoting "swing arm" that allows you to rotate the TV for optimum viewing. Simply grasp the TV and pull it toward you to release it. Return it securely to the stored position prior to closing the compartment door and traveling. Programming is provided to this television through the main satellite receiver/DVD found in the Living area.

The Exterior Entertainment Center also incorporates a stereo system that allows you to enjoy music, or TV sound through the exterior speakers.



### IMPORTANT

**It is important to make sure the TV is securely locked into position prior to closing the compartment door. Failure to do so can result in damage to the TV case and screen.**

## CB Radio & Antenna (Optional)

This coach may have a citizens band (CB) radio and antenna installed as an option. This system allows easy CB radio communication with other travelers on the road. The system uses an “all-in-one” handset that allows you to control channel selection and volume of the system from one convenient hand held component. Please refer to the manufacturers operating instructions for additional information.

## Rear View Monitor System

Installed as a standard feature, the rear view monitor system assists the driver in the backing and parking of the vehicle. This system consists of a camera mounted on the rear cap and a monitor located on the dash. This system is viewed through the in-dash stereo, when the video display is open and operating. On units that are not equipped with a factory installed navigation system, there will be a switch located on the dash labeled “Back Up Camera” that will allow you to view the rear vision camera any time the display is open and operating. The system also features an automatic function that turns the rear vision system on any time reverse is selected on the transmission.

On systems with a factory installed navigation system, the display will be in a “split screen” form any time the rear vision system is selected while the navigation system is in use.

## Air Horns

Air horns may have been installed on this coach as a standard feature. These air horns are in addition to the horn installed on the chassis. A switch located on the dash allows you to choose either the chassis horn or the air horn. To operate either horn, press the center of the steering wheel.

## Freezer (Optional)

The installation of a 100 pound freezer in an exterior storage compartment is an optional feature on this coach. This freezer operates on 12 volt and 120 volt electrical power. The freezer is on slides to move easily in for storage while traveling or out for pre-travel packing or campsite unloading. For detailed instructions on the operation and maintenance of this freezer, please consult the freezer manufacturer Owner’s Manual in the Owner’s Information Package provided with this coach.

## Icemaker (Optional)

Depending on the floorplan of your unit, an icemaker may be an option. The icemaker operates on 120 volt electricity. For detailed information, consult the icemaker manufacturer Owner’s Manual in the Owner’s Information Package provided with your new coach.

## Washer/Dryer (Optional)

The plumbing and other preparations for the installation of a compact one-piece washer and dryer are standard features on this coach. To have the washer and dryer factory installed is an option. The washers and dryers used by Newmar function as those in a home, operating on 120 volt electricity. For more detailed information on the operating instructions, read the appliance Owner’s Manual in the Owner’s Information Package.

### CAUTION

The gray tank valve must be in the “open” position when operating the washing machine.

## Carbon Monoxide Detector

Carbon monoxide is a colorless, tasteless, odorless gas. It is a by-product of the burning of fossil fuels (gasoline, propane gas, diesel fuel, etc.). The chassis and generator engines, furnaces, water heater, propane gas refrigerator, and range produce carbon monoxide constantly while they are operating. **Carbon monoxide is DEADLY.** Please read and understand the following precautions to protect yourself and others from the effects of carbon monoxide poisoning.



If you, or anyone else, experience any carbon monoxide symptoms (dizziness, nausea, vomiting, muscular twitching, throbbing in the temples, inability to think coherently, weakness and sleepiness, or intense headaches) exit the coach immediately. Seek medical attention if symptoms persist. Shut down the unit and do not operate it until it has been thoroughly inspected and repaired.

### WARNING

**Exhaust gases are deadly. Do not block the tailpipes or exhaust ports. Do not situate the vehicle in a place where the exhaust gases have any possibility of accumulating either outside, underneath, or inside your vehicle or any nearby vehicles. Outside air movements can carry exhaust gases inside the vehicle through windows or other openings remote from the exhaust outlet. Operate engines, carbon monoxide-producing systems, or components only when safe dispersion of exhaust gases can be assured. Monitor outside conditions to be sure that exhaust continues to be dispersed safely. UNDER NO CIRCUMSTANCE SHOULD YOU OPERATE ANY ENGINE WHILE SLEEPING. When you are sleeping you will not be able to monitor outside conditions to assure that engine exhaust does not enter into the coach. Check the exhaust system frequently for damage. If damage is found, do not operate the system. Never modify the exhaust system(s) in any way.**

The detector is equipped with a “sensor activation strip.” This strip must be removed for the detector to operate properly. This should have been done during the dealer’s Pre-Delivery Inspection. Please check the detector to verify that the activation strip has been removed.

Please consult your carbon monoxide detector User’s Guide for more detailed information.

Chapter 4

CABINETS, FURNITURE & INTERIOR FEATURES

CABINETS.....3  
    **Pull Out Kitchen Extension/Island (optional)**..... 4

FURNITURE..... 4  
    **Kitchen/Dinette Area**..... 4  
    **Living Room Furniture**..... 4  
    **Bedroom Area** ..... 5

INTERIOR FEATURES.....5  
    **Bedsread** ..... 5  
    **Flooring** ..... 5  
    **Ceiling**..... 5  
    **Window Treatment**..... 5  
    **Safe**..... 5



# CABINETS

## WARNING

Prior to driving your vehicle, be sure you have properly secured all interior items for travel. Examples would be (but not limited to):

- 1) **Furniture (tables, chairs, etc.)**
- 2) **Personal belongings (plates, glasses, cooking utensils, pots, books, etc.)**
- 3) **Accessories (slide out pantries, cabinet doors, optional slide out island, sink covers, etc.)**

It is very important to be certain the interior of your unit is safe for travel by making sure all loose items are stored safely and securely. It is also important to be sure the items stored in your cabinets are secure to minimize the possibility of them shifting in the event of an emergency maneuver, such as sudden braking or turning. Always use caution when opening a cabinet door or drawer after traveling as the contents may have shifted in transit.

The cabinetry in your RV is constructed on-site at the Newmar Production Facility. Oak hardwood raised panel doors are standard throughout the unit. Brass or nickel door and drawer handles give the interior an added touch of elegance. The standard cabinets in your unit are finished in oak vinyl veneer. Your unit may be equipped with the optional hardwood cabinetry in a variety of finishes. Your cabinetry was designed with function and convenience in mind, and was built to exacting standards by modern craftsmen.

Storage is an important factor to all RV owners. Keeping this in mind, the cabinetry is structured to provide as much storage as possible. Your unit may include features such as adjustable pull out pantry boxes in the kitchen or the silverware drawer may have a molded silverware divider tray for added storage. In the bedroom, the bed platform lifts to provide an additional, convenient storage area. A strap is provided to help raise the bed. Once the bed platform is lifted, it is held open by pressurized struts to allow hands-free access.

A countertop with a color coordinated edge is installed in the kitchen. To clean, wipe with a damp cloth and for “dried on” spots or rings, wipe with a damp cloth and a mild liquid soap. Strong chemicals and solvents may damage the surface and should be wiped up immediately, then rinse the surface with water.

Avoid cutting directly on the countertop surface, avoid excessive heat, and keep harmful chemicals away to avoid countertop surface damage.

On most floor plans, the “drawer” directly in front of the kitchen and lavatory sink does not pull out, but rather flips down. This provides a storage tray for dish cloths, scouring pads, washcloths, etc.

Metal drawer guides are installed on the drawers in your unit. These guides provide a smooth opening and closing of the drawers. To open a drawer, lift up slightly and pull open. The drawer guide mechanism is designed to prevent the drawers from unintended opening while traveling.

All of the cabinetry can be easily cleaned with any commercial furniture cleaner or polish. As with any wood product, do not saturate these cabinets with water or any other liquid. Be sure to wipe up spills as they occur to avoid staining.



## Pull Out Kitchen Extension/Island (optional)

Your unit may be equipped with an optional pull out Kitchen Extension, or Kitchen Island. The “extension” is incorporated directly into the kitchen cabinetry, and glides out on drawer guides to provide additional counter space when needed. If your unit is equipped with the optional pull out “island”, the complete cabinet will pull completely free of the kitchen cabinetry and can be moved throughout the unit on the attached casters.



### WARNING

The optional pull out kitchen extension/island **MUST** be secured back into their stored position in the kitchen cabinetry **PRIOR** to travel. The “island” will roll back over a stop, and the front casters have locks to inhibit their movement. The “extension” features a locking mechanism activated by a lever accessed by opening the top drawer. Failure to lock the island/extension into place in transit can cause damage to the cabinetry and interior of your unit, and under certain circumstances, injury or death.

The bathroom may feature a pull out step/storage bin in the bottom of the lavatory cabinet. This convenient step allows younger children better access to the sink and mirror. The hinged top provides a platform on which they can stand, while still allowing for storage underneath.



## FURNITURE

### Kitchen/Dinette Area

A standard feature in the kitchen area is the hidden leaf dinette table. This table allows you to add more room to your table top when desired. Two fixed chairs and two folding chairs accompany this table. The chair seats are designed with a coordinating upholstery fabric to match your décor.

Depending on the floorplan of your unit, a built-in “booth” style dinette may be an option.

### Living Room Furniture

Covered in coordinating fabrics and accented with pillows, the sofa will fold flat to provide additional sleeping space. To fold the sofa out to the sleeping position, lift and pull on the front of the sofa seat cushion. The seat cushions will swing out and the seat back will slide down to form the sleeping surface.

Depending on the floorplan and options, a variety of living room furniture is available in the Mountain Aire. Options may include a free standing leather/vinyl recliner, a leather/vinyl push back recliner with an ottoman, a leather/vinyl swivel rocker recliner, or a leather/vinyl “L”-lounge.

The driver and passenger seats in the Mountain Aire are covered in leather, and feature six-way power position adjustment, lumbar support, and a passenger footrest. The base moves the chairs forward and backward, as well as up, down, and forward and reverse tilt. The seats also have a three-point seat belt and swivel and recline features. When the unit is not in motion, they can be swiveled to face the living room of the unit. To turn the chairs, first extend the slide out room. Tilt the steering wheel up and toward the dash. Reposition the seat to provide enough clearance for the steering wheel. Once this is done, the chairs will swivel without interference. The power lumbar control switch is located on the left-hand side in front of the power base controls. Pushing the switch forward will inflate the support while pushing back will deflate it.

## Bedroom Area

A “king size” bed is standard in most Mountain Aire floorplans. A decor coordinating quilted bedspread with a reverse sham and accent pillow(s) may be included as part of this unit’s standard bedroom package. For best results, it is recommended that the bedspread be **DRY CLEANED ONLY**.

For your convenience, lights have been added in the closets and wardrobes.

## INTERIOR FEATURES

### Bedsread

A decor matching Duvet with coordinated pillow shams and an accent pillows are part of the standard package for this unit. The recommended cleaning instructions for this spread are **DRY CLEANED ONLY**. The materials that make up the spread may have been treated, and dry cleaning will preserve this treatment.

### Flooring

The floor covering throughout the living room and bedroom of the unit is nylon tufted cut loop carpeting. In the Owner’s Information Package you will find literature supplied by the carpet manufacturer. This information will be helpful in maintaining and extending the life of the carpet. Please refer to this information for the carpet or hard surface flooring care and cleaning instructions. Simple vacuuming is all that is necessary to remove loose dirt and debris for everyday cleaning. Mop occasionally, using a minimal amount of water. Abrasive cleansers and scouring pads can scratch and damage the surface also.

### Ceiling

The ceiling in this unit is covered with a padded vinyl ceiling headliner. It is cleaned by wiping gently with a soft cloth and a mild detergent. **DO NOT** saturate the material, and wipe it dry when finished cleaning with a soft, dry cloth.

### Window Treatment

The window treatment throughout this unit, except in the kitchen, is pleated day/night window shades and lambrequins. These shades have two sections. The first section visible when closing the shade is the “DAY” section. This material is translucent. Sunlight passes easily through the material into the unit. The second visible section is the “NIGHT” section. This material is a heavier, more opaque material. Very little to no light passes through it. It is generally used in the evening or when more privacy is desired, though under certain light conditions, it can cast shadows and silhouettes. If any curtains are installed in this unit, cleaning instructions are **DRY CLEAN ONLY**. Water-based products are not recommended for cleaning fabrics. Water-based products may cause excessive shrinkage or fading.

### Safe

Your unit may be equipped with a built in fire resistant “safe box/file cabinet”. If so equipped, it is located under your bed. This is accessed by raising the bed base/mattress platform. The key for the lock is included with your unit at the time of delivery.





# Chapter 5

## ELECTRICAL FEATURES

ELECTRICAL SYSTEMS.....	3
<b>General Information .....</b>	<b>3</b>
<b>Breaker Boxes.....</b>	<b>3</b>
<b>Batteries .....</b>	<b>4</b>
<b>Battery Inspection &amp; Care .....</b>	<b>4</b>
<b>Battery Disconnect Panel.....</b>	<b>5</b>
<b>12 Volt Receptacles .....</b>	<b>5</b>
<b>120 Volt Receptacles .....</b>	<b>5</b>
<b>Ground Fault Circuit Interrupt Receptacles .....</b>	<b>6</b>
<b>ICC Flasher .....</b>	<b>6</b>
<b>Inverter/Converter.....</b>	<b>6</b>
<b>Generator.....</b>	<b>6</b>
<b>Automatic Transfer Switch.....</b>	<b>7</b>
<b>Wiring Connector.....</b>	<b>7</b>



# ELECTRICAL SYSTEMS

## General Information

There are two electrical systems in your coach. They are the 12 volt DC system and the 120 volt AC system. Most standard appliances require 120 volt electricity while the majority of the lighting used in recreation vehicles is powered by 12 volt electricity. The power for the 12 volt system is supplied by the coach batteries, which are charged by two 45 amp power converters. The power for the 120 volt systems is supplied by the power cord when the unit is connected to an outside power source or by the generator. If installed, the optional inverter can also supply 120 volt power. It will transform 12 volt electricity from the batteries into 120 volt power for basic appliances.

### CAUTION

**Failure to turn off the 120 volt appliances when starting or stopping the generator may damage the transfer switch and/or electrical appliances.**

### WARNING

#### **Use of “Adapter” cords with the RV shore power cord.**

**All Newmar units are manufactured with either a 30 or 50 amp electrical breaker box and electrical system. A unit with a shore power cord that has 3 prongs on it has 30 amp service; if the shore power cord has 4 prongs, it has 50 amp service. To provide the correct amperage into the RV and to assure the operation is as designed, it is important that they be plugged into the correct type of properly grounded receptacle. The receptacle MUST be properly grounded to insure safe, proper operation of all electrical components.**

NEWMAR CORPORATION DOES NOT RECOMMEND USE OF “ADAPTER”, “CHEATER”, OR “DOG BONE” STYLE CONNECTORS THAT WILL MODIFY THE EXISTING SHORE POWER CORD TO A DIFFERENT STYLE OF OUTLET. USE OF THIS TYPE OF ADAPTER WILL GREATLY REDUCE THE AMOUNT OF AVAILABLE CURRENT IN THE UNIT, AS WELL AS CREATES THE POTENTIAL FOR ELECTRICAL FAILURE AND/OR FIRE. NEWMAR CORPORATION CANNOT ASSUME LIABILITY FOR FAILURES OCCURRING TO THE RV, ITS ELECTRICAL SYSTEM, OR ANY OF ITS COMPONENTS FROM THE USE OF ANY ELECTRICAL ADAPTER.

To connect the unit to 120 volt shore power, first make sure all of the breakers are in the off position. This is done to avoid a power surge. Unwind the power cord from the electrical compartment. The standard electrical service in this unit is 50 amps with a flexible cord. Check to make sure the pins in the outlet are oriented correctly, that they match the power cable, and that they are in good condition. If there is a circuit breaker switch at the plug, it should be turned OFF before making the connection. Insert the plug completely into the outlet and turn the circuit breaker on. Close and lock the electrical compartment door to keep the contents clean, dry, and secure. Close the cover on the power box, if equipped, to avoid an unintended disconnection and to keep contents clean. Switch the main breaker to the ON position. The 120 volt system will energize all 120 volt circuits and outlets when the main breaker is turned on.

## Breaker Boxes

The 120 volt and 12 volt breaker boxes are generally located in the overhead cabinet on the rear bedroom wall, or in a cabinet in the bathroom. Circuit breakers and fuses are installed to protect the electrical system from overloading. Do not attempt to change the circuitry or add appliances yourself. Please consult an authorized Newmar Service Center.

## Batteries

The chassis batteries on your motorhome are installed and warranted by the chassis manufacturer. The four 6 volt coach (or house) batteries on your motorhome are installed by Newmar Corporation, but warranted by the battery manufacturer. These batteries are used to operate the 12 volt items that are not a direct part of the chassis. They are located on a pull out tray in an outside compartment.

### CAUTION

**Do not use the motorhome with the coach batteries disconnected.**

The coach and chassis batteries are recharged by the vehicle's electrical system whenever the engine is running. A decline in the coach battery voltage may be noticed while the chassis batteries are being charged. The converter will automatically charge the coach batteries when the unit is connected to a 120 volt outside power source, then the chassis batteries when the house batteries are fully charged. The chassis batteries are isolated from the coach batteries. This prevents the chassis batteries from being drained by the interior 12 volt equipment, allowing ample voltage for engine ignition.

### **Battery Boost Switch**

The battery boost switch is located on the dash. This switch briefly connects the coach batteries to the chassis batteries. This allows the chassis batteries to borrow power from the coach batteries to assist in starting the engine. If the chassis batteries cannot turn the engine over in the normal mode, hold down the battery boost switch and attempt ignition. By using the battery boost switch while trying to start the chassis engine, a jump start situation is created between the coach and chassis batteries. If the battery boost switch is required to start the engine on a regular basis, ask your dealer to check the chassis batteries and charging system.

## Battery Inspection & Care

### WARNING

**Remove rings, metal watch bands, and other metal jewelry before working around batteries. Use caution when using metal tools. If a tool contacts a battery terminal or metal connected to it, a short circuit could occur which could cause personal injury, explosion or fire.**

### CAUTION

**Disconnect the 120 volt electrical power cord and the negative terminal from the coach batteries before working on the electrical system.**

Remember that when batteries are not used for an extended period of time, they may lose their charge. Periodic charging of the batteries during storage of the unit will increase the life of the battery. Check the external condition of the battery periodically. Look for cracks in the cover and case. Check the vent plugs and replace them if they are cracked or broken. Keep the battery clean. Accumulations of acid film and dirt may permit current flow between the terminals, which could drain the battery.

To clean, wash the batteries with a diluted solution of baking soda and water to neutralize any acid present. Rinse thoroughly with clean water. Foaming around the terminals or on top of the battery is a sign that acid is being neutralized. Avoid getting the baking soda solution in the battery. Secure all vent caps. Dry the battery cables and terminals to prevent corrosion. Do not use grease on the bare metal inside the cable terminals.

Grease can act as an insulator, and electricity will not flow through it. A plastic ignition spray will protect the terminals after they have been cleaned.

## WARNING

**Do not allow the battery fluid to contact your skin, eyes, fabric, or painted surfaces. The fluid could cause serious personal injury or property damage. Wear eye protection when working with any battery.**

The batteries should be removed and stored in a warm place when not using your motorhome for an extended period of time. Mark the cables, positive and negative, for easy identification. Batteries are not to be stored on concrete floors. The batteries require periodic charging during storage. If the motorhome is to be stored for a long period of time, it is recommended that all of the batteries inside the unit be removed from clocks, radios, smoke alarms, etc. This will prevent unnecessary drain and corrosion of the batteries. The coach batteries are 6 volt RV/Marine deep cycle batteries. This type of battery consumes water and must be filled periodically. Please be sure to check the battery water level on a regular basis. Consult the Owner's Manual supplied by the battery manufacturer. This can be found in the Owner's Information Package received with this unit.

### Battery Disconnect Panel

The battery disconnect panel for house batteries is located above or near the entrance door. There are two switches on the panel. The top switch is used to measure the battery voltage. The lower switch is used to disconnect the battery when the unit is stored for any period of time. Pressing downward disconnects the coach batteries, not the chassis batteries. This is done to prevent the coach batteries from being drained during storage. It disconnects all of the 12 volt circuitry from the batteries, with the exception of the LP detector. When taking the unit out of storage, press upward to re-connect the batteries. This will make the 12 volt system ready for use.

Depending on the chassis of the coach, diesel pusher motorhomes may be equipped with a second disconnect switch strictly for the chassis batteries. If equipped, this "Master Kill Switch" may be located in the rear engine compartment. This switch disconnects all power to the coach so that it cannot be started. It is used to prevent accidental ignition when the engine is being serviced.

### 12 Volt Receptacles

Your unit may be equipped with two 12 volt receptacles conveniently located in the dash area. These 12 volt receptacles can be used for items such as cellular phones or personal computers. As an option, an extra 12 volt interior receptacle may be added to your coach.

### 120 Volt Receptacles

For your convenience, there are 120 volt receptacles located throughout the interior of the unit. As an option, an extra receptacle may be added. These receptacles require three-pin plugs that provide proper grounding to protect you from electrical shock. Do not use an adapter, cheater, or extension cord that breaks the continuity of the ground circuit to the ground pin. Never remove the ground pin from a plug in order to connect it to a two-pronged ungrounded outlet. Never operate the camping vehicle with an electrical short. An electrical short may cause the exterior of the unit to shock you when touched. If you feel even the slightest shock, disconnect the unit from the 120 volt power source. It is usually a break in the grounding circuit. The grounding circuit must be continuous from the frame to the distribution panel, to the power cord, and to the earth ground.

## Ground Fault Circuit Interrupt Receptacles

The 120 volt electrical outlets in the kitchen and bath area are ground fault circuit interrupt (GFCI) protected receptacles. The electrical outlets located in the slide out are wired through the kitchen GFCI. The exterior electrical outlets are wired through the bathroom GFCI. If an item plugged into a slide out or outside receptacle is not working, check for a tripped GFCI in the kitchen or bathroom. These outlets protect the user from ground faults between a hot wire and ground. The GFCI will not reduce the shock hazard if the short is between a neutral and hot wire or two hot load wires.

The GFCI should be tested at least once a month. The 120 volt electrical system must be on in order to test the GFCI. The reset button needs to be pushed in all of the way before starting the test. Push the test button. This will cause the reset button to pop out which means that the protected circuits have been disconnected. Push the reset button back in until a click is heard. This will reactivate the protected circuit. If the GFCI is working properly the reset button will remain in the “IN” position.

## ICC Flasher

On the dash you may have a switch labeled “ICC Flasher.” This switch is a momentary type of switch. This means it is only active while the switch is being pressed. It enables the driver to communicate with other traffic by flashing the clearance and side lights of the coach. If the lights are on, it will turn them off. If the lights are off, it will turn them on.

## Inverter/Converter

When 120 volt power is not available, either from the power cord or the generator, the optional inverter/converter may be used, if installed. The control panel for the inverter is located in the front overhead cabinets. Once turned on, the inverter transforms 12 volt power to 120 volt power for the operation of lights, appliances, televisions, etc. The 120 volt power that is generated from the inverter is routed to the electrical sub-panel located next to the main breaker box in cabinet above the bed.

The breakers in the sub-panel are labeled to explain where the 120 volt power is routed. It generally supplies power to the microwave, kitchen, bath, and selected receptacles. The inverter is equipped with an automatic transfer switch. This allows automatic switching from inverter to DC charger. When you are connected to an outside power source or running the generator, the charge circuitry (in the inverter) will automatically switch on to charge the 12 volt batteries. For more detailed information consult the manufacturer Owner’s Manual located in the Owner’s Information Package.

## Generator

The generator is located in a compartment in front of the motorhome. It is mounted on slides for easy access. The slides for the generator must be unlocked before free movement is allowed. Prior to starting or stopping the generator, make sure all of the 120 volt appliances are turned off. After the generator has started, wait until the transfer switch has connected before turning on any of the appliances. The generator can be started from either the remote start switch located on the dash or directly at the generator itself. The hour meter installed on the generator calculates the number of running hours of the generator motor. This is used for maintenance schedules.

### CAUTION

**Failure to turn off the 120 volt appliances when starting or stopping the generator may damage the transfer switch and/or electrical appliances.**

Consult the manufacturer Owner’s Manual for detailed operating instructions.

## Automatic Transfer Switch

Your unit may be equipped with an automatic transfer switch. When the generator is turned on, this switch automatically transfers from shore power to generator power. There will be a slight delay between the start of the generator and the electrical connection. This delay allows the generator to reach normal operating speed without needing to supply a required load. When the unit is plugged into the outside power source, a click will be heard in the transfer switch box. The sound is normal and indicates that the unit is changing over to the outside power source.

## Wiring Connector

Standard on your motorhome is a 15,000 pound car towing hitch. This allows the consumer the capability of towing their passenger car while traveling. Also installed with the hitch is the wiring pigtail to connect tail lights, brake lights, turn lights, etc. of the towed vehicle with that of the motorhome. The pigtail used is the standard seven-pin connector. The color scheme for the pigtail is as follows:

Stop & Left Turn Signal..... Red  
Ground..... White  
Stop & Right Turn Signal...Brown  
Clearance & Tail Lights.....Green  
Aux. Tow Connector Prep...Black  
Back-up Lights.....Yellow  
Brakes.....Blue

This view is looking into the tow vehicle receptacle.

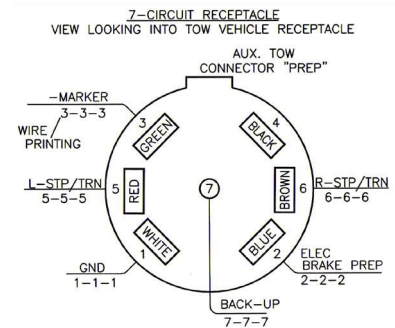





# Chapter 6

## EXTERIOR FEATURES

EXTERIOR FEATURES .....	3
Hitch.....	3
Exterior Sides.....	3
Security Lights .....	3
Head Lamps .....	3
Roof .....	3
Hydraulic Leveling Jacks .....	3
Touch Manual Control Pad.....	4
Electric Steps .....	5
Mirrors .....	5
Windows .....	6
Vents.....	6
Doors .....	6
AWNINGS .....	6
Side Awnings .....	6
Extending and Retracting.....	6
Manual Retraction.....	7
“Oasis” Entry Door Awning .....	7
Window Awnings (optional) .....	7



## EXTERIOR FEATURES

### Hitch

On the rear of this unit you will find a Class Five, 10,000 pound car towing hitch. This is installed for towing passenger cars to be used when the vehicle is parked. The wire connector installed with this hitch is a standard seven-pin connector. For more information on the connector, please see Chapter 5 of this guide.

### Exterior Sides

The sides of this unit are constructed of gel-coated fiberglass. To add to this feature, the end caps are also gel-coated fiberglass. Clean the fiberglass material with a mild cleanser and warm water. Use only soft cloths. Using stiff bristle brushes may cause scratches in the fiberglass surface. Please note; Newmar is not responsible for weathering/oxidation of gel-coated surfaces.

Lighted storage compartments are located on the exterior sides of your unit. These compartments provide additional space for your belongings while you are traveling.

### Security Lights

Standard on this unit are exterior security lights. One is installed on each side of the coach. These lights help to light the side of the unit for added protection. As an option, you may have two lights installed on each side of your unit if you desire.

### Head Lamps

Your new RV is equipped with headlamps that are not sealed. This design features a replaceable bulb assembly and a vent system. As these headlamps are not sealed, they may exhibit, due to condensation, a fine mist or white fog to small droplets of water on the inside of the lamp lens.

Condensation occurs when the air inside the lamp assembly, through atmospheric changes reaches the ‘dew point’. When this takes place, the moisture in the air within the lamp assembly condenses, creating a fine mist or white fog on the inside surface of the lamp lens or chrome reflector surfaces.

Most headlamps are designed to remove any accumulated moisture vapor by expelling it through a vent system. The vent system operates at all times however; it is most effective when the lamps are “ON” and when the vehicle is in motion.

### Roof

Your Mountain Aire comes with either a Fiberglass or “Brite Tech” roof. Proper care and routine maintenance of your roof is necessary for trouble-free performance. See Chapter 9 for cleaning instructions.

### Hydraulic Leveling Jacks



**If the vehicle is equipped with a slide out, it is recommended that the leveling and stabilizing procedure is complete before operating any room extension. Note: The slide out can be operated without utilizing the leveling system, but it is recommended to have the unit as level as possible.**

This unit may be equipped with hydraulic leveling jacks. The jacks work in pairs: front, right side, left side, and rear. Before extending, the engine must be off, the ignition switch must be in the “ACC” position, and the transmission must be in park. The parking brake needs to be set and the tires blocked securely.

## CAUTION

Do not lift the wheels off the ground when leveling. The unit can roll forward or backward when supported only by the jacks.

## IMPORTANT

If the hand/auto park brake is not set, the “NOT IN PARK/BRAKE” light will come on when the “ON” button is pushed. The panel will turn on, but the system will not operate.

### Touch Manual Control Pad

To extend, press the “ON” button on the HWH control panel. The “POWER ON” light will illuminate. Place pads under the jacks, if necessary, at this time. A lit yellow “LEVEL” light indicates that the end, side, or corner is low. Push an “EXTEND” (up arrow) button to extend the jack

pairs according to the lit yellow lights. Always level the vehicle from side to side before leveling the vehicle from front to rear. Two yellow “LEVEL” lights can be on at one time. Extend the jack pair accordingly until all yellow lights are out. If the ground is too uneven, the jacks may not have enough strokes to level the vehicle. The vehicle may have to be moved. After the vehicle is level, the jacks not used for leveling may be extended until they touch the ground. This provides additional stability against wind and activity in the vehicle. Do this by pushing the front and/or rear “EXTEND” buttons as needed to extend any remaining jacks. Do not use the right or left “EXTEND” button. Push the “OFF” button on the touch panel. Turn the ignition switch off.

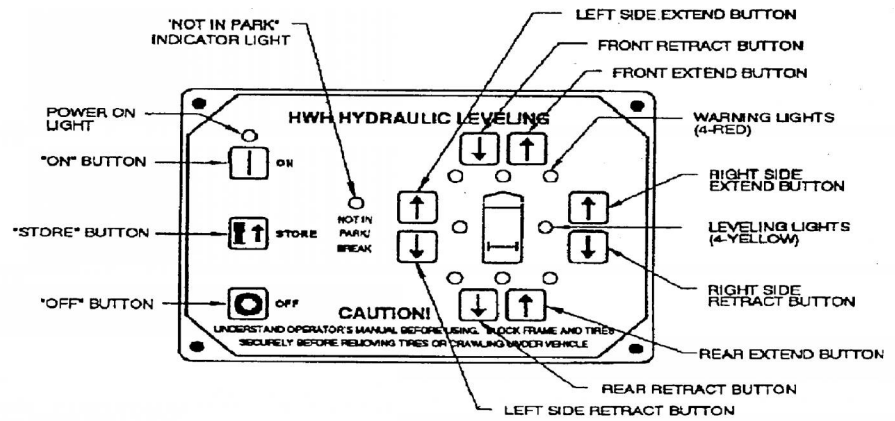

## IMPORTANT

The leveling system should be cycled once a month or whenever the vehicle is used to keep the system in operating condition.

To retract the jacks, turn the ignition switch “ON” but do NOT start the engine. Press the “ON” button on the control panel one time. The “ON” indicator light will glow steady. Press the “STORE” button. As each jack retracts, its red “WARNING” light will go out. The vehicle can be moved as soon as the red “WARNING” lights are out, provided the jacks are in the STORE/TRAVEL position. The system will automatically shut down approximately two minutes after the four individual red “WARNING” lights are out. Refer to the HWH Owner’s Manual for more instructions. The engine can be started once the jacks have fully retracted.

## Electric Steps

This unit may be equipped with electric double entrance door steps. If so, the switch to operate these steps may be located in an overhead cabinet above the entrance door. When the power switch for the steps is in the on position, simply open the door and the steps will open. Detailed operation for the electrical entrance door steps is as follows:



1. Turn the step power switch on.
2. Close the door. The step should retract and lock into the up position.
3. Open the door. The step should extend and lock into the down position.
4. Turn the step power switch off. The step should remain in the extended position when the door is closed. Turning off the power with the step retracted will hold the step in a retracted position as well.
5. With the step extended, turn the step power switch off and close the entrance door. Turn the vehicle ignition on. The ignition override system will go into effect, and the step will automatically retract.

### CAUTION

**If the vehicle is driven with the step in the extended position, there is the possibility of causing major damage to both the step and the vehicle.**

6. Turn the vehicle ignition off and open the door. The step will extend and lock in the down position.

### CAUTION

**If the door is opened and closed without allowing the step to fully extend and lock in the 'DOWN' position, the step will retract and lock in the 'UP' position. When the door is reopened, the step will not extend. The power switch must be turned on for the step to extend. This feature is only operative the first time that door is opened after the vehicle ignition is turned off. When the ignition is on, the step will always activate with the door movement, regardless of the step power switch position.**

## Mirrors

This vehicle is equipped with convex remote controlled defrosting exterior rear view mirrors. Always adjust the mirrors for maximum rear visibility prior to driving. Make sure the seat is positioned for proper vehicle control.

These mirrors are adjusted by using the multiple directional switches located on the driver's door. Select the mirror to be adjusted by pointing the arrow in the direction of that mirror. Move the control in the direction of movement desired to obtain the best view. The adjustment control moves the top half of both mirrors. The bottom half of the mirror is convex and is adjusted manually. These mirrors also contain heating elements to defog or de-ice the mirror glass during cold weather operation. The ON/OFF switch for this feature is located by the adjustment control. The convex exterior chrome mirrors with remote control and defrost are optional on this unit.

### IMPORTANT

**Objects viewed in convex mirrors appear smaller and farther away than they actually are.**

## Windows

The windows installed in this unit may be the radius torque style double pane tinted safety glass. These windows are also referred to as jalousie windows. They open with the simple turn of a crank. A power window is available on the driver's side as an option.

Sun shades may be standard on the driver and passenger side windows.

In the bedroom of the unit, one window will be marked "EXIT." This window is an emergency escape, or egress, window. To open in case of an emergency, lift the red handles at the bottom of the window and push out.

## Vents

A 12 volt vent may be installed in the kitchen. This vent is equipped with a rain sensor on the roof hood. Anytime the vent is open and it senses rain, it will automatically close. The vent is controlled by the wall thermostat. Once powered "ON" and the desired temperature is selected, the vent will run until the temperature is reached. When the temperature is reached, the vent will automatically shut off.

Do not leave the fan in active mode while the unit is in storage or unattended for long periods of time. High winds or other unusual conditions or obstructions may prevent the vent from closing resulting in leakage, which could cause serious damage.

The vent installed in the bathroom is also powered by 12 volt electricity. This vent is controlled by the ON/OFF switch located on the wall. A vent similar to the one installed in the kitchen is optional.

In the bath area a skylight may also be installed. If installed, this is located above the tub/shower.

## Doors

The front entrance door is a radius door equipped with a dead bolt lock for added security and a power flush step well cover. When the door is opened fully, the door hinge will automatically hold the door open. To close the door from the open position, either the inside or outside handle must be released for the door to move. For your safety, a lighted, acrylic assist handle has been installed at the entrance door of the coach.

## AWNINGS



### IMPORTANT

**It is important prior to extending your main awnings that you inspect the areas beside and around your unit where the awning will extend to insure proper clearance.**

## Side Awning

A power side patio awning is standard on your Essex. Extension and retraction is controlled by a switch located adjacent to the entry door, either on the wall or in a side overhead cabinet. To operate, follow these instructions:

### Extending and Retracting

Turn the power "ON" to the awning. Press the "Extend" button on the awning switch panel and hold it until the awning has fully extended. To retract the awning, press the "Retract" button on the panel. Be sure to allow the awning to fully extend or retract when operating it. The mechanism is designed for best support at full extension, and fastens securely in place for travel at full retraction.

## Manual Retraction

In the event that electricity is not available in your unit, the power awning can be retracted manually. On top of the awning on the right hand side (when facing the coach), there is a “Manual Override” that you can employ to retract the awning (see illustration).



### IMPORTANT

**If you have a wind sensor mounted in this location, you will need to remove the Phillips head screw attaching the wind sensor, and set the wind sensor aside.**

1. Remove the Phillips head screw that is screwed into the well nut that is assisting in holding on the end cap.
2. Grasp rubber well nut that the Phillips head screw is screwed into. Pull the well nut out of the hole.
3. Take the provided 7mm Allen wrench and put it into a 3/8” battery operated drill.
4. Place the Allen wrench down in the hole where the well nut was removed. Insert the Allen wrench into the Allen Head screw that is down inside the case (Note: You will have to do this by feel as you cannot see the Allen Head screw once the wrench is inserted into the hole).
5. To close the awning, operate the drill in the “forward” direction. To open the awning, operate it in the reverse direction.

## “Oasis” Entry Door Awning

The “Oasis” entry door awning is a power operated awning. To extend the awning, press the “Extend” button on the switch plate. To retract it, press the “Retract” button. Please note that both buttons must be held down as the awning travels in or out. It will not extend or retract automatically.

## Window Awnings (optional)

Your unit may be equipped with matching window awnings. They are operated as all the power awnings on your unit are. Use the appropriate switches to extend or retract the awnings as desired, and **always check for clearance** on the exterior of the unit to be certain nothing will interfere with their deployment.





# Chapter 7

## PLUMBING & BATH FEATURES

FRESH WATER SYSTEM .....	3
<b>Kitchen Sink</b> .....	3
<b>Bath Sink, Shower &amp; Accessories</b> .....	3
<b>Monitor Panel</b> .....	3
<b>Monitor Panel Calibration</b> .....	3
<b>Water Pump</b> .....	3
<b>City Water Hook-Up</b> .....	4
<b>Fresh Water Tank Fill</b> .....	4
<b>Sanitizing</b> .....	5
<b>Drink Dispenser with Water Filter (Optional)</b> .....	5
<b>Water Heater By-Pass System</b> .....	6
<b>Fresh Water Lines</b> .....	6
<b>Exterior Shower</b> .....	6
WASTE WATER SYSTEM .....	6
<b>General Information</b> .....	6
<b>Toilet</b> .....	6
<b>P-Traps</b> .....	7
<b>Black Water Holding Tank</b> .....	7
<b>Gray Water Holding Tank</b> .....	7
<b>Waste Water Disposal</b> .....	7
<b>Camping with Sewer Hook-Up</b> .....	8
<b>No Fuss Flush</b> .....	8



## FRESH WATER SYSTEM

### Kitchen Sink

The kitchen sink installed in your unit may be an acrylic, double-bowl sink equipped with two sink covers to provide additional counter space when the sink is not in use. Cleaning care consists of washing with mild detergents and a soft cloth. Avoid using “S.O.S.” type cleaning pads because they may scratch the surface. The faucet in the kitchen may be a single-handle faucet with a pullout spout.

### Bath Sink, Shower & Accessories

The sink in the bathroom may be a porcelain sink. Use care when cleaning to prevent from scratching the surface. The bathroom accessories include two towel bars and a tissue holder. The faucet in the bathroom consists of a metal body with a brass finish. The shower installed is a combination fiberglass tub/shower with a glass shower door. The white tub faucet with shower head, hose and bracket coordinate with the sink faucet. An optional assist handle may be installed in the tub/shower.

### Monitor Panel

The monitor panel allows you to check the approximate levels in the fresh, gray, and black water holding tanks, as well as the battery condition. The monitor panel is generally located above or near the entrance door. Simply press the button of the item to check its status. The empty indicator light will always light when the button is pressed. If the tank is full, all of the lights will be on. Lights are sequential and indicate the level in approximately 1/4 tank increments. For example: If the tank selected is approximately 1/2-full, then the indicator lights E, 1/4, and 1/2 will be lit. On the right hand side of the monitor panel is the water pump switch. This switch controls the power going to the water pump, turning it either on or off.

### Monitor Panel Calibration

The monitor panel comes to you factory calibrated for accuracy and should not need to be adjusted. In the event that the system does not read accurately, then re-calibration may be necessary. The procedure for re-calibration is simple: First, fill the tank to be re-calibrated. Second, using the adjustment tool enclosed in the Owner’s Information Package (or any small flat-bladed screw driver), simultaneously push the button for that tank and rotate the adjustment screw located above the button and behind the face plate counter-clockwise until some of the lights turn off in sequence. Then slowly rotate the adjustment screw clockwise until the full light is completely on. Repeat this procedure as necessary for the remaining tanks. The system is now calibrated properly.

### Water Pump

The water pump is self-priming and totally automatic, operating on demand whenever water is required. The water pump is used to pressurize the fresh water system when the unit is not connected to city water. The switches to this pump may be located in the bathroom above the entrance door and in the water works compartment. To start the pump follows these instructions:

1. Fill or partially fill the fresh water supply tank.
2. Open the kitchen and bathroom faucets.
3. Turn the water pump switch on and allow the water to fill the water line and the hot water heater.
4. Close each faucet after it delivers a steady stream of water (close the cold water first). Leave the hot water faucets on until they also deliver a steady stream of water. This will ensure that the water heater is filled with water.
5. The water pump should stop running once all faucets are closed.

6. The pump is now ready for automatic operation. The pump will run when a faucet is opened and stop when a faucet is closed.
7. Never allow the pump to run for long periods of time without water in the supply tank. Pump damage or blown fuses may result.

If water doesn't flow when a faucet is turned on while using the demand system, use the following trouble shooting chart:

SITUATION	SOLUTION
Pump running – no water	<ol style="list-style-type: none"> <li>1. Fill tank.</li> <li>2. Clear the water line to the pump.</li> </ol>
Pump doesn't run	<ol style="list-style-type: none"> <li>1. Check the pump switch.</li> <li>2. Check the 12 volt fuses.</li> <li>3. Check the electrical connections.</li> <li>4. Check the battery.</li> </ol>

All of the water should be drained from the fresh water system when the unit is not in use for more than one week. For more detailed information regarding the water pump, refer to the water pump manufacturer's brochure in your Owner's Information Package.

### City Water Hook-Up

When connecting your unit to city water, be certain to use a water hose manufactured and labeled for potable water. This will ensure that the hose will not alter the taste of the water. To hook the city water supply to the unit, connect one end of the hose to the city water supply. This will usually be a faucet or valve similar to your garden hose valve at home. Turn the city water supply on for a few seconds in order to clear the line. Once the hose has been flushed, turn the supply off. Connect the other end of the hose to the city water connections. Turn on the water supply and open all of the faucets to clear the air from the lines in the unit. Once air pockets have been purged from the water lines and water flows freely, close all of the faucets. The city water supply is under pressure; therefore the water pump is not necessary when connected to city water. Once the city water fill valve is opened, water is supplied to the fresh water system including the hot water heater, faucets, and stool. To disconnect from the city water supply, close the valve and remove the hose from the city water supply. Disconnect the hose from the city water connection and store the hose in the water compartment.

### Fresh Water Tank Fill

The fresh water tank is filled from the city water hook-up. The valve located in the service compartment near the water hook-up determines whether the city water is going through the water system or into the fresh water tank. An additional way to fill the fresh water tank is with the winterizing intake hose placed in a bucket of water (See Chapter 9). Since there is not an automatic shut-off for the fresh water tank fill, check the level from the monitor panel while filling the unit. The excess water will be vented from an overflow vent pipe onto the ground when the tank capacity has been reached. This pipe is installed in the fresh water tank to prevent tank rupture from overfilling. All of the water should be drained from the fresh water system when the unit is not in use for more than one week. Whenever possible, drain the fresh water tank before traveling. Water in the tank will reduce the carrying capacity of the unit.

## Sanitizing

To assure complete disinfecting of your fresh water system, it is recommended that the following procedure be followed on a new system, on one that has not been used for a length of time, or one that may have become contaminated. This procedure is also recommended before long periods of storage, such as over the winter months:

1. Drain the fresh water tank by opening the drain valves. There is one valve per water tank. All of the faucets should be in the closed or off position.
2. Prepare a chlorine solution using one gallon of water and 1/4 cup of chlorine bleach (5% sodium hypochlorite solution). Prepare enough of the chlorine solution to administer one gallon of solution for every 15 gallons of tank capacity. For sanitizing this unit, prepare 4-1/2 gallons of the chlorine solution. This mixture puts a 50 PPM (parts per million) residual chlorine concentration in the water system that will act as a quick kill dosage for harmful bacteria, viruses and slime forming organisms. Concentrations higher than 50 PPM may damage the water lines and/or tank.
3. Once the fresh water tank is empty, close the drain valves on the water tank.
4. Pump the chlorine solution into the tank. This is done by placing the winterizing hose into the chlorine solution. Close the valve from the fresh water tank to the pump and open the valve from the solution to the pump. Turn the tank fill valve from city water to tank fill. Turn on the water pump until all of the solution is pumped into the fresh water tank.
5. Turn off the water pump. Close the valve to the solution. Open the valve from the tank to the water pump. Fill the water tank with the city water tank fill (or by using the same method as was used to put the sanitizing solution into the tank). Remove the water filter (from the drink dispenser faucet, if installed) and install the by-pass pipe to allow the sanitizing solution access to the faucet. Open each faucet in turn including the kitchen faucet, bath faucet, inside and outside shower, turning on both the hot and cold, and flushing the stool until all of the air has been purged from the pipes and the water runs freely. The entire system will then be filled with the sanitizing solution.
6. Allow the 50 PPM disinfecting solution to stand in the system at least four hours.
7. Drain the system and flush with fresh water. The water system needs to be flushed with clean water repeatedly, if necessary, until there is no chlorine taste or smell left in the system. To remove any excessive chlorine taste or odor that might remain, prepare a solution of one quart vinegar to five gallons of water. Allow this solution to agitate in the tank for several days by vehicle motion. Drain the solution and refill the tank with clean water.

## Drink Dispenser with Water Filter (Optional)

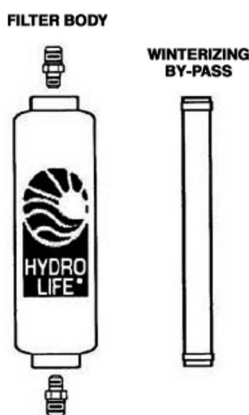

If this unit is equipped with a water filter, it must be removed before disinfecting the fresh water system. First remove the water filter, and then install the by-pass pipe to allow the sanitizing solution access to the drink dispenser faucet. The water filter is located under the kitchen sink. The filter will remove chlorine, dirt, and other matter. It will also eliminate most phenol (or similar) odors and tastes while delivering sparkling, taste free water for drinking and cooking. The filter is connected only to the cold water line that is attached to the drink faucet. The filter is not guaranteed to remove the tastes and odors of iron and sulfur. To remove these tastes you will need to chlorinate the water. Replacement filters are available that will filter iron and sulfur. Ask your dealer or RV supply center about acquiring an iron and sulfur filter. If you are traveling in an area where the water has a high iron and sulfur content, then add 1 tablespoon of chlorine bleach to every 10 gallons of water in your tank. This will precipitate the iron

or sulfur so that the filter can remove it. If you are at a site where the unit is hooked up to city water, you will not

be able to chlorinate the system because the water flows straight to your faucets and not through the fresh water tank. Filters should be changed every 6-12 months depending on the quality and quantity of water that is used in your unit.

### **Water Heater By-Pass System**

The water heater by-pass valve is located in an outside compartment near the water heater. By closing the water heater supply valve and opening the by-pass valve you can divert water away from the water heater. This is done when winterizing your unit. Using the by-pass will keep antifreeze out of the water heater when winterizing the system. Draining the water heater during winterizing is a **MUST**.

### **Fresh Water Lines**

Vibration and flexing during traveling can cause pipes and fittings to work loose. Check all of the plumbing connections for leaks on a yearly basis. If the water pump runs when all faucets are turned off, check for a leak. Be sure the drain valves are closed. Connections at the kitchen and bathroom faucets normally seal with hand tightening and a half turn with a wrench. If a fitting leak persists, disconnect it completely and check for mineral deposits or foreign material on the sealing surfaces. Clean the surfaces thoroughly and reinstall the fitting. Take the coach to an authorized service center for repairs if the system continues to leak. Follow the winterizing instructions given in Chapter 9 to reduce the risk of leaks caused by cracks from freezing pipes. Freezing damage can be extensive and expensive.

### **Exterior Shower**

A feature on your coach may be the exterior shower. If installed, the exterior shower would be located on the off door-side of the coach. The exterior shower feature allows you to do such things as rinse off sand or grass, muddy shoes, or bathe your pet outside of your unit. The faucet operates just as it would in your kitchen or bathroom.

## **WASTE WATER SYSTEM**

### **General Information**

The waste drainage system was designed to provide adequate and safe storage and/or disposal of waste materials. All of the materials used in the making of this system are tested by a nationally recognized testing laboratory. The drainage system uses plastic piping and fittings connected to the sinks, toilet, and holding tanks. This provides for their drainage to an outside termination. The unit should be reasonably level for best operation of the system. There are two separate waste systems. The gray water system is for waste water from the sinks and shower. The black water system is generally for sewage waste from the stool. Each tank has its own control valve, and both tanks drain through the sewer drain hose.

### **Toilet**

The standard toilet in your unit is a china stool. The toilet operates with water from either the fresh water tank with the water pump on or the city water supply. Before using the stool, add water to the bottom of the tank. Refer to the “BLACK WATER TANK” instructions in this chapter. The stool flushes waste directly into the black water holding tank. The stool uses high velocity water injection to produce a swirl effect in the bowl. The greatest problem that causes stool solids to build up in the holding tank is lack of liquids. When using your stool, it is wise to fill the stool 3/4 full of water. This will help to wash the solids away from directly below the stool and to ensure complete dumping of the holding tank. To add water to the stool bowl, lift or raise the flush lever until the desired water level is reached. To flush the stool, push down on the lever until the water swirls. A small amount of water should remain in the bowl.

The stool should be cleaned regularly for maximum sanitation and operational efficiency. Clean the toilet bowl with a mild bathroom cleaner. Do not use chlorine or caustic chemicals, such as laundry bleach or drain opening types, as they will damage the seals in the toilet and dump valves.

Refer to the toilet manufacturer's Owner's Manual in your Owner's Information Package for complete instructions and a troubleshooting guide.

## P-Traps

Each of the sink drains, the shower drain, and the washing machine drain (if equipped) has a water trap (P-Trap) to prevent holding tank odors from entering the coach. These traps must have water in them in order to trap the odors. While traveling, the water may splash out of the sink and shower drains. While stored, the water may evaporate allowing an odor to enter the coach. If this occurs, run water from the faucet into the drain, allowing water to fill the trap.

## Black Water Holding Tank

The black water, or sewage, holding tank is located directly beneath the toilet. Before using the stool, you will need to treat the tank with water that is mixed with an odor controlling chemical. These chemicals are readily available at any RV supply store. Be careful not to spill the chemical on your hands, clothing, or the carpet because it may cause a permanent stain. Pull the toilet levers forward to allow the chemical to mix with the toilet water. Continue pulling the toilet levers until at least one inch of solution is directly under the toilet. Release the levers, and the waste tank is ready for use.

### CAUTION

**Use only approved RV odor controlling chemicals in the holding tanks. Products containing ammonia and petroleum will damage the ABS plastic holding tanks and seals.**

## Gray Water Holding Tank

The gray water holding tank is located in the underbelly of the unit. It is primarily used for the drainage from the kitchen and bath sinks and the shower.

## Waste Water Disposal

Both of the holding tanks terminate in a valve arrangement that permits draining each tank separately or together. It is recommended to drain the black water tank before the gray water tank. This will allow the water from the gray tank to wash the black water residue from the drain lines and hose. The valves that open to release the water are called gate valves. The blade that closed the opening in the sewer drain pipes is connected to the T-handle to release the contents of the tank(s) when pulled. The sewer line must be securely capped during self-containment use to prevent leakage of waste material onto the ground or pavement. Do not pull the holding tank gate valve open when the protective cap is installed on the pipe. Always drain the tank into an acceptable sewer inlet or dump station.

### WARNING

**Holding tanks are an enclosed sewer system and must be drained into an approved dump station. Both black and gray water holding tanks must be drained and rinsed thoroughly on a regular basis in order to prevent the accumulation of harmful or toxic materials. Whenever possible, drain the holding tanks prior to traveling. The carrying capacity of your unit will be reduced if water is left in the black or gray tanks.**



The holding tanks should only be drained when they are at least 3/4 full. Doing this will provide sufficient water to allow the complete flushing of waste materials in the drain lines and hose. If the tanks are not 3/4 full, add enough water to allow for sufficient flushing. To empty the waste water tanks, connect the adapter to the drain hose. Use the adapter supplied with your unit. If the adapter is lost or broken, one can be purchased from any RV supply store. Once you have placed the adapter on the drain hose, it can remain there for the life of the hose. One end of the hose threads up through the hole in the bottom of the service compartment, and the other end of the hose feeds into the sewer at the dump station. Unscrew the cap off the drain. Connect the hose with the adapter in place to the drain fitting. Open the gate valve all the way by pulling on the T-handle. The tank will start to drain as soon as the T-handle is pulled. After you have drained the black water tank, immediately drain the gray water tank. Doing this helps to flush the black water from the sewage hose. When both of the tanks are empty, flush them with a fresh water rinse before you close the valves. The gray tanks are easily flushed by pouring a couple of gallons of water into a sink drain. The drain outlet is engineered for quick release of the drain hose adapter. Always close the gate valves and secure the end cap to prevent leakage while in transit. After draining the black water tank, it is recommended to add a holding tank deodorant (such as Thetford Aqua-Kem) to help control the odor and break down the solids. Follow the instructions given on the holding tank deodorant package. When using dump stations for draining the holding tanks, keep other travelers in mind. Practice good housekeeping. Leave the dump stations in good order. Above all, do not pollute.

### Camping with Sewer Hook-Up

When camping at parks with sewer hook-up, it is important to keep the black water holding tank gate valve closed at all times, except when dumping. The gray tank can be kept open while hooked to a sewer connection but again; the black water tank must be kept closed. This is done so that an ample supply of liquid remains in the tank to provide a smooth flow through the gate and drain valve when dumping. Sufficient liquid in the tank causes a swirling action that should take any accumulated solid wastes with it. Accumulation of solid wastes in the black water tank can be avoided by keeping the gate valve closed when connected to the sewer hook-up. If the valve is left open, solid wastes may accumulate in the tank. This may eventually result in costly repairs.

#### CAUTION

**The gray tank valve must be in the open position when operating the optional washing machine.**

### No Fuss Flush

This unit may be equipped with a flushing system for the holding tanks. When draining your sewer tank, attach a water hose to the sewer spray hookup. After the tank is drained, **leave the gate valve open** and open the water valve to allow water to spray inside the sewage tank. This will clean the inside of the tank of any debris that may be left inside the tank. After this is done, disconnect the freshwater hose and close the gate valve. When unsure if any solids are still left inside the tank, fill the sewage tank with approximately ten gallons of water through the stool. As you travel the agitation of the water should help liquefy any solids left in the tank. You can dump the sewage tank again at your next destination.

#### CAUTION

**Do not use the same hose for the No Fuss Flush that is used for filling the fresh water tank. Also, the gate valve to the sewage tank MUST be in the OPEN POSITION while rinsing with the No Fuss Flush system.**

# Chapter 8

## SLIDE OUT FEATURES

SLIDE OUT FEATURES .....	3
<b>General Instructions</b> .....	<b>3</b>
<b>Operating the Slide Out Room</b> .....	<b>4</b>
 MANUAL EXTENSION AND RETRACTION .....	 4
<b>Operating Precautions</b> .....	<b>5</b>



## SLIDE OUT FEATURES

### WARNING

**Read the following slide out room instructions before activating the switch.**

Do not allow children to operate the slide out.

Do not allow any person to place their arms, legs, body or head between any pinch point of the lock arms, slide out fascia, interior walls, exterior walls, objects, or floor as serious injury or death could result.

Any adjustments, or repairs, must be made only by “NEWMAR” qualified personnel.

Always check the interior and exterior of the coach for objects, or persons, that are in the path of the slide out when extending or retracting the room.

Always check the roof to be sure any objects, or debris, are removed before retracting the room.

### CAUTION

It is recommended that the leveling jacks be extended and the unit level before operating the slide out. Note: This slide out can be operated without utilizing the leveling system, but is recommended to have the unit as level as possible.

Your unit is equipped with at least one power slide out room. It is important that you read and understand **ALL** directions, both in this Owners Guide, and on **ALL** the labels affixed inside your unit **PRIOR** to operating your slide out room(s).

Depending on the type of locking mechanism (manual or power) used on your slide out rooms, your unit will contain labels with operating and safety information. Regardless of lock type, there are a number of precautions that **MUST** be observed every time the rooms will either be extended or retracted. For your personal safety, and to prevent potential damage to the slide out mechanism and room, it is paramount that these directions be followed completely. Slide out operation has changed for all 2006 RV's, and it is important that you understand the operation procedure completely and observe all safety precautions to insure safe, proper operation.

All Slide Out labels contain the following warning:

### **WARNING**

**Do not allow children to operate the slide out.**

**Do not allow any person to place their arms, legs, body or head between any pinch point of the lock arms, slide out fascia, interior walls, exterior walls, objects, or floor as serious injury or death could result.**

**Any adjustments, or repairs, must be made only by “NEWMAR” qualified personnel.**

**Always check the interior and exterior of the coach for objects, or persons, that are in the path of the slide out when extending or retracting the room.**

**Always check the roof to be sure any objects, or debris, are removed before retracting the room.**

## General Instructions

### IMPORTANT

The slide out room should be inspected for alignment every six (6) months. If alignment is necessary, have the room adjusted.

## IMPORTANT

The slide out room can be stopped at any time by releasing the slide out switch. If the slide out room stops before reaching the full “OUT” or “IN” position, the slide out controller may need adjustment. To adjust the slide out controller, turn the adjustment screw clockwise to increase the power and counter-clockwise to decrease the power. Move the adjustment screw in small increments. Try moving the slide out room again. Use caution. There is a potential for component or structural damage if the screw is adjusted too high. This screw does not adjust the slide out room speed. It sets the amount of power required to move the room against the mechanical stops.

### Operating the Slide Out Room (w/Power Lock Arms)

Your unit may be equipped with the option of Power Locking Arms for the slide out rooms. Designed specifically for this application, these mechanisms automatically “lock” the slide out rooms to the sidewalls of the RV when the room is fully retracted, securing the room in place and providing a positive seal. The operation of the locking mechanism is totally automatic, and begins when you press the button to extend or retract the slide out room.

To extend the room, press and hold the slide out button. The voice modulator will activate and say, “Your lock arms are unlocking. Please be certain all seats, chairs, and other obstacles clear of the slide out area”. The power lock arms will retract into their housings, and the room will begin to extend approximately 10 seconds after the voice begins. It will continue to run until it reaches the end of its travel, or until you release the slide out switch.

To retract the room, press the slide out button as described above, holding it for the duration of room travel. The room will retract, and at the end of its travel the slide out motor will stop, and the Power Locking Arms will deploy, securing the room to the sidewall of the unit. Please note that you must hold the slide out button down during this entire cycle.

The power locks require a minimum of 9 volts DC to operate. In the event of a loss of power, or if the voltage dips below the minimum requirements, the locks will not extend or retract automatically. For proper operation of the room and locks battery voltage must be maintained above the minimum requirements. Also please note that there is a safety “lock out” system incorporated in the slide out electronics that prevents the room from operating when the ignition key is “on”. The automatic locking arms require no maintenance, and should be serviced as necessary only by a qualified technician.

### MANUAL EXTENSION AND RETRACTION

The slide out room may be manually retracted. Before attempting to manually extend or retract a slide out room please contact your servicing dealer or call Newmar Customer Support at 1-800-731-8300.

## IMPORTANT

The TRANS-TORQUE bushing must be re-tightened to re-couple the slide out gear motor before moving the coach. This will hold the slide out room in place. The correct torque on the 1-1/2" TRANS-TORQUE bushing is 110 foot pounds maximum. The correct torque on the 1-1/2" TRANS-TORQUE bushing of the K-900 motor (center shaft motor) is 125 foot pounds maximum. Slide outs with either the center or end mounted motors can be moved by pushing the room the full length of its travel in either direction. This method will require the assistance of at least two people.

## Operating Precautions

### CAUTION

It is recommended that the leveling jacks be extended and the unit level before operating the slide out. Note: This slide out can be operated without utilizing the leveling system, but is recommended to have the unit as level as possible.

### WARNING

Before extending the slide out, make certain that there is a minimum of five (5) feet of clear space on the slide out side of the unit. Prior to extending the room, be sure to unlock the slide out locking arms. Make sure there are no obstructions either inside or outside the unit that may interfere with the slide out extension. Tree branches, bushes or telephone poles can cause extensive damage to the exterior of the unit.

### IMPORTANT

It is important to clean the slide out rollers under the floor regularly as dirt may adhere to the rubber coating on these rollers and cause damage to hard surface flooring. Such damage is not covered under warranty. These rollers may leave indentations in carpeting, linoleum and other flooring. This condition is normal and does not warrant flooring replacement.



Chapter 9

ROUTINE MAINTENANCE

EXTERIOR CARE..... 3  
    **Washing**..... 3  
    **Waxing**..... 3  
    **Seals** ..... 3  
    **Striping & Decals** ..... 4  
    **Simulator Care** ..... 4  
    **Rubber Roof Care & Maintenance** ..... 5  
    **Battery Inspection & Care** ..... 6

INTERIOR CARE ..... 6  
    **Carpet** ..... 7  
    **Fabrics**..... 7  
    **Walls & Ceiling** ..... 7  
    **Dash**..... 7  
    **Woodwork** ..... 8  
    **Counter Tops** ..... 8  
    **Accessories**..... 8  
    **Detectors** ..... 8  
    **Condensation** ..... 8

ROUTINE MAINTENANCE ..... 9  
    **Monthly**..... 9  
    **Every Three (3) Months** ..... 9  
    **Every Six (6) Months**..... 10  
    **Annually** ..... 10  
    **Cold Weather Use** ..... 10  
    **Head Lamps** ..... 10





## EXTERIOR CARE



### IMPORTANT

Damage caused by improper or unapplied maintenance is not covered by your Newmar Limited Warranty.

### Washing

The exterior of your new recreational vehicle is made of pre-finished aluminum and fiberglass. Frequent washings and thorough cleanings are required to prevent damage to the vehicle finish after exposure due to damaging salts, calcium chloride, road tar, tree sap, insects and other foreign material. Damage caused by exposure to these items is not covered by your warranty agreement. Never wash the vehicle in direct sunlight, while the vehicle is hot or with hot water. Buildup of mud and dirt under the body can cause damaging rust on steel parts. Corrosive materials, such as those used for ice and snow removal and dust control, also accumulate on the underside of the vehicle. These materials should be removed by flushing the underbelly regularly with water, especially areas where mud and other foreign materials collect. The chance of corrosion can be minimized by frequent washings of the vehicle. When washing the vehicle, make certain that the undercarriage and the wheel wells are cleaned, as well as the exterior of the coach. Do not use strong soaps or detergents for washing the vehicle. Always use a mild soap in warm water, a commercially prepared product for automotive finishes or your local car wash. Be careful when using a pressure-type washer to avoid loosening any exterior decals or sealants, etc. After washing, carefully inspect the caulking around window frames and vents and any other joints that may have separated. If re-caulking is necessary, it is relatively simple, and it is considered routine maintenance which is the responsibility of the owner.



### IMPORTANT

Never use a strong solvent, such as lacquer thinner or harsh abrasives, on any of the exterior painted surfaces.

### Waxing

The exterior finish will require a routine waxing. When water will not bead and roll off a freshly washed vehicle, a new coat of wax is needed. Wax not only improves the appearance of the vehicle, but it also protects the finish against oxidation and corrosive materials. The recommended type of wax is one that is compatible with painted or gel-coated fiberglass finishes, and contains a UV (ultra-violet) inhibitor. Buffing with a polishing compound will improve a dull or discolored finish.



### IMPORTANT

When using a polishing compound that does not contain a wax preservative, reapplying a coat of hard wax after polishing is recommended.

### Seals

The seals around doors, windows, vents, slide out trim and external seams should be checked at least twice a year. In addition, the roof seams should be inspected twice a year for cracking or peeling. If deterioration is noted during a routine maintenance inspection, reseal the seams or seals with an approved sealant to prevent leaks. Your dealer can perform the resealing inspections and work for you. It is recommended that a Newmar Authorized Service Center perform these inspections, and reseal when necessary.

## Proper Sealants for Application

Plas-T-Cote.....	Metal or fiberglass roof.
Surebond #SB-140.....	Rubber laminated to metal roof and all skylights.
Carlisle #502-LSW .....	Rubber roof over wood base.
Self Leveling Sealant Silicone Sealant .....	To cover butyl and other sealants; not to be used as the main sealant.
Parbond.....	To seal across tops of windows, etc. on exterior where silicone is not used.

## Striping & Decals

The striping and decals on your vehicle require little maintenance. Treat these as you would any painted surface on your vehicle. Wash them with mild soap and warm water, or any retail car soap. Never wash the vehicle in direct sunlight, while the vehicle is hot or with hot water. Rinse thoroughly to prevent soap residue accumulation. Use caution with high pressure wash nozzles. Keep them at least 18 inches from the edge of the decals. High pressure water may cause the decals to loosen and peel. Test small sections of decals when using any type of cleaning solution.



### IMPORTANT

Do not use solvents such as acetone, MEK, toluene, etc. on the decals. Any solvent including alcohol may soften or smear colors. Do not use lacquer thinner or paint on decals. Do not overcoat the decals with clear paint. Do not allow gasoline or other fuels to drip or stay on the decals for any length of time. If this occurs, immediately flush the area with water.

## Simulator Care

The care and maintenance of your stainless steel wheel product is simple and requires no special material or products. All products are constructed of highly polished 304L stainless steel. Timely care and cleaning will keep them looking great for many years. We suggest the following care:

1. Clean your wheel cover/liner on a regular basis to keep road dirt from building up.
  - A. Rinse with clean water to remove loose dust and dirt.
  - B. Clean with a mild soap and water solution. (Any non-abrasive household detergent works fine.) Apply with cloth, sponge, or soft bristled brush. Use solution liberally to avoid surface scratching due to trapped dirt on the applicator.



### IMPORTANT

Do not use harsh detergents, acids, or abrasives which may scratch or dull the surface. The applicator cloth, sponge, or soft bristled brush should be non-metallic and non-abrasive

- C. Rinse thoroughly with clean water to remove excess soap and dirt.
- D. Repeat above steps as required.

- E. If stubborn stains persist, such as road tar, brake dust, oil, etc., use only a product compatible with stainless steel. An over-the-counter window cleaner (like Windex) will often remove foreign material. If a harsher cleaner is needed, we recommend “NEVR-DULL,” available at many general hardware or automotive stores.
2. Surface rust: From time to time, surface “spin out” rust may appear on the stainless steel. Normally the "spin out" rust comes from the wheel, lug nuts, locator pins, etc. In many cases, regular normal cleaning of your decorative wheel product, as indicated above, will remove any surface rust. If, however, a stubborn rust spot remains, utilize “NEVR-DULL” (a wadding polish), applying constant pressure to remove any surface blemish. You may have to repeat this process on hard to remove spots. After cleaning with “NEVR-DULL,” you may want to re-shine your wheel products using Windex or a similar product.
  3. Petroleum based tire conditioners: While the use of these products (Armor-All, Son-of-a-Gun, etc.) may improve the appearance of your tires, these types of products will form a film on your stainless steel wheel cover product. To remove, use a mild cleanser, like Windex, to restore the shine.

### IMPORTANT

Remember to periodically check the tightness of your wheel cover product.

## Rubber Roof Care & Maintenance

Proper care and maintenance of your recreational vehicle, including your rubber roof, is important for trouble-free performance. Normal maintenance is simple and easy, and does not require special materials. Keep the roof clean. Clean the roof at least four (4) times annually. For normal cleaning:

1. Use RC100 Decor Synthetic Roof & General Purpose cleaner or a mild laundry detergent.

### CAUTION

Do not use general purpose cleaners or conditioners containing petroleum solvents, harsh abrasives or citric-based cleaners. You may cause irreparable damage to your roof.

2. Rinse the complete roof with clean water to remove any loose dirt or debris.
3. Using a medium bristle brush, along with your selected cleaner mixed with water, scrub the entire roof. Rinse thoroughly with clean water to avoid residue build up on the roof or sidewalls of the vehicle.
4. For more difficult stains, you may use cleaning materials mentioned above in a more concentrated mixture. For stubborn stains, use of a cloth dampened with household bleach. Household bleach can be used (fully concentrated) and allowed to soak in stubborn stain areas, then scrubbed with a medium bristle brush or rag. Rinse thoroughly. Do not pour the bleach on the roof and allow it to run down the sides of the vehicle. Concentrated bleach may damage the graphics.

### WARNING

Use caution when working on top of your vehicle. The wet roof membrane may be extremely slippery.

## Battery Inspection & Care

### WARNING

Remove rings, metal watch bands, and other metal jewelry before working around batteries. Use caution when using metal tools. If a tool contacts a battery terminal or metal connected to it, a short circuit could occur which could cause personal injury, explosion or fire.

### CAUTION

Disconnect the 120 volt electrical power cord and the negative terminal from the coach batteries before working on the electrical system.

Remember that when batteries are not used for an extended period of time, they may lose their charge. Periodic charging of the batteries during storage of the unit will increase the life of the battery. Check the external condition of the battery periodically. Look for cracks in the cover and case. Check the vent plugs and replace them if they are cracked or broken. Keep the battery clean. Accumulations of acid film and dirt may permit current flow between the terminals, which could drain the battery.

To clean, wash the batteries with a diluted solution of baking soda and water to neutralize any acid present. Rinse thoroughly with clean water. Foaming around the terminals or on top of the battery is a sign that acid is being neutralized. Avoid getting the baking soda solution in the battery. Secure all vent caps. Dry the battery cables and terminals to prevent corrosion. Do not use grease on the bare metal inside the cable terminals. Grease can act as an insulator, and electricity will not flow through it. A plastic ignition spray will protect the terminals after they have been cleaned.

### WARNING

Do not allow the battery fluid to contact your skin, eyes, fabric, or painted surfaces. The fluid could cause serious personal injury or property damage. Wear eye protection when working with any battery.

The batteries should be removed and stored in a warm place when not using your motorhome for an extended period of time. Mark the cables, positive and negative, for easy identification. Batteries are not to be stored on concrete floors. The batteries require periodic charging during storage. If the motorhome is to be stored for a long period of time, it is recommended that all of the batteries inside the unit be removed from clocks, radios, smoke alarms, etc. This will prevent unnecessary drain and corrosion of the batteries. The coach batteries are 6 volt RV/Marine deep cycle batteries. This type of battery consumes water and must be filled periodically. Please be sure to check the battery water level on a regular basis. Consult the Owner's Manual supplied by the battery manufacturer.

## INTERIOR CARE

### WARNING

Urea-formaldehyde is used in the productions of particle board, hardwood plywood, and most paneling. Urea-formaldehyde resin may release formaldehyde vapors into the air, which may cause headaches, and in some people, eye, nose and throat irritation. Formaldehyde may intensify some allergies or upper respiratory problems like asthma. Providing proper ventilation as needed by operating the power roof vents and opening windows should reduce the risk of such problems.

## IMPORTANT

The fading of upholstery, carpet and other interior fabrics is generally caused by excessive sunlight. The drapes, blinds or shades should be kept closed when the vehicle is parked for an extended period of time to minimize the fading. Normal deterioration of appearance items due to wear and/or exposure is not covered by the Newmar Limited Warranty.

### Carpet

A weekly routine of vacuuming the carpet and fabrics throughout the vehicle is recommended. This will prevent an accumulation of dirt that can detract from the materials appearance and shorten its life. Remember to empty or replace vacuum bags before they become half full. In carpet areas that receive the most sunlight, close the curtains frequently to prevent fading. And act quickly when anything is spilled or dropped on the carpet.

Included in the Owner's Information Package is the carpet manufacturer's Carpet Care Guide. The Carpet Care Guide lists detailed information on cleaning soiled areas and removing stains from the carpet installed in the unit.

### Fabrics

The fabrics used in this motorhome for the bedspread, draperies, headboard and valances contain fire-retardant additives that may be damaged by use of improper cleaning products. Cleaning instructions for these items are DRY CLEAN ONLY. Water-based products are not recommended for cleaning the fabrics in your new unit. Most water-based household cleaning products are not formulated for use on these fabrics and may cause excessive shrinkage or fading. For best results, the fabrics in this unit should be cleaned by a professional carpet and upholstery cleaner.

Spills, spots or stains should be treated as soon as possible to avoid permanent damage. If a spill occurs, blot the fluid with a dry towel. Do not rub the spill. Rubbing may cause the liquid to "set" in the fabric. When attempting to clean a spot or stain, always start from the outside and work inward to avoid spreading it further. Some stains or soils are extremely difficult or impossible to be removed completely. These should receive immediate, professional attention. Spills, spots, stains or soils are the responsibility of the owner, and are not covered by the Newmar Limited Warranty.

## WARNING

When cleaning the upholstery and fabric in the unit, do not use lacquer thinner, nail polish remover, laundry soaps or bleach. Never use carbon tetrachloride or gasoline for cleaning purposes. These items may cause damage to the materials being cleaned, and most are highly flammable.

### Walls & Ceiling

The wall and ceiling coverings should be cleaned periodically to maintain a new appearance. Use a non-abrasive cleaner with a soft cloth on the walls. Do not use solvents of any kind. Solvents may damage the surface.

### Dash

In order to keep the dash in like-new condition, follow these guidelines:

Do—

- Dust and clean the dash with a soft, damp cloth, or chamois, wiping the surface gently.
- Use a mild detergent and lukewarm water.

- Dry the surface, after washing and rinsing, by blotting with a damp cloth or chamois.

#### Do Not—

- Use harsh chemicals that may damage the dash.
- Use cloths containing grit or abrasive particles or kitchen scouring compounds to clean or dust the dash.
- Subject the dash to hard, direct blows.
- Use boiling water, strong solvents or other materials listed below to clean the dash, as they will soften the plastic.

### Woodwork

The wood cabinetry should be cared for with furniture polish to sustain the natural beauty and luster of the wood. This will also keep your cabinetry looking new, and prevent the wood from drying. The simulated plank flooring should be protected from dents, scratches and nicks by installing protective pads on the bottom of chairs and tables. Use of area rugs and floor mats by the entrance door is recommended to trap dirt. To clean the flooring, begin by vacuuming the floor to remove loose dust and dirt. Then, damp mop the floor with one ounce of Wilsonart Flooring Cleaner diluted in one gallon of clean, warm water (or use a non-abrasive, soap-free cleaner). The mop should be damp, not dripping. Do not use soap-based cleaners, scouring powders, steel wool, abrasive cleaners, wax or polish on the floor. To remove stubborn spots like shoe polish, oil, tar, markers, scuffs, etc., use a household solvent, acetone or nail polish remover, then wipe with a damp cloth. To remove chocolate, grease, juice or wine, use warm water and a non-abrasive cleaner. To remove candle wax or chewing gum, carefully scrape off when the material has hardened. For further tips, please see the manufacturer's information sheet in your Owner's Information Package.

### Counter Tops

To properly care for the countertop in your new unit, always use a heat pad or trivet to protect the surface from hot objects that may mar or damage the surface. Also avoid cutting directly on the surface and avoid using harsh chemicals on the counter top. Wipe the counter top with a damp cloth to remove water spots. For most dirt and stains, wipe with a damp cloth and use soapy water or ammonia-based cleaners.

### Accessories

The brass light fixtures, bath accessories and faucets can be cleaned by wiping with a soft, damp cloth. Washing with warm water will remove dry water spots. Do not use cleaners that contain harsh or abrasive chemicals. Alcohol or similar solvents should never be used.

### Detectors

The CO and propane detectors (if equipped) are self-contained and DO NOT require any maintenance other than normal cleaning and dusting. The smoke detector installed in this coach is 9 volt battery operated. The battery needs to be tested periodically and replaced when necessary. When cleaning the case on any of the detectors, use a damp cloth or paper towel. Do not spray cleaners or wax directly into the case as it may cause false alarms.

### Condensation



#### IMPORTANT

Since surface condensation within the coach cannot be controlled by the manufacturer, damage caused by condensation is not covered by your Newmar Limited Warranty.

Damage may occur to your unit if excessive condensation exists. Accumulation of condensation on surfaces within your unit occurs when warm, moist air contacts a cool surface. It is most evident on the inside of windows. This problem can be controlled by:

1. Slightly opening a window or roof vent to allow the moisture to escape from the unit.
2. A small dehumidifier is also very effective in removing moisture from the air.
  - Condensation levels are highest during times when a person is cooking or taking a shower in the unit, but these are not the only times condensation is present.
  - Condensation can migrate through ceiling panels and saturate the fiberglass insulation in your ceiling cavity. This condition often causes the occupants to believe the recreational vehicle has a roof leak. Walls and ceiling panels may also become wet when the moisture accumulates on these surfaces.
  - Newmar Corporation does not recommend the use of any catalytic heaters.

## ROUTINE MAINTENANCE

### IMPORTANT

Always follow the chassis maintenance guidelines found in the chassis manufacturer Owner's Manual.

All routine maintenance is the responsibility of the owner and is not covered by the Newmar Limited Warranty. Use the maintenance record found in the Charts & Diagrams Booklet to record all performed maintenance as required. Please note that damage caused by improper or unapplied maintenance is not covered by the Newmar Limited Warranty.

Items supplied by other manufacturers may require specific individual maintenance not listed herein. Please refer to the manufacturers' suggested maintenance guidelines in the Owner's Information Package.

### IMPORTANT

Cosmetic adjustments and alignments must be performed within the first three (3) months from date of original purchase for warranty consideration. Thereafter, these items are considered routine maintenance.

## Monthly

- Check battery water level.

## Every Three (3) Months

- Clean range hood exhaust fan filter and blades.
- Check gas lines for leaks with soap solution or leak detector.
- Test smoke alarm, carbon monoxide detector and propane gas detector.
- Check operation of windows, latches and hinges.
- Clean the roof ducted air conditioner filter(s).
- Clean and inspect all door and window seals; reseal where necessary.
- Inspect and reseal around the tub and shower area where necessary.
- Lubricate the exterior door hinges and latches with a graphite (silicone) lubricant.
- Check, clean and tighten battery cables, and inspect batteries for proper fluid level.



## Every Six (6) Months

- Inspect the slide out for proper seal. If realignment is necessary, please contact an Authorized Newmar Service Center.
- Inspect the exterior rubber slide out seals and apply a UV inhibitor, such as 303 Protectant.
- Rotate tires as recommended by the tire manufacturer.
- Check all gas appliances for proper operation.
- Have the propane system inspected by a qualified technician.
- Lubricate the moveable parts on the entrance step.

## Annually

- Inspection of roof seams and joints should be performed by an Authorized Newmar Service Center. If resealing is necessary, it is the owner's responsibility and is not covered by the Newmar Limited Warranty.
- Sanitize the fresh water system.
- Wax and buff all gel-coat surfaces on the vehicle as described previously in this chapter.

## Cold Weather Use

Although great care has been taken to build a well-insulated unit, recreational vehicles are not intended for extended use in subfreezing weather without special precautions.

When the temperature drops below freezing, the furnace must be turned on to keep the unit warm. Continued use in cold weather will require the unit to be winterized.

## Head Lamps

Recreational Vehicle headlamp maintenance recommendations while your vehicle is parked for long periods:

1. Check headlamp regularly for condensed water drops (daily in high humidity areas).
2. If small drops of condensed water are noted, drive your RV with the headlamps "ON" or just turn "ON" the headlamps. This will evaporate the condensed water drops and will help in avoiding the accumulation of water. Depending on the size, shape and location of the lamp on the RV, the atmospheric conditions occurring, the amount of time required to clear the lamp may vary from 2 to 6 hours.

### NOTICE

If water is allowed to accumulate, some stain marks on the reflective surfaces may appear, damaging the surface.

The headlamp seals should not be directly sprayed with high pressure (home or industrial) wash systems..