



WHEN YOU KNOW THE DIFFERENCE™

2020

Bay Star

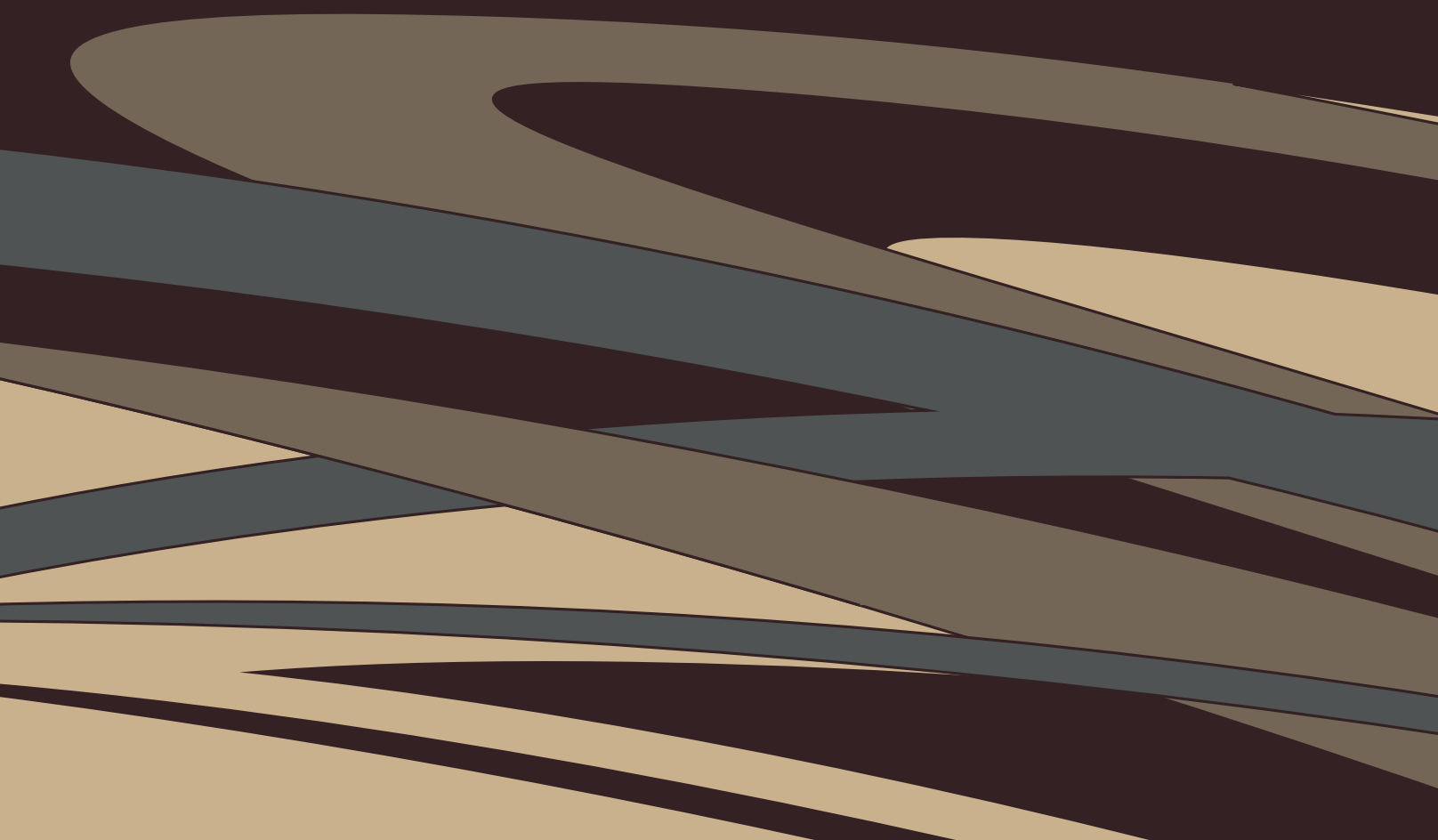

TABLE OF CONTENTS

NOTICE

This Owner's Guide is published and printed from Newmar's online knowledgebase. For the most up-to-date version of this content, and for more product-specific information, how-to articles, and troubleshooting information, please refer to Newgle. All of the information in Newgle is believed to be accurate at the time of publication. However, it may be necessary to make revisions, and Newmar reserves the right to make any such changes without notice or obligation.

INTRODUCTION

- 1 Newmar's Limited Warranty and Customer Support
- 2 About The Delivery Process
- 3 Introduction to Newgle
- 6 How Do I Find What I Need In Newgle?
- 10 Safety Notices in Newgle

SAFETY

- 11 Safety Resources and Compliance Requirements
- 11 Placards and Labels
- 12 Before Driving Away
- 12 Driving in Dangerous Conditions
- 12 Seat Belt Safety
- 14 Fire Safety
- 15 Carbon Monoxide Safety
- 16 Propane System Operation and Safety Overview
- 18 How to Open and Close the Emergency Exit Windows
- 19 How to Operate the Emergency Egress Exit Door and Ladder

APPLIANCES

- 21 Appliance Data Sheet and Safety Precautions
- 22 Cooktops and Ranges
- 24 Fireplaces
- 24 Microwaves and Convection Ovens
- 28 Refrigerators, Freezers and Ice Makers
- 34 Washers and Dryers

CHASSIS

- 39 Ford
- 39 Fuel Systems
- 39 Leveling Systems
- 43 Wheels and Tires

ELECTRICAL

- 45 12 Volt Electrical System
- 48 120 Volt Electrical System
- 52 Electrical Typical Amp Draw List
- 54 Batteries
- 60 Energy Management Systems
- 60 Fuse Panels
- 61 Generators
- 62 Inverters and Converters
- 67 Lighting
- 68 Receptacles and Accessory Chargers
- 69 Solar Power
- 70 Transfer Switches and Surge Protectors

ELECTRONICS

- 71 Camera and Video Monitoring Systems
- 72 Holding Tank Monitoring Systems
- 74 Navigation Systems
- 79 WiFi Systems

ENTERTAINMENT SYSTEMS

- 83 Antennas, Cable, and Satellite Systems
- 87 Blu-ray Players
- 89 Audio Systems
- 91 Remotes
- 94 Televisions

EXTERIOR

- 99 Awnings
- 102 Compartments
- 103 Doors, Handles and Chimes
- 103 Entrance Steps
- 104 Hitches and Towing Components
- 105 Ladders
- 105 Mirrors
- 106 Paint, Roof, and Siding
- 108 Windows and Windshields
- 111 Wiper Systems

HVAC

113	Air Conditioning and Heat, Dash
114	Air Conditioning and Heat, Roof
115	Fans and Ventilation
116	Furnaces
117	Thermostats

INTERIOR

119	Beds and Mattresses
121	Cabinetry and Woodwork
123	Ceiling and Walls
123	Countertops and Backsplashes
124	Fabrics and Materials
126	Flooring
126	Furniture
127	Interior Doors and Hardware
127	Interior Furnishings
127	Interior Steps and Step Covers
127	Shades and Window Coverings

PLUMBING

129	Water Compartment
130	Fresh Water System
134	Water Heaters
135	Water Pumps and Controllers
136	Faucets and Fixtures
137	Filters
138	Power Washers, Sprayers, and Exterior Showers
138	Waste Water System
138	Sinks, Tubs, and Showers
140	Toilets
141	Waste Water Holding Tanks
142	Waste Water Disposal
144	Holding Tank Rinse - No Fuss Flush

SLIDEOUTS

145	Extending and Retracting the Slideouts
146	Electric Slideout Operation
147	Electric Slideout Maintenance
148	How to Manually Retract an Electric Bedroom Slideout
150	How to Manually Retract an Electric Flat Floor Slideout
152	How to Manually Retract an Electric Full Wall Slideout
153	How to Manually Retract an Electric Kitchen Slideout
154	How to Manually Retract an Electric Wardrobe Slideout

CARE AND MAINTENANCE

157	How to Wash and Dry a Coach
158	Waxing and Polishing a Coach
159	How to Winterize a Coach
161	How to De-Winterize a Coach
162	How to Sanitize the Water System
163	Ultrafabrics Cleaning Guidelines for Flexsteel and Villa Furniture
164	How to Clean Exterior Chrome
164	How to Weigh a Coach
166	Routine Maintenance Schedule
167	Maintenance Record: Service
169	Maintenance Record: Fuel and Oil



INTRODUCTION

Newmar's Limited Warranty and Customer Support

Welcome to the exciting world of recreational vehicles and the growing Newmar family! Congratulations on your purchase of a Newmar product! Your coach proudly carries the Newmar torch, as a new generation of RV'ing begins. We share your excitement, and look forward to the years and miles of adventure the RV lifestyle offers you in your coach.

Whether camping at your favorite remote fishing hole or tailgating at the big game with your friends, Newmar is with you 24 hours a day, 7 days a week.



WHEN YOU KNOW THE DIFFERENCE.SM

The Newmar Legacy

Your new coach was built with care using today's technology and old world craftsmanship. At Newmar, we strive to build vehicles that are safe, dependable, and comfortable. Born on Christian principles, and from the desire to build not the most, but the best, the legacy associated with the name Newmar is one of family pride and quality. It is the culmination of decades of RV design and building experience.

We take humble pride in our history of innovation. We introduced the industry to the first slideout rooms, and continued our tradition of innovation with the first flush floor slideout in a motorized coach and the smooth, seamless fiberglass body. Your coach is at the forefront of current technology, built by the skilled hands and quality conscious eyes of craftsmen.

At Newmar, we recognize that a craftsman's final product is only as good as the materials they use, so we are selective about what we put into our coaches. We start with a foundation forged in the strength of steel and aluminum. We fill it with beautiful, durable hardwoods, and select name brand appliances and components, then build it on a chassis built to stand the test of time. Then we finish our units with an artist's gentle touch.

The Newmar Warranty

We stand behind our work with an exceptional warranty and dependable service, so you can travel with the kind of confidence that comes from knowing you're protected. What helps Newmar stand out against other manufacturers is our commitment to following our customers throughout the repair process to ensure any issues get taken care of the right way, right away.

LIMITED ONE-YEAR UNLIMITED MILE WARRANTY

Every Newmar motor coach is backed by our one-year, unlimited-mile expressed limited warranty.

LIMITED FIVE-YEAR STRUCTURAL WARRANTY

If any part of your Newmar recreational vehicle superstructure (which is the steel / aluminum structure of the sidewall, roof or frame) fails to perform properly within five (5) years from the date of purchase because of faulty workmanship or material supplied by Newmar, it will be repaired without charge for either parts or labor by Newmar. This structural warranty is available only to the original purchaser and is non-transferable.

CHASSIS AND COMPONENT MANUFACTURER WARRANTIES

Please read the Newmar Limited Warranty and all other component warranties that apply to the equipment installed on your unit. The limited warranties issued by the chassis and component manufacturers require periodic service and maintenance. The owner's failure to provide this service and/or maintenance may result in the loss of warranty coverage.

Be sure to file the appropriate registration card with the component manufacturer as described with the individual instruction booklets to activate the warranties on the components within your Newmar coach.

If you, for any reason, have a problem obtaining satisfactory and timely warranty service that may substantially impair the use, value, or safety of your Newmar coach, please call Newmar Customer Service toll free at **1-800-731-8300 (option #2)**.

Customer Support

Carefully read both the instructions in your Owner's Guide, as well as the booklets supplied by the chassis and component manufacturers for important operation, safety, and maintenance information. This Owner's Guide should be kept in your vehicle for quick reference. Take time to get acquainted with your unit and how it operates. Should you have any questions, consult your dealer or the Newmar customer support team. In addition to the assistance you receive from the customer support team, we are also excited to announce a new approach to customer service: Newgle.

Newgle is Newmar's dynamic, multi-faceted knowledge center and is created specifically for Newmar coach owners and certified technicians. Because content pertaining to your coach is constantly evolving and changing, the only way we can provide you with access to the most up-to-date and relevant information is by linking you directly to it!

Much of our information comes directly from the manufacturer of the items that are specific to your coach model and year, so we urge you to check out the site for any additional information that may not (currently) be included in your owner's guide. For more information, refer to the Introduction to Newgle article.

About The Delivery Process

This article provides a detailed list of the customer and dealer responsibilities during the delivery process.

Throughout the manufacturing process, your vehicle has been inspected by Newmar qualified technicians. However, our final inspection at the factory is not to be the last one. The pre-delivery inspection and systems check your dealer performs are the final inspections done to the unit prior to you receiving your new coach. Your dealer may assist you in understanding the limited warranties and with completing all warranty forms for the various appliances and accessories installed in your unit.

Customer Responsibilities

To assist you in avoiding problems with your vehicle, we recommend you do the following:

1. Read the warranty. Go over it thoroughly with your dealer.
2. Inspect the vehicle. Do not accept delivery until you have gone through the coach with the dealer. Newmar has provided a checklist to be used during retail delivery. Check each item on the list, and make sure the dealer does the same. Do not sign this checklist until you have done checked off each item.
3. Ask questions about anything that you do not understand concerning your recreational vehicle.
4. Responsible Use. Your vehicle is designed to be used for recreational or temporary living purposes. It is not designed to be used as a full-time residence or for commercial use. Commercial use means using as a business asset, such as a mobile office or using the vehicle for lease/rental purposes.

NOTICE

The sales literature versus actual specifics to the vehicle's measurements, weights, or quantities may vary.

Dealer Responsibilities

1. A pre-delivery inspection and systems check: thoroughly inspecting the vehicle and the operation of the factory installed components.
2. A customer walk-through to familiarize the customer with the vehicle, its systems and components, and their operation.
3. Delivery of the Owner's Information Package. This package contains the warranty cards and registrations for the vehicle and factory- installed components that carry a separate warranty. The detailed operating and maintenance instructions on these components are also included in this package.
4. Assisting the customer in completing the component registration forms, at the customer's request. To avoid loss of warranty coverage, the dealer should review the limited warranty provisions with the customer, stressing the importance of filing warranty cards and registrations to the component manufacturers within the prescribed time limit.
5. Providing the customer with information regarding warranty and non-warranty work on the vehicle, as well as its separately warranted components, whether the customer is in or out of the area.

Introduction to Newgle

What is Newgle?

Welcome to the wonderful world of Newgle! Our free online knowledgebase provides you with coach information directly from Newmar, as well as our manufacturers and suppliers. Content is added and updated regularly and is only available to current coach owners and certified technicians. As part of Newmar's seamless service promise, your questions can be answered quicker than ever before with just a few clicks on Newgle's search-focused platform.

Newgle consists of nearly a dozen categories, hundreds of knowledge articles, and thousands of parts with associated coach models and years, files, and links. Finding coach model and year-specific information is no longer a headache or a chore, and it will only get better from here!

IMPORTANT

Newgle is an ever-changing knowledgebase. The Newgle Team strives to introduce new features and content regularly to improve the site. The included screenshots and navigational instructions may change without notice. Always refer to Newgle for the most up-to-date version of this content.

How Do I Access Newgle?

Visit Newgle at <https://newgle.newmarcorp.com> to register for an account.



CUSTOMER ACCOUNTS

If you own a Newmar coach, click the link associated with an owner account, "Coach Owner Account Request." You will be asked to provide your coach information and some basic contact information, allowing the Newgle Team to verify ownership and set up an account just for you!

Once your account has been created, you will receive a verification email, which will include your new username and a link to create a password. The email address you provide when registering for an account will be used as your username, as well as for all Newgle-related communication, including account credentials, password resets, or any special updates from the Newgle team.

IMPORTANT

This link is only valid one time. Please use the direct URL - <http://newgle.newmarcorp.com> - for future access to the site.

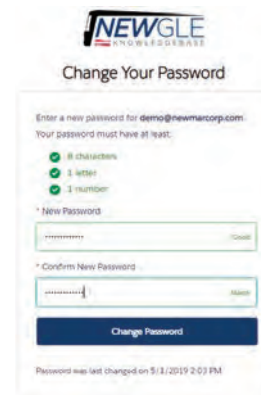
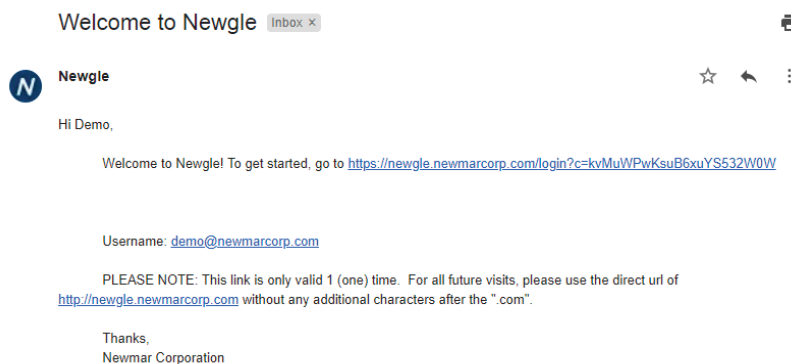

If you already have a Newgle account but have since purchased a different coach, please request a new account to ensure that we have the most up-to-date information in our system. Your login credentials may or may not change pending the newly provided email address.

How Do I Navigate the Site?

The Newgle logo is available at the top of every page throughout the site. Click on the logo at any time to return to the Home page. The Home page boasts a search bar, any pinned knowledge articles, the category drop-down list, and a link to the user's profile.



SEARCH BAR

The Newgle search bar is available on every page, making it possible for you to conveniently initiate a search anytime from anywhere within the site. Effective search queries include a:

- general search term (i.e. hydronic heating)
- vendor model number (i.e. CH50)
- product name (i.e. Oasis)
- Newmar part number (i.e. 127823)
- manufacturer (i.e. ITR)



Search results will immediately populate and often include products (parts), files, links, and knowledge articles. These results can then be refined by using the filter on the left side of the page using one or more of the following definitions:

- Year (i.e. 2019)
- Model Name (i.e. London Aire)
- Model Abbreviation (i.e. LADP)
- Product (Newmar part #)
- Product Code (Vendor model #)
- Product Description
- Product Group
- Product Category
- Product Sub-Category

For more information about this topic, as well as for more tips and tricks, refer to the article in Newgle titled “How Do I Find What I Need in Newgle?”

What Type Of Information Will I Find?

Once a product is selected from search results or via site navigation, additional details will be displayed, such as:

- product name and description
- specifications and features
- relevant coach models and years
- files, links, and knowledge articles
- an image sourced straight from NewPar, Newmar's online parts catalog (when available).

FILES AND LINKS

You may access content provided directly from the product manufacturers, vendors, and suppliers. Files are typically in a PDF format and the text is searchable, making it easier than ever to find specific information within the document. Product links are sourced directly from the provider's or other relative websites (i.e. YouTube). Documentation found in the files and links include, but are not limited to:

- Operation and User Guides
- Installation and Maintenance Manuals
- Troubleshooting Guides and Service Manuals
- Technical Guides, Diagrams, and Schematics
- Work Instructions and Service Bulletins
- Parts and Accessories Catalogs
- Product Specifications and Reviews
- Safety Information and Warranty Registration Forms
- FAQ's and Videos

KNOWLEDGE ARTICLES

Knowledge articles are customer-friendly documentation written or revised by Newmar's Technical Publications department. These may contain basic operating instructions, additional safety information, product overviews, how-to and troubleshooting articles, as well as related videos produced by Newmar. Our owner's guides for each new model year are built from such articles, as they are meant to be an operational overview or "quick start" for a customer.

What If I Can't Find What I'm Looking For?

Just like the RV industry, our site is always growing, changing, and improving. Our dedicated, full-time Newgle staff is working diligently to provide you with access to more model- and year-specific information directly from the manufacturers as quickly as we can. Help us prioritize our efforts!

If you have suggestions for a better user experience, or if you are unable to locate the information you need, feel free to contact us:

- Email the Newgle team: newgle@newmarcorp.com
- Email the Customer Service team: customerservice@newmarcorp.com
- Call to speak to a Customer Service Brand Specialist: 1-800-731-8300 (option #2)

How Can I Update My Information?

In the upper right corner of every page, you have the ability to access and make changes to your user profile:

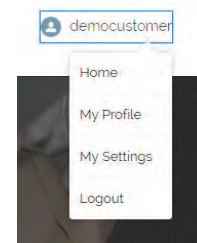

HOME

- Quickly return to the Home screen.

MY PROFILE

- Easily view your account and contact information, such as your name, username, last login, selected time zone, email address, phone numbers, etc.
- Click "Edit" to update your account or contact information or add background information in the "About Me" section. By default, this information is not viewable by other Newgle users, but we ask that you keep it up-to-date to ensure you receive important information from Newmar.

MY SETTINGS

- Easily view and update your account username, password, and email address.
- Select your preferred location and update it as you travel across the country.
- Choose the desired visibility for your contact information.
 - Restricted: Visible to Newmar only.
 - Members: Visible to logged-in members.
 - Public: Visible to anyone viewing pages that don't require login (not applicable to Newgle).

LOGOUT

- End your Newgle session quickly with the click of a button.

NOTICE

Any technical information published in Newgle is only intended for use by qualified, Newmar-authorized service technicians. Newmar is not responsible for misuse of this information.

Having Trouble Logging In?

After three failed login attempts, your account will become locked for 15 minutes. Wait 15 minutes, and try to login again. If you forget or lose your password, or if it is no longer working, you can reset it at any time from the login screen. Click on the “Forgot Your Password?” link, and enter your username (the email address you used when registering for your account), then click or tap “Continue.” You will receive an email with a link to reset your password. Remember, this link is only valid one time. Please use the direct URL - <https://newgle.newmarcorp.com> - for future access to the site.



⚠ IMPORTANT

You will be asked to change your password every 180 days to ensure the highest level of security available. A new password cannot match any of the previously-used three passwords. When prompted, follow the onscreen instructions to create a new password that meets all of the requirements.

⚠ IMPORTANT

Your Newgle account may be deactivated after six months of inactivity. Newmar will provide notice prior to deactivation using the email address displayed in your profile.

If you have any questions regarding your account, or if you wish to re-activate your Newgle account, please email the Newgle Team at newgle@newmarcorp.com.

How Do I Find What I Need In Newgle?

Newgle’s all-new site platform is now search-centric! This simply means that you are now able to find what you are looking for much easier and more quickly than ever before, even if you do not know where the content may be located within the site. This article provides general search tips and explains the different types of search filters and views that can be utilized in Newgle to produce the most effective search results.



How Do I Begin Searching For What I Need?

Specific components, items, and parts installed by Newmar, which can be refined by model and year of a coach.

PRODUCTS BY YEAR MODEL

Specific components, items, and parts installed by Newmar, which can be refined by model and year of a coach.



FILES

Attached documentation provided directly from Newmar’s product manufacturers, suppliers, vendors, and distributors. The file results often include owner’s guides, instruction manuals, installation guides, troubleshooting articles, care and maintenance guides, and much, much more.



LINKS

Helpful web addresses of product manufacturers that often contain additional resources such as online warranty registrations, safety information, reference material, contact information, etc.



KNOWLEDGE ARTICLES

Customer-friendly documentation written or revised by Newmar's Technical Publications department. These may contain basic operating instructions, additional safety information, product overviews, how-to and troubleshooting articles, as well as related videos produced by Newmar.



Note: A new search can be initiated anytime from anywhere within the site by simply changing the keywords in the search bar. It is not necessary to return to the home page to initiate a new search. This is a shortcut to use if you mistyped your query, get too deep into the site and get lost, or need to reset the entire refined list (filter) for the search's results.

What Tips and Tricks Can I Use To Find What I Need Quickly?

Even though the search feature already saves you time and energy, there are a few do's and don'ts for searching in the site to produce the most effective search results.

1. **DO NOT** be specific in your initial search. Begin with broad terms and narrow it down after reviewing the results. (e.g.: Instead of searching "Atwood hot water heater," search "water heater." The built-in results filter will help you further narrow your search down to the specific unit installed in the coach.)
2. **DO** use clear, concise **keywords** or **short phrases** in your initial search. Avoid using complete sentences or asking questions in the search bar. (e.g.: Instead of searching "How to connect a Blu-ray player to a Sony TV," simply search "Blu-ray" or "Sony TV." Then you can access manuals, how-to instructions, and relevant articles pertaining to components in a particular coach model and year.)
3. **DO NOT** search using the model and/or year of the coach. Instead, search for the product or topic, then use the filter to narrow your results back to the coach model and year. (e.g.: Instead of searching "2018 Ventana DVD Player," search "dvd player." The built-in results filter will help you further narrow your search down to the specific unit installed in the coach for a particular coach model and year.)
4. **DO** search for the product's model number if it is available. If you know the Newmar part number, you can also use it to initiate a search. (e.g.: Searching "WRF560SEYM" or "130238" will instantly narrow down the results to that specific refrigerator.)
5. **DO NOT** use slang words or abbreviations if they are avoidable. (e.g.: Instead of searching "fridge" or "refer," search "refrigerator.")
6. **DO** feel free to use upper and/or lower case when searching. The search function is not case-sensitive. (e.g.: Searching "TriMark Grab Handle" will produce the same results as "trimark grab handle.")
7. **DO NOT** give up if your search produces no results. Try rephrasing, using different keywords, or generalize your search. (e.g.: Instead of searching "Delta pull-down faucet," search "faucet.")

What If My Search Does Not Produce Any Results?

If initiating a search produces no results, it most likely does NOT mean that the information is not available. Like Google, sometimes you need to make adjustments. Here are some things you can try:

- Try a different keyword or search term.
- Generalize your search. Being too specific will narrow the results.
- Be more concise. Remove words or use smaller phrases. Less is more.
- Check the spelling of all words, and check for any mistaken characters (O/O, S/5, B/8, I/L, U/V, etc.)
- If you know the product code (manufacturer's model number, but search is not producing any results, try using less of the product code. Manufacturers often add characters to denote color, style, or size of the product. These types of additions do not typically affect the end result. (e.g.: WRF560SEYM05 can be found without the "05" at the end.)
- Special characters should NOT affect your search results, but in the event that they do, remove any hyphens/dashes, spaces, etc. from items (e.g.: TM-102, Shower Mi\$er, etc.).

What If My Search Produces Too Many Results?

There are instances when a search produces too many results and too much information, but it is still best to begin with a general search instead of a specific one, as these often produce less (or no) results. Adding or clearing filters will only produce results within the search that was originally initiated in the search bar. However, use the terms and phrases in the results to tweak a search if necessary.

Changing a word or term to one the search engine recognizes and relates to other content may produce more precise results, narrowing your list of results (e.g.: Searching “push start” may bring up some results, but by reviewing them, you may notice “keyless ignition” is used as a synonym and may produce better results if used as the subject of a new search.)

In most cases, you will get results of some kind after initiating a search, and it may be necessary to narrow down your search results by filtering the content. Note: Not all content is available from the main results page. It may be necessary to click the “View More” button for each heading to view the full list of relevant content. There are a few different ways you can adjust the filters and views within these result sets.

PRODUCTS BY YEAR MODEL

This view only presents coach model and year combinations that are relevant to the specified Product (part/item). Products by Year Model supplies the year and model the part number was used by Newmar. This information is sourced from NewPar, Newmar’s online parts catalog. There are two options that will produce the same screen, filter, and results: clicking the “View More” button in the top right corner or the “Products by Year Model” in the left sidebar. Click one of these options.

YEAR	MODEL NAME	MODEL ABBREV	PRODUCT	PRODUCT CODE	PRODUCT DESCRIPTION	PRODUCT GROUP	PRODUCT CATEGORY
2018	Marathon 470 470L	470L	48954	42334	Upper Deck Seating System - Chair	Upper Deck	Chair
2018	Marathon 470 470L	470L	48954	42334	Upper Deck Seating System - Chair	Upper Deck	Chair
2018	Marathon 470 470L	470L	48954	42334	Upper Deck Seating System - Chair	Upper Deck	Chair
2018	Marathon 470 470L	470L	48954	42334	Upper Deck Seating System - Chair	Upper Deck	Chair

Once the search is initiated using this view, you can narrow your results even further by using information displayed. Narrow your search in the “Refine by” sidebar on the left by viewing the information that is given about the products shown. This will help you know where to place the information you know about the product to get the best results.

YEAR	MODEL NAME	MODEL ABBREV	PRODUCT	PRODUCT CODE	PRODUCT DESCRIPTION	PRODUCT GROUP	PRODUCT CATEGORY
2018	Marathon 470 470L	470L	48954	42334	Upper Deck Seating System - Chair	Upper Deck	Chair
2018	Marathon 470 470L	470L	48954	42334	Upper Deck Seating System - Chair	Upper Deck	Chair

Within this sidebar, multiple fields can be populated, but each search magnifying glass must be clicked on or the “Enter” key must be pressed to initiate one filter at a time. Any refinement that is not initiated will remain yellow until that filter is applied. Fields can be “cleared” one at a time also, allowing changes to be made quickly and easily.

When using the Products by Year Model view, the results can also be sorted by clicking the dropdown icon next to the search result count or column header. Clicking the header a second time changes the order of the sort. The information provided includes:

- Year – Coach production year (e.g.: 2018)
- Model Name – Coach model name (e.g.: Dutch Star). These should always be written just as Newmar writes them; never combine words “baystar,” “dieselpusher,” etc.
- Model Abbrev – Coach model abbreviation provided by Newmar (e.g.: DSDP)
- Products – Newmar’s part number, as added to Newgle by manufacturer, not vendor, same as Infor and NewPar numbers (e.g.: 135798)
- Product Code – Manufacturer’s model number (e.g.: KDL-32W600D)
- Product Description – Manufacturer’s product description (e.g.: Sony 32” HD TV w/ Built-in WiFi)
- Product Group – grouped products by manufacturer (e.g.: Sony Televisions)
- Category – general breakdown by type of product found in the coaches (e.g.: Entertainment Systems)
- Subcategory – grouped by type of the category (e.g.: Televisions)

FILES

This view only presents files (attachments) with the search terms included within the title or body of the file. The information provided for each result includes: file title, size, extension, and last modified date. Files are searchable, so even if the keyword(s) used in search are not in the file title, the result will still appear if it is used within the body of the document.

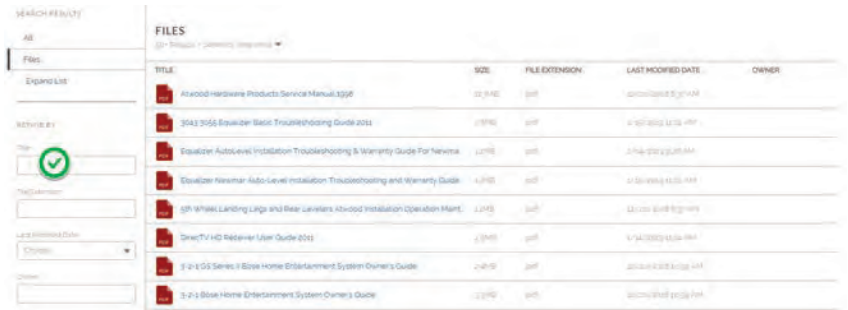

TITLE	SIZE	FILE EXTENSION	LAST MODIFIED DATE	OWNER
Atwood Hardware Products Service Manual 1396	22.34 KB	pdf	2019/08/28 11:11 AM	
2013 2016 EquiStar Bath Troubleshooting Guide 2013	1.97 MB	pdf	4/10/2013 12:39 AM	
Troubleshooting Auto-Level Installation Troubleshooting & Warranty Guide For Newmar	1.17 MB	pdf	1/14/2013 12:05 AM	
EquiStar Newmar Auto-Level Installation Troubleshooting and Warranty Guide	1.17 MB	pdf	1/14/2013 12:05 AM	
SP White Landing Legs and their variants Atwood Installation Operation Maint.	1.14 KB	pdf	11/20/2013 12:05 AM	
SmartTV HD Receiver User Guide 2013	2.2 MB	pdf	1/14/2013 12:05 AM	
2 in x 6.5 Series 3 Bose Home Entertainment System Owner's Guide	4.94 MB	pdf	2013/11/28 11:09 AM	
5 in x 6 Bose Home Entertainment System Owner's Guide	12.97 MB	pdf	2013/11/28 11:09 AM	

EXAMPLE: CUMMINS OWNER'S MANUAL

1. Search term: Cummins (Results: 5+ product links)
2. Click “Files” under the Search Results panel on the left sidebar OR click “View More” to see 22 file names containing the word “Cummins.”
3. Type “manual” in the Title box in the “Refine By” sidebar to narrow down the list to 11 results.
4. Click the file title that best fits your search.

PRODUCT LINKS

This view only presents links with the exact search criteria included in the title of the link. If the word(s) from the search are not in the title of the link, no link results will display. If they are in the title, it will display all links with that title, regardless of the product. You can refine the Product Links by the Newmar part number or by keywords in the link. Note: Link titles may display more than once and depends on how many products the link is connected to within the site.



PRODUCT	PRODUCT LINK
134708	134708 Landing System 625 Series Brochure
134708	134708 Custom-Buildance Landing System/Ident Position
134708	134708 Landing System 625/625B Series/Ident Position

EXAMPLE: REFINE SEARCH BY PRODUCT (PART NUMBER)

1. Search term: Bose (Results: 5+ product links)
2. Click “Product Links” under the Search Results panel on the left sidebar OR click “View More” to see 22 manufacturer links containing the word “Bose.”
3. Type “134708” in the Product box in the “Refine By” sidebar to narrow down the list to two results for this product.
4. Click the link title to go directly to the website, or click on the Product number to view the product’s detail page in Newgle.

EXAMPLE: REFINE SEARCH BY TERMS WITHIN PRODUCT LINKS

1. Search term: Dometic Toilet (Results: 5+ product links)
2. Click “Product Links” under the Search Results panel on the left sidebar OR click “View More” to see 50+ manufacturer links containing the words “dometic toilet.”
3. Type “operation” in the Product Link box in the “Refine By” sidebar to narrow down the list to 5 results containing operation manuals.
4. Click the link title to go directly to view the file, or click on the Product number to view the product’s detail page (and other relevant files) in Newgle.

KNOWLEDGE ARTICLES

This view presents any written documentation (knowledge articles) that contain the search terms. Articles will be sorted based on how many terms match the article title or content within the article. Note: Most of the knowledge articles are written as overviews, operational instructions, and basic how-to's, etc. This type of article is NOT intended to provide technical documentation such as troubleshooting, prints or diagrams, etc.

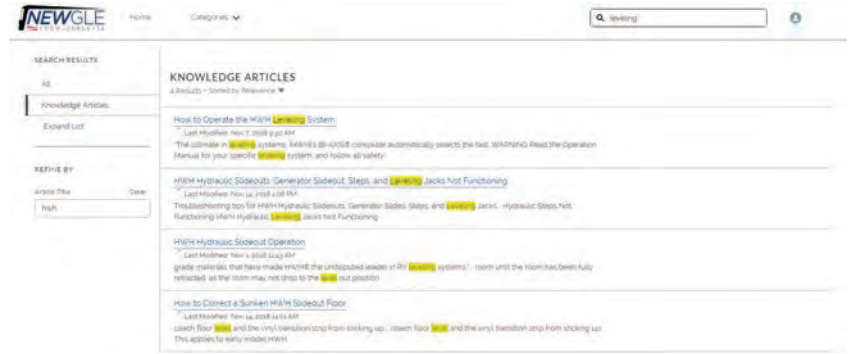

Some of these articles are truly functional (what does this switch do? how does it function? etc.), and some even include short videos. Our owner's guides for each new model year are built from such articles, as they are meant to be an operational overview for a new customer or a customer who requires a review of their walkthrough (e.g.: Sony Smart TV - At first, the system will try to match the search word-for-word (AND scenarios, Sony+Smart+TV), and eventually narrow down to just finding single words "Sony" OR "Smart," OR "TV").

Customer Service Promise

As part of Newmar's seamless service promise, your questions can be answered quicker than ever before with just a few clicks on Newgle's new search-focused platform. Finding coach model and year-specific information is no longer a headache or a chore, and it will only get better from here! If you have suggestions for a better search experience, new keywords or search terms, or if you are unable to locate the information you need, please contact us!



Email the Newgle team: newgle@newmarcorp.com
 Email the Customer service department: customerservice@newmarcorp.com
 Call toll free: 1-800-731-8300 (option #2).

Safety Notices

Reference is made to the following terms throughout Newgle and the Owner's Guide: Danger, Warning, Caution, Important, and Notice. These terms indicate important information that must be understood and followed.

Safety Definitions

⚠ DANGER

DANGER indicates an imminently hazardous situation that, if not avoided, will result in death or serious injury. Failure to observe a **DANGER** may also result in damage to the equipment or unit.

⚠ WARNING

WARNING indicates a potentially hazardous situation that, if not avoided, could result in death or serious injury. Failure to observe a **WARNING** may also result in damage to the equipment or unit.

⚠ CAUTION

CAUTION indicates a potentially hazardous situation that, if not avoided, may result in minor or moderate injury. Failure to observe a **CAUTION** may also result in damage to the equipment or unit.

⚠ IMPORTANT

IMPORTANT notices are not related to personal injury, but provide additional information to make a step easier or clearer.

⚠ NOTICE

NOTICE indicates information that is not necessary or required, but may prove to be helpful.



SAFETY

This section provides information about Newmar's compliance requirements, placards and labels, and seat-belt safety. It also includes information about the safety components installed in your coach, including your smoke and carbon monoxide detectors, emergency exits, and much more.

Safety Resources and Compliance Requirements

This article provides information about Newmar's safety and compliance requirements.

Resources

- Recreation Vehicle Safety and Education Foundation (RVSEF)
- Transport Canada (TC)
- National Highway Traffic Safety Administration (NHTSA)

Compliance Requirements

Newmar motorhomes meet or exceed compliance for the following agencies:

UNITED STATES

- Federal Motor Vehicle Safety Standards (FMVSS)
- Nebraska and Washington State Seals
- National Fire Protection Association (NFPA) 1192 through Recreation Vehicle Industry Association (RVIA)
- National Fire Protection Association (NFPA) 70 National Electrical Code
- Ford Qualified Vehicle Modifiers (QVM) (Ford Chassis Only)
- Carb Compliant Phase 2

CANADA

- Canada Motor Vehicle Safety Standards (CMVSS)
- Federal Motor Carrier Safety Administration (CSA Z 240)
- Canadian Electrical Code through QAI Laboratories

Placards and Labels

A variety of placards and labels are located throughout your coach. These are installed to aid in the operation of a component, or to warn of potential dangers while operating a specific appliance, accessory, or system.

IMPORTANT

Reading, understanding, and heeding all such labels and placards is critical to the safe, efficient use of your coach.

These will include warnings regarding the electrical system, propane gas system, fueling the coach, and much more. It is important to read these placards and warnings to ensure the safety and proper operation of the item. Examples of such labels are provided; one of these labels may be affixed adjacent to your propane tank, if equipped.

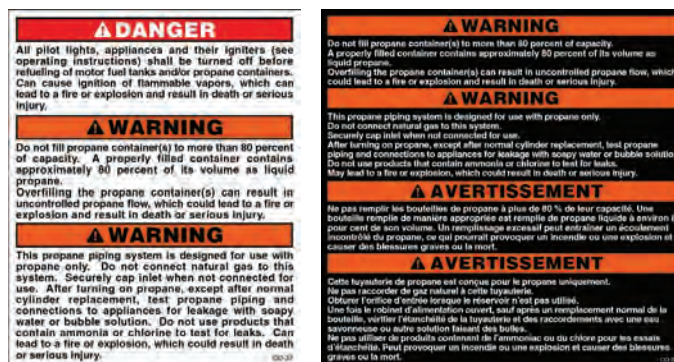

Before Driving Away

Provides a brief list of procedures that will aid in your driving safety and extend the life of your coach.

⚠ WARNING

Prior to driving your vehicle, be sure you have read your entire owner’s guide and that you understand your vehicle’s equipment completely. Read and understand all of the instructions and precautions in this owner’s guide and the chassis manufacturer owner’s manual before operating your new coach.

Listed below are some safety precautions that must be adhered to while your coach is in motion. These precautions, as well as others that involve possible damage to equipment, are also listed in the appropriate areas in this manual.

There are various adjustments that need to be made prior to starting and moving the vehicle. Among them are the driver’s seat, the tilt steering, and the exterior side view mirrors, as well as checking the rear view monitoring system. In addition, the following procedures will aid in your driving safety and extend your equipment’s life.

- Windows, mirrors, and light lenses are to be clean and unobstructed.
- Tires should be checked for proper cold inflation pressure.
- Wheel lug nuts should be checked for proper tightness.
- Fluid levels, including engine oil, transmission fluid, coolant, power steering fluid, brake fluid, and windshield washer solvent, should be checked and filled, if necessary.
- Disconnect the unit from power. Store the sewer and water supply hoses, as well as shoreline power cords.
- Secure all cargo in the storage compartments in the event of a sudden stop.
- Verify that the step has retracted prior to engine ignition.
- Know the overall height of your coach to avoid overhead damage from low clearance bridges, overpasses, awnings, etc.

Driving In Dangerous Conditions

⚠ WARNING

While driving on slippery surfaces, use care when accelerating or decelerating. Skidding and loss of vehicle control may be the result of abrupt changes in speed.

⚠ WARNING

The cruise control is not to be operated on icy roads, extremely wet roads, winding roads, heavy traffic, or in any other traffic situation where a constant speed cannot be maintained.

⚠ WARNING

Never operate a vehicle if a difference in braking efficiency is noticeable. Extreme terrain and adverse weather may affect the handling and/or performance of your vehicle.

⚠ WARNING

Driving through water deep enough to wet the brakes may affect the stopping distance or cause the vehicle to pull to one side. If you have driven through deep water, check the brake operation in a safe area to be sure they have not been affected.

Seat Belt Safety

One of the most important safety features in your vehicle is the restraint system. Research has shown that seat belts save lives. And they can reduce the seriousness of injuries in a collision. Some of the worst injuries happen when people are thrown from the vehicle. Everyone in a motor vehicle needs to be buckled up at all times.

⚠ WARNING

It is extremely dangerous to ride in a cargo area, inside or outside of a vehicle. In a collision, people riding in these areas are more likely to be seriously injured or killed. Do not allow people to ride in any area of your vehicle that is not equipped with seats and seat belts. Be sure everyone in your vehicle is in a seat and is using a seat belt properly.

How To Operate Your Seat Belts and Restraint System

LAP/SHOULDER COMBINATION RESTRAINTS

1. Enter the vehicle and close the door. Sit back, and adjust the seat.
2. The latch plate of the belt is above the back of your seat. Grasp the latch plate, and pull out the belt. Slide the latch plate up the webbing as far as necessary to make the belt go around your lap.
3. When the belt is long enough to fit, insert the latch plate into the buckle until you hear a “click.”
4. Position the lap belt across your thigh, below your abdomen. If you need the lap portion tighter, pull up a bit on the shoulder part. A snug belt reduces the risk of sliding under the belt in a collision. Position the shoulder belt on your chest so that it is comfortable and not resting on your neck. The retractor will withdraw any slack in the belt.
5. To release the belt, push the release button on the buckle.

LAP BELT RESTRAINTS WITHOUT A SHOULDER HARNESS

1. Slide the latch up the webbing as far as necessary to make the belt go around your lap.
2. Insert the latch plate into the buckle until you hear a “click.”
3. Adjust and position the belt low and snug across your hips by removing the slack from the belt.
4. To release the belt, push the release button on the buckle.

There are different sizes and types of restraints for children from newborn to near-adult size children. Use the restraint that is correct for your child:

- The restraint must be appropriate for your child’s weight and height. Check the label on the restraint for this, too.
- Carefully follow the instructions that come with the restraint. If you install the restraint improperly, it may not work when you need it.
- Buckle the child into the restraint exactly as the manufacturer’s instructions have directed.

How To Maintain Your Seat Belts and Restraint System

Periodically examine your restraint equipment to be sure it functions correctly and to be sure there are no worn or broken components that either needs repair or replacement. Damaged parts must be replaced immediately. Do not disassemble or modify the system.

WARNING

If you wear your safety belt improperly, both the effectiveness and comfort will decrease.

NOTICE

Some shoulder belts can be adjusted upward or downward to help position the belt away from your neck. Push on the anchorage cover to release it, and then move it up or down to the position that serves you best.

WARNING

Always wear your seat belt when the vehicle is in operation.

IMPORTANT

Each belt is intended to restrain only one person at a time. Do not put two people under one belt.

CAUTION

Never attempt to restrain a child in your lap using the lap belt around both you and the child. The child could be severely injured or killed in the event of a collision.

IMPORTANT

Seat belts are matched sets. Do not mix or use this belt or parts of this belt with other types of seat belts.

IMPORTANT

Everyone in your vehicle needs to be buckled up at all times. Every state in the United States and all Canadian provinces require that small children ride in proper restraint systems. This is the law, and you can be prosecuted for ignoring it.

WARNING

A frayed or torn belt could rip apart in a collision and leave you with no protection. Inspect the belt system periodically, checking for cuts, frays, or loose parts. Damaged parts must be replaced immediately. Do not disassemble or modify the system. Seat belt assemblies must be replaced after an accident if they have been damaged (bent retractor, torn webbing, etc.)

Restraint equipment must be replaced after an accident if they have been damaged. If there is any question regarding belt or retractor condition, replace the belt. It is a good idea to have your restraint system inspected during each periodic scheduled maintenance session. If the belts need cleaning, use a mild soap solution or lukewarm water. Do not remove the belts from the vehicle to wash them.

Fire Safety

This article provides information about the smoke detectors and fire extinguishers installed in the coach.

The possibility of fire exists in all areas of life, and the recreational lifestyle is no exception. Recreational vehicles are complex machines made up of many materials, some of which are flammable. Like most hazards, the possibility of fire can be minimized, if not totally eliminated by recognizing the danger and practicing common sense safety and maintenance habits. For safety reasons, your unit is furnished with both a fire extinguisher and a smoke alarm.

⚠ WARNING

Do not bleach, dye or clean the belts with chemical solvents or abrasive cleaners. This may severely weaken the fabric. In a crash, they might not be able to provide adequate protection.

<p style="text-align: center;">⚠ WARNING</p> <p>Test smoke alarm operation after vehicle has been in storage, before each trip, and at least once per week during use. Failure to do so can result in death or serious injury.</p> <p style="text-align: center;">⚠ AVERTISSEMENT</p> <p>Vérifier l'avertisseur de fumée si le véhicule a été entreposé, avant chaque déplacement et au moins une fois par semaine en service. L'absence de vérification peut entraîner des blessures graves ou la mort.</p> <p style="text-align: right; font-size: small;">DD-58</p>	<p style="text-align: center;">⚠ DANGER</p> <p>Vehicles and equipment powered by internal combustion engines and placed in recreational vehicles can cause carbon monoxide poisoning or asphyxiation, which could result in death or serious injury.</p> <p>The flammable liquids used to power these items can cause a fire or explosion, which can result in death or serious injury.</p> <p>To reduce risk:</p> <ol style="list-style-type: none"> 1. Do not ride in the vehicle storage area when vehicles are present. 2. Do not sleep in the vehicle storage area when vehicles are present. 3. Close doors and windows in walls of separation (if installed) when any vehicle is present. 4. Run fuel out of engines of stored vehicles after shutting off fuel at the tank. 5. Do not store, transport, or dispense fuel inside this vehicle. 6. Open the windows, openings, or air ventilation systems provided for venting the transportation area when vehicles are present. 7. Do not operate propane appliances, pilot lights, or electrical equipment when motorized vehicles are present.
--	--

⚠ DANGER

If a fire occurs in the vehicle, evacuate the vehicle as quickly and as safely as possible. Consider the cause and the severity of the fire and the risk involved before trying to extinguish it. If the fire is major or fuel fed, move away from and stand clear of the vehicle and wait for emergency assistance to arrive.

Smoke Detectors

The smoke detector installed in your coach is operated on a 9 volt battery. The smoke detector is mounted on the ceiling in the living area of the unit. Read the operating instructions for details on the testing and care for this important safety device.

Test the smoke detector after the unit has been in storage, before each trip, and at least once a week during use. Check your smoke detector for the manufacturer's expiration date. The battery needs to be tested periodically and replaced once a year and/or when the low battery signal sounds.

When cleaning the case on any of the detectors, use a damp cloth or paper towel. Do not spray cleaners or wax directly into the case as it may cause false alarms.

⚠ IMPORTANT

The detector should never be disabled because of nuisance or false alarm from cooking smoke or a dusty furnace. Ventilate the unit with fresh air and the alarm will shut off. Never disconnect or remove the battery from the smoke alarm.

Fire Extinguishers

The fire extinguisher is rated for Class B (grease, gasoline, diesel fuel, flammable liquids) and Class C (electrical) fires. These are the most common types of fires in vehicles. Fire extinguishers are mechanical, pressurized devices. Care must be exercised when they are handled.

The extinguisher should be inspected at least once a month. More frequent inspections may be required if the extinguisher is exposed to the weather or to possible tampering. Do not test the extinguisher by partially discharging, as it will cause a loss of pressure. Your fire extinguisher must be maintained as the operator's manual instructs for proper and safe operation.

Read the operator's manual and the instructions on the fire extinguisher. Be sure to know how and when to use the extinguisher and where it is located.

⚠ DANGER

Failure to comply could result in an increased risk of fire, explosion, asphyxiation, serious injury, or death.

Carbon Monoxide Safety

This article provides information about the safe use of carbon monoxide-producing coach components. Carbon monoxide is a colorless, tasteless, odorless gas. It is a by-product of the burning of fossil fuels (gasoline, propane gas, diesel fuel, etc.). The chassis and generator engines, furnaces, water heater, propane gas refrigerator, and range produce carbon monoxide constantly while they are operating.

Carbon Monoxide Poisoning

If you, or anyone else, experience any of the following carbon monoxide poisoning symptoms, exit the coach immediately. Seek medical attention if the symptoms persist. Shut down the coach, and do not operate it until it has been thoroughly inspected and repaired.

- Dizziness
- Nausea
- Vomiting
- Muscular twitching
- Throbbing in the temples
- Inability to think coherently
- Weakness and/or sleepiness
- Intense headaches

Carbon Monoxide (CO) Detectors

The detector is equipped with a “sensor activation strip,” which must be removed for the detector to operate properly. This should have been done during the dealer’s Pre-Delivery Inspection. Please check the detector to verify that the activation strip has been removed. The CO detectors are self-contained and do not require any maintenance other than normal cleaning and dusting.

Install battery or batteries into the battery holder, and observe the polarity. After approximately 30 seconds, the battery-operated detector will begin monitoring for carbon monoxide, making the device operational. The test/reset button is used to test the detector’s electronics and reset the detector after an alarm. Test the detector weekly.

DANGER

Carbon monoxide is deadly. Read and understand the following precautions, as well as any warning labels in your coach, to protect yourself and others from the effects of carbon monoxide poisoning.

WARNING

Do not sleep in this area. Carbon monoxide or other harmful vapors could enter the area through the floor openings, which could result in death or serious injury.

AVERTISSEMENT

Ne pas dormir dans cette aire. Du monoxyde de carbone ou d'autres vapeurs nocives pourraient y pénétrer par des ouvertures dans le plancher et entraîner des blessures graves ou la mort.

DANGER

Vehicles and equipment powered by internal combustion engines and placed in recreational vehicles can cause carbon monoxide poisoning or asphyxiation, which could result in death or serious injury.

- The flammable liquids used to power these items can cause a fire or explosion, which can result in death or serious injury.
- To reduce risk:
1. Do not ride in the vehicle storage area when vehicles are present.
 2. Do not sleep in the vehicle storage area when vehicles are present.
 3. Close doors and windows in walls of separation (if installed) when any vehicle is present.
 4. Run fuel out of engines of stored vehicles after shutting off fuel at the tank.
 5. Do not store, transport, or dispense fuel inside this vehicle.
 6. Open the windows, openings, or air ventilation systems provided for venting the transportation area when vehicles are present.
 7. Do not operate propane appliances, pilot lights, or electrical equipment when motorized vehicles are present.

WARNING

Do not block the tailpipes or exhaust ports. Do not situate the vehicle in a place where the exhaust gases have any possibility of accumulating either outside, underneath, or inside your vehicle or any nearby vehicles. Outside air movements can carry exhaust gases inside the vehicle through windows or other openings remote from the exhaust outlet. Operate engines, carbon monoxide-producing systems, or components only when safe dispersion of exhaust gases can be assured. Monitor outside conditions to be sure that exhaust continues to be dispersed safely.

WARNING

Under no circumstance should you operate any engine while sleeping. When you are sleeping, you are not able to monitor outside conditions to assure that engine exhaust does not enter into the coach. Check the exhaust system frequently for damage. If damage is found, do not operate the system. Never modify the exhaust system(s) in any way.

Propane System Overview

This article provides details about the propane fuel system in a Newmar coach, including propane safety and maintenance.

Your coach may be equipped with an ASME (American Society of Mechanical Engineers) approved propane tank. This tank is controlled with an automatic pressure regulator. The propane tank contains liquid petroleum gas under high pressure. As the fuel is used, the liquid gas vaporizes and passes through the tank valve to a regulator that automatically reduces the pressure. The low-pressure gas is then distributed to the appliances throughout the pipe manifold system.

The components relating to the propane gas system in your coach have been approved for use in recreational vehicles by a nationally recognized testing laboratory. Propane gas is a clean-burning dependable fuel when properly handled.

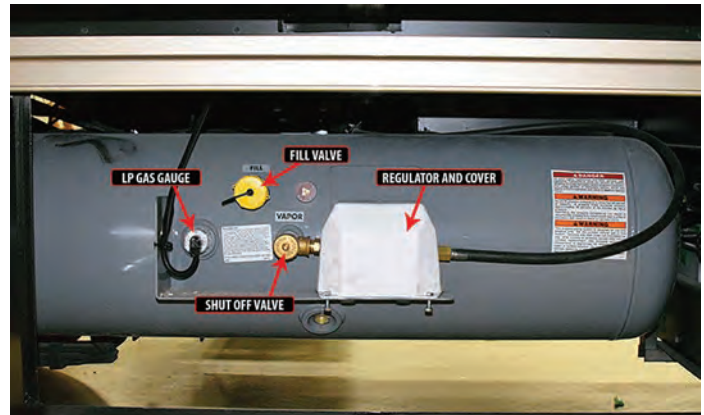

Propane Safety

PROPANE (LP) DETECTOR

The propane detector in your coach is located in the main living area close to the floor. It is wired to the 12 volt electrical system in your unit and may be controlled by a switch in the front overhead cabinet. Operating instructions and a test button are located on the face of the detector. The propane detector should be tested after the vehicle has been in storage, before each trip, and at least once per week during use.

Never attempt to repair the propane detector. Do not remove the fuse or disconnect wiring to the propane detector. If the propane detector will not function, check for 12 volt power at the detector. If an issue is found, or if the 12 volt electric circuit not operational, repair the 12 volt issue or replace the propane detector.

LP DETECTOR LED INDICATORS

- **Warm-Up Mode:** When in this mode, the indicator will remain green for approximately 30 seconds and emit a single “chirping” sound, followed by silence.
- **Normal Operating Mode:** When in this mode, the indicator will flash green every eight seconds and no alarm will sound.
- **Alarm Silence Mode:** When in this mode, the indicator will flash red rapidly and no alarm will sound. This condition will exist if the alarm has sounded but has been temporarily silenced by pressing the TEST button. The alarm will sound again after four minutes if the LP level remains above 2000 PPM.
- **LP Alarm:** If the LP level at the detector has reached a dangerous level, the indicator will flash red rapidly and emit a pulsing alarm. See Alarm Conditions in the Atwood LP Detector’s Owner’s Manual if this condition persists.
- **Non-Microprocessor Component Failure:** The indicator will remain orange or red and emit a “chirping” sound every 30 seconds. Press the TEST button to reset. However, if the condition persists, contact an Atwood Service Center.
- **Low Power Failure:** The indicator will remain red and no alarm will sound. If this condition persists after full power is restored to the detector, this alarm could also be indicative of microprocessor failure. In this event, the user should contact an Atwood Service Center.

⚠ IMPORTANT

While in high altitudes or extreme cold weather, a gas shortage may be experienced. Running one appliance at a time can help adjust to this problem.

⚠ DANGER

Exhaust gases contain carbon monoxide (an odorless, colorless, and poisonous gas) produced by burned gasoline, diesel, or propane gas. Items such as the range, furnace, water heater, refrigerator, chassis engine, or generator engine can produce these gases. These fumes should not be inhaled.

⚠ WARNING

Portable fuel-burning equipment, including wood and charcoal grills and stoves, shall not be used inside the coach, as they can cause fire or asphyxiation. Failure to comply could result in serious injury or death.

⚠ WARNING

Do not use coach with a non-operational LP detector.

⚠ IMPORTANT

Never spray any type of aerosol or cleaner directly onto or into the propane detector. Spraying any type of material into the opening on any of these detectors can render them useless, and would not be covered by the manufacturer’s warranty.

Propane Warning Labels

IMPORTANT

Read and understand the following precautions, as well as any warning labels in your coach, to protect yourself and others from the risks of operating an LP system.

The following labels regarding propane safety are strategically placed inside of your coach.

If You Suspect A Gas Leak

If the detector alarms while in use, or if you smell propane or suspect a gas leak (the odor smells similar to rotten eggs or sulfur), follow the warning labels in your coach.

- Immediately turn off all potential sources of ignition (furnace, water heater, refrigerator, stove/range, etc.), and extinguish any open flames, pilot lights, and all smoking materials.
- Do not touch electrical switches.
- Shut off the propane supply at the container valve(s) or propane supply connection.
- Open doors and other ventilating openings.
- Evacuate the unit, and leave the area until the odor clears.
- Consult an authorized service technician for repairs, as the propane system must be checked and leakage source corrected before using again.

Propane System Maintenance

It is recommended to have the propane system inspected by an authorized service technician at least once a year and after every extended trip. This system is tested by both the manufacturer and the dealer; however, leaks may be caused by travel vibrations.

Filling The Propane System

Tank filling should only be performed by trained professionals. Prior to filling the propane tank, turn off all flame or spark-producing appliances, extinguish any smoking items, and turn off the coach engine.

IMPORTANT

All protective covers and caps must be replaced after filling the propane system. Once the valve is closed, securely latch the propane door.

WARNING

While refilling the fuel or propane tank, the engine must be off, all pilot lights must be extinguished, and appliances turned off. The vehicle should be as level as possible, and the service valve should be turned off. Smoking is also prohibited at this time.

⚠ WARNING	⚠ AVERTISSEMENT
<p>This propane piping system is designed for use with propane only. Do not connect natural gas to this system. Securely cap inlet when not connected for use. After turning on propane, except after normal cylinder replacement, test propane piping and connections to appliances for leakage with soapy water or bubble solution. Do not use products that contain ammonia or chlorine to test for leaks. May lead to a fire or explosion, which could result in death or serious injury.</p>	<p>Cette tuyauterie de propane est conçue pour n'être utilisée qu'avec du propane. Ne pas l'utiliser pour du gaz naturel. Bien capuchonner l'entrée de la tuyauterie lorsqu'elle n'est pas raccordée. Après avoir ouvert la vanne du propane, sauf lors du remplacement normal du cylindre, faire un essai d'étanchéité de la tuyauterie de propane et des raccords aux appareils à l'aide d'eau savonneuse ou d'une solution qui produit des bulles. Ne pas effectuer d'essai d'étanchéité à l'aide d'ammoniac ou de chlore. Le non-respect de cette instruction peut causer un incendie ou une explosion, ce qui pourrait entraîner des blessures graves ou la mort.</p>

⚠ CAUTION
<p>Shut off gas supply before disconnecting appliance.</p>
⚠ ATTENTION
<p>Couper le gaz avant de déconnecter l'appareil.</p>
GD0002

⚠ DANGER
<p>Never test for a leak by lighting a match or having an open flame where you suspect leaking gas.</p>

⚠ DANGER	⚠ DANGER
<p>IF YOU SMELL PROPANE</p> <ol style="list-style-type: none"> 1. Extinguish any open flames and all smoking materials. 2. Shut off the propane supply at the container valve(s) or propane supply connection. 3. Do not touch electrical switches. 4. Open doors and other ventilating openings. 5. Leave the area until the odor clears. 6. Have the propane system checked and leakage source corrected before using again. <p>IGNITION OF FLAMMABLE VAPORS COULD LEAD TO A FIRE OR EXPLOSION AND RESULT IN DEATH OR SERIOUS INJURY.</p>	<p>SI VOUS SENTEZ UNE ODEUR DE PROPANE :</p> <ol style="list-style-type: none"> 1. Éteignez toute flamme nue et tout article pour fumeur. 2. Coupez l'alimentation en gaz de l'appareil au réservoir ou au raccordement d'alimentation. 3. Ne touchez pas aux interrupteurs électriques. 4. Ouvrez les portes et toute autre ouverture de ventilation. 5. Quittez les lieux jusqu'à ce que l'odeur ait disparu. 6. Faites vérifier l'installation et colmater toute fuite avant d'utiliser de nouveau. <p>L'INFLAMMATION DES VAPEURS INFLAMMABLES POURRAIT PROVOQUER UN INCENDIE OU UNE EXPLOSION ET ENTRAÎNER DES BLESSURES GRAVES OU LA MORT.</p>

⚠ WARNING
<p>Inspect the propane fill valve for foreign materials before refueling. Introducing foreign material into the fill valve may cause leaking or overfilling, resulting in uncontrolled gas flow and a fire or explosion.</p>

⚠ WARNING
<p>Shut off the propane gas valve when refueling to avoid potential danger from pilot lights igniting fuel fumes. Some appliances, such as the refrigerator, water heater, and furnace, have DSI (direct spark ignition) boards, so it is important that you turn the appliances off when the propane gas is turned off. The ignition in the appliances may continue to spark even if there is no propane gas available.</p>

⚠ WARNING
<p>Propane gas is extremely flammable. Propane gas containers, gasoline, or other flammable liquids shall not be placed or stored inside the vehicle. Propane cylinders are equipped with safety devices that relieve excessive pressure by discharging propane to the atmosphere. Failure to comply could result in serious injury or death.</p>

⚠ WARNING

Do not fill propane container(s) to more than 80 percent of capacity. A properly filled container contains approximately 80 percent of its volume as liquid propane. Overfilling the propane container(s) can result in uncontrolled propane flow, which could lead to a fire or explosion and result in death or serious injury.

⚠ WARNING

This propane piping system is designed for use with propane only. Do not connect natural gas to this system. Securely cap inlet when not connected for use. After turning on propane, except after normal cylinder replacement, test propane piping and connections to appliances for leakage with soapy water or bubble solution. Do not use products that contain ammonia or chlorine to test for leaks. May lead to a fire or explosion, which could result in death or serious injury.

⚠ AVERTISSEMENT

Ne pas remplir les bouteilles de propane à plus de 80 % de leur capacité. Une bouteille remplie de manière appropriée est remplie de propane liquide à environ 80 pour cent de son volume. Un remplissage excessif peut entraîner un écoulement incontrôlé du propane, ce qui pourrait provoquer un incendie ou une explosion et causer des blessures graves ou la mort.

⚠ AVERTISSEMENT

Cette tuyauterie de propane est conçue pour le propane uniquement. Ne pas raccorder de gaz naturel à cette tuyauterie. Obtenir l'orifice d'entrée lorsque le réservoir n'est pas utilisé. Une fois le robinet d'alimentation ouvert, sauf après un remplacement normal de la bouteille, vérifier l'étanchéité de la tuyauterie et des raccords avec une eau savonneuse ou autre solution faisant des bulles. Ne pas utiliser de produits contenant de l'ammoniac ou du chlore pour les essais d'étanchéité. Peut provoquer un incendie ou une explosion et causer des blessures graves ou la mort.

⚠ WARNING

Do not fill propane container(s) to more than 80 percent capacity. Overfilling the propane container can result in uncontrolled propane flow, which can cause fire or explosion. A properly filled container contains approximately 80 percent of its volume as liquid propane. Failure to comply could result in serious injury or death.

⚠ WARNING

When removing or servicing any gas appliance, close the main gas valve on the propane tank to prevent dangerous gas leakage that could result in an explosion and possible serious injury. If a gas leak is suspected, have the system inspected and repaired by a qualified service technician as soon as possible.

Storing A Propane-Equipped Coach

Keep the tank valve closed and all of the appliances turned off when the unit is stored. If any of the Propane gas valves do not close leak-tight by hand, consult a service technician.

On older coaches, an LP switch may be located in the front overhead or toward the bottom of the passenger chair. This switch shuts off power to the propane detector to prevent an unnecessary draw from the battery bank while the coach is in storage.

Newer coaches are wired to the disconnect side of the battery disconnect solenoid to prevent the detector from draining the battery while the coach is in storage with the disconnect turned off. Keep this switch turned on when the coach is in use for the capability of detecting a leak in the propane system.

⚠ CAUTION

Shut off the main gas valve at the tank when the vehicle is not in use.

Servicing The Gas Distribution Lines

The primary gas supply manifold is a black steel pipe running the length of the unit. Most secondary lines leading to the gas appliances are made of copper tubing with flare fittings.

⚠ WARNING

If any of these lines rupture, do not attempt to splice them. Always run a new line. Gas distribution work must be performed by an authorized service technician.

Emergency Exits

This article provides step-by-step instructions for opening and closing emergency exit windows and doors.



Hehr Egress Emergency Exit Window

Select Hehr windows have an opening window pane in the egress window for ventilation. This style of window can also be opened in the event of an emergency.

TO OPEN THE VENT:

1. Unclip and lower the arm.
2. Swing the arm 90 degrees, and push out on the arm until the red handle latches.

TO CLOSE THE VENT:

1. Unclip the red handle from the latch by lifting slightly while pushing outward.
2. Once the latch releases, pull the arm in until the window is closed.
3. Rotate the arm 90 degrees until it latches into the closed position.



IN THE EVENT OF AN EMERGENCY, OPEN THE WINDOW:

1. Remove the screen by pulling out on the red handle.
2. Push and release the lever from the locking hook.
3. Rotate the lever 90 degrees, and push it through the slot in the window frame.
4. Escape through the opening.

Hehr Double-Latched Emergency Exit Window

TO OPEN THE EMERGENCY EXIT DOUBLE LATCH STYLE WINDOW:

1. Flip both latches up to the open position.
2. Push out on the window.

TO CLOSE AND LATCH THE EMERGENCY EXIT DOUBLE LATCH STYLE WINDOW:

1. Pull the window shut while holding the window track with one hand.
2. With the other hand, rotate the latch up until it connects with the track on the window.
3. Press the front side down until it latches.
4. Repeat the steps for the second latch.



Emergency Egress Exit Door and Ladder

This article provides the Newmar-recommended step-by-step instructions for operating the emergency exit door and ladder.

TO USE THE EMERGENCY EGRESS EXIT DOOR:

1. Unlock the deadbolt by turning it in a counterclockwise motion.
2. Make sure the door latch is unlocked.
3. Unlatch and completely open the door to avoid coach damage during ladder extension.
4. Grab and pull the tab to remove the ladder cover, and set it aside.
5. Grab and pull the tab on the Velcro strap to release the ladder.
6. Flip the ladder out, allowing it to extend to the ground.

TO CLOSE THE EMERGENCY EXIT DOOR:

1. Lift the ladder from the bottom, stacking the rungs and pushing the ladder up into the door cavity.
2. Secure it in place with the Velcro strap.
3. Reinstall the ladder cover.
4. Close and latch the door.
5. Lock the door latch by sliding it into the locked position.
6. Lock the deadbolt by turning the deadbolt in a clockwise motion.

NOTICE

This information is generic in nature and may not be specific to your exact coach model and/or year. The emergency egress exit door and ladder is a feature only installed on some coach floor plans.





APPLIANCES

Newmar only uses the most convenient and efficient appliances to make maintaining your coach - and your lifestyle - less of a chore. This category provides detailed information regarding each of the appliances available in your coach, including cooktops and ranges, dishwashers, fireplaces, microwaves and convection ovens, refrigerators, freezers and ice makers, central vacuums, and washers and dryers.

Appliance Data Sheet and Safety Precautions

This article provides information about the appliance data sheet posted in the coach, complete with details about coach-installed equipment. Newmar only uses the most convenient and efficient appliances to make maintaining your coach - and your lifestyle - less of a chore.

Included in your Owner's Information package are valuable documents about your vehicle and its components and systems. The Newmar Owner's Guide does not cover every possible detail of the equipment (standard and/or optional) installed on or in your coach. Consulting the booklets and instruction manuals in this package will help you safely operate, maintain, and troubleshoot these items.

An information sheet is provided containing important information about your coach for your convenience.

- Your coach's Newmar Serial Number. This number is needed whenever making an appointment for service or ordering parts through your Newmar Dealer or Service Center.
- Your coach's Vehicle Identification Number (VIN). The VIN is the legal identification of the completed vehicle and is used by the state for vehicle registration.
- Your coach's Year, Model, Type, and Floorplan.
- Manufacturer, Model, and Serial Number of factory-installed equipment. Use these model numbers to quickly locate relevant information in Newgle about the parts, including links, files, and articles.

⚠ IMPORTANT

Read all of the information and understand the safety and operating instructions included in the Owner's Information Package. To assure full warranty coverage, it is essential that all maintenance instructions are followed.

Thank you for purchasing a quality Newmar product! For your convenience, we have enclosed a serial number list of important equipment installed in the YEAR MODEL FLOORPLAN. The serial number for your unit is - 904627
VIN# 4VZVU1E91JCXXXXX Décor # 290 Wood Color Bermuda Glazed Maple

Description	Model	Serial Number
DASH A/C	RV202058	43XXX2
INVERTER 1	MS2812	WHI-08XXX
WATER HOSE REEL	HOSEMASTER-M	2X5X8
HYDRO HEAT	34900	CH50-34900-0X28-8X94
OASIS DM-12#	DM-12	3X250-0X28-8X95

⚠ IMPORTANT

The manufacturer, model, and serial number of the appliances and accessories installed at the factory in your coach are listed on this label for convenience. It is important that the label remains in the coach for identification purposes. Do not remove or relocate this label.

Appliance Safety

Several labels relating to the use of your propane or electric appliances may be placed throughout your coach. Follow all warnings to prevent coach damage, bodily injury, or death while operating these types of appliances.

Outdoor Kitchen Safety

For coaches equipped with an outdoor cooking area, adhere to all posted warning labels for safe operation.

⚠ DANGER

All pilot lights, appliances, and their igniters (see operating instructions) shall be turned off before refueling of motor fuel tanks and/or propane containers. Can cause ignition of flammable vapors, which can lead to a fire or explosion and result in death or serious injury.

⚠ DANGER

Éteindre les veilleuses, les appareils et leur dispositif d'allumage (voir les instructions d'utilisation) avant le remplissage des réservoirs de carburant et (ou) des bouteilles de propane. L'avitaillement de carburant peut causer l'inflammation spontanée de vapeurs inflammables, ce qui peut causer un incendie ou une explosion et entraîner des blessures graves ou la mort.

AD-05P

⚠ DANGER

Do not use gas cooking appliances for comfort heating. Can lead to carbon monoxide poisoning, which can lead to death or serious injury.

⚠ WARNING

Gas cooking appliances need fresh air for safe operation. Before operating: Open vents or windows slightly or turn on exhaust fan prior to using cooking appliance. Gas flames consume oxygen, which should be replaced to ensure proper combustion. Improper use can result in death or serious injury.

⚠ DANGER

Ne pas utiliser d'appareils de cuisson pour le chauffage des locaux. Une telle utilisation peut causer un empoisonnement au monoxyde de carbone qui peut entraîner des blessures graves ou la mort.

⚠ AVERTISSEMENT

Les appareils de cuisson au gaz nécessitent un apport d'air frais pour fonctionner en toute sécurité. Avant l'utilisation : ouvrir les événements ou entrouvrir des fenêtres ou actionner la hotte avant d'utiliser un appareil de cuisson. Les flammes de gaz consomment de l'oxygène qui devrait être remplacé pour assurer une combustion adéquate. Une mauvaise utilisation peut entraîner des blessures graves ou la mort.

DD-28P

⚠ CAUTION

Shut off gas supply before disconnecting appliance.

⚠ ATTENTION

Couper le gaz avant de déconnecter l'appareil.

⚠ DANGER

Do not store grill until cool to touch. Failure to do so could result in fire resulting in property damage, personal injury or death.

AD-126

⚠ WARNING

When using this outdoor cooking area:

- The vehicle must be level and stabilized.
- Do not violate manufacturers' instructions on required clearances for cooking appliances during use.
- Do not store cooking appliances until cool to the touch.

Can lead to a fire and explosion and result in death or serious injury.

AD-126

⚠ DANGER

IF YOU SMELL PROPANE

1. Extinguish any open flames and all smoking materials.
2. Shut off the propane supply at the container valve(s) or propane supply connection.
3. Do not touch electrical switches.
4. Open doors and other ventilating openings.
5. Leave the area until the odor clears.
6. Have the propane system checked and leakage source corrected before using again.

IGNITION OF FLAMMABLE VAPORS COULD LEAD TO A FIRE OR EXPLOSION AND RESULT IN DEATH OR SERIOUS INJURY.

⚠ DANGER

SI VOUS SENTEZ UNE ODEUR DE PROPANE :

1. Éteignez toute flamme nue et tout article pour fumeur.
2. Coupez l'alimentation en gaz de l'appareil au réservoir ou au raccordement d'alimentation.
3. Ne touchez pas aux interrupteurs électriques.
4. Ouvrez les portes et toute autre ouverture de ventilation.
5. Quittez les lieux jusqu'à ce que l'odeur ait disparue.
6. Faites vérifier l'installation et colmater toute fuite avant d'utiliser de nouveau.

L'INFLAMMATION DES VAPEURS INFLAMMABLES POURRAIT PROVOQUER UN INCENDIE OU UNE EXPLOSION ET ENTRAÎNER DES BLESSURES GRAVES OU LA MORT.

AD-100



Cooktops and Ranges

Style and function meet for a home cooked meal any night of the week, all at your fingertips. Newmar offers several styles and brands of ranges and cooktops for your coach. Whether a gourmet or beginner chef, your cooktop or range will provide you with all of the necessities - and wants - you desire and deserve to prepare meals for you and your family.

Cooktop Cover Overview

This article provides an overview of of the bi-fold or solid surface cover for the range or cooktop.

Your range may be equipped with a bi-fold or solid surface cover that matches your countertop material. This cover helps to protect the burners when they are not in use. Before cooking on the range top, the cover must be in the full upright and folded position, preventing the cover from falling on the range top during cooking.

To use the cooktop, fold up the bi-fold cover or remove the solid surface cover. Store the cover away from the stove prior to use. Some coaches with an induction cooktop may have a solid surface cover with a built-in cutting board.



⚠ IMPORTANT

Never close the cover while the burners are in use and do not use the cover as a griddle. Never use the range while the RV is moving and remember to close the bi-fold cover or reinstall the solid surface cover when the range top is not in use.

Atwood, Dometic, Wedgewood RA/CA/RV/CV Series Propane Cooktop or Range Operation

This article provides basic operation instructions for an Atwood/Dometic/Wedgewood Propane Cooktop (RA, CA, RV, CV Series).

⚠ IMPORTANT

These brief operation instructions are for quick reference only and should not take the place of the complete manual(s) provided by this product’s manufacturer. Refer to the corresponding links and files in Newgle for more details about your product.

Using The Cooktop

The surface burners may feature Matchlit ignition, Piezo-Electric ignition or Electronic ignition.

SURFACE BURNER WITH A MATCHLIT IGNITION:

- Hold a lighted match to the desired surface burner head.
- Place pan on the burner.
- Push in and turn the surface burner control knob to the “LITE” position.
- When the burner lights, adjust the knob to select the desired flame size.
- To extinguish the burner flame, turn the knob clockwise to the OFF position.

SURFACE BURNER WITH A PIEZO IGNITION:

- Place pan on the burner.
- Push in and turn the surface burner control knob to the LITE position.
- Immediately rotate the SPARK knob clockwise several clicks until the burner lights.
- To extinguish the burner flame, turn the knob clockwise to the OFF position.

SURFACE BURNERS WITH AN ELECTRONIC IGNITION:

- Place pan on the burner.
- Turn the desired burner knob counterclockwise to the LITE position. The system will automatically activate the ignition system and the burner will begin to spark repeatedly. This is the “clicking” sound you will hear.
- The burner will light within five seconds and then you can turn the knob to the desired flame size.
- To extinguish the burner flame, turn the knob clockwise to the OFF position.

Using The Oven Ignition System

The oven features a Pilot ignition System. The PILOT must be lit in order for the burner system to function.

LIGHTING THE OVEN PILOT

- Push in oven control knob and rotate counterclockwise to PILOT—PUSH/HOLD.
- PUSH in the knob and HOLD it in while holding a lit match under the pilot.
- Continue to hold the oven control knob in for 5 seconds after pilot is lit. Release knob and verify pilot stays lit.
- Set the oven control knob to maintain the pilot flame. The oven and broiler are now ready for use. The oven pilot flame has been factory set and requires no additional adjustment.

WARNING

When traveling or refueling the Pilot burner must be turned off. To extinguish the flame, push in the oven knob and rotate clockwise to OFF.

LIGHTING THE OVEN BURNER

- Be certain the pilot burner is ON (see above instructions).
- With the oven knob set to PILOT ON, push in and rotate the knob counter clockwise to the desired oven temperature setting or BROIL.

NOTICE

Oven heats to approximately 450°F. Broil is approximately 550°F. Temperatures may vary slightly up or down during the cooking process.

Oven Heat Control and General Use

PREHEATING OVEN

For best results, preheat the oven for 15 minutes before use. For baking, do not select a higher than required temperature to preheat the oven faster, it may have a negative effect on baking results.

AIR CIRCULATION

Warmed air must circulate freely throughout the oven for food to cook properly. To prevent undercooked or burned food:

- Do not cover the bottom of the oven with aluminum foil to catch “over flow”.
- Do not cover or block ventilation holes in the oven broiler shelf (shelf above the burner).
- Do not cover oven racks with aluminum foil.
- Place the food to be baked in the center of the oven with 1” - 2” inches space from the oven wall on all sides allowing at least 1”-2” of space on all sides of the container.
- Do not crowd the oven with assorted pans or block air passage with an oversized pan.
- Maximum pan – 13 x 9 x 2 inch. Maximum cookie sheet – 14 x 10 inches.
- Shiny metal pans reflect the heat; lighter browning will occur. Best used for cookies.
- Dark pans or pans with anodized bottoms will absorb heat.
- Oven-proof glassware will reduce the oven temperature unless used for pies or bread. Simply follow the baking recipe.

Do not use cookware that extends over the ventilation holes or rests too close to the oven walls. They will ultimately distort the cooking time or cooking results of your food.

Source: Atwood AP Gas Range and Slide-In Cooktops Operation, Installation, and Maintenance Manual



Fireplaces

The fireplace provides instant comfort and ambiance to your home away from home. Your fireplace is a 120 volt electric plug-in fireplace, complete with a thermostat-controlled, fan-forced heater. The fireplace may be operated using the flame-only function with realistic flames, or turn on or off the heat function, providing you with flames and heat. Some models have an adjustable interior light, flame speed control, and/or a timer setting, and some can even be operated using a remote control.

Greystone Electric Fireplace Operation (PD2616F)

This article provides basic operation instructions for a Greystone Electric Fireplace (Model PD2616F).

Operating Instructions

Ensure that all controls are in the “OFF” position before plugging the appliance in to a properly grounded electrical outlet. The control panel of the appliance is located behind the wire grate above the glass on the front.

Control Panel

The fireplace can be operated from the control panel, which can be accessed in the upper right corner of the insert.

⚠ IMPORTANT

These brief operation instructions are for quick reference only and should not take the place of the complete manual(s) provided by this product’s manufacturer. Refer to the corresponding links and files in Newgle for more details about your product.

POWER BUTTON

After the unit is plugged into power, press the power button to start it. Pressing it again will turn it off.

TEMP BUTTON

The temp button controls the temperature setting. The highest temperature of thermostat is 82°F. There are several levels between 62°F and 82°F, and the OFF setting.

FLAME BUTTON

The flame button controls the flame brightness. Each time the flame button is pressed, the intensity of the flame decreases. There are five brightness levels available to cycle through, as well as the OFF setting.

HEATER BUTTON

This fireplace insert consists of a fan forced electric heater with two heat settings, 750 watts or 1,500 watts. For low heat, push the temperature button once. For high heat, push the temperature button a second time.

TIMER BUTTON

Pressing the timer button will cycle through the 8 timer settings (between one and eight hours), as well as an OFF setting.

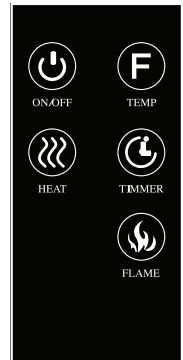

Source: 26 IN. Electric Fireplace Model #PD2616F



Microwaves and Convection Ovens

A modern convenience to keep up with even your busiest of travel days. Newmar offers a variety of microwave and convection oven choices to meet your needs and wants to make cooking quick and convenient.

With multiple cooking functions, your microwave allows you to do much more than just warming up last night’s leftovers. With the use of a combination of lights, microwaves, and convection heat, preparing entire meals is possible in a fraction of the time it takes in a conventional oven.

All microwaves and convection ovens operate on 120 Volt electricity. The control panel is a touch pad, so entering the temperature, mode, and cooking time desired is simple. A range hood may be incorporated into the microwave. The microwave’s control panel also operates the range hood functions, including the fan and light. The fan has two speeds: low and high.

Whirlpool Microwave Operation (YWMH31017FS)

This article provides basic operation instructions for a Whirlpool Microwave (YWMH31017FS).

IMPORTANT

These brief operation instructions are for quick reference only and should not take the place of the complete manual(s) provided by this product's manufacturer. Refer to the corresponding links and files in Newgle for more details about your product.

Control Panel

CLOCK

The Clock is a 12-hour (12:00-11:59) clock. Touch CLOCK, enter time, then touch CLOCK or the Start control.

TIMER

With the microwave oven in standby mode, touch the Timer control, enter time, then touch the Timer control or the Start control. Cook functions may be entered while the Timer is counting down. To cancel timer, touch Timer control while the Timer countdown is active in the display.

CONTROL LOCK

Activate to avoid unintended start. Touch and hold the Cancel control for about 3 seconds until 2 tones sound and padlock icon appears in the display. Repeat to unlock control.

VENT FAN

High ("SPd2"), low ("SPd1") and off. Comes on automatically as cooling fan during any cook function.

VENT TIMER (ON SOME MODELS):

Set vent fan to run for exactly 30 minutes, or to run for only 30 minutes more (off after 30 minutes). The vent fan may be turned off at any time using the Vent Fan control. Touch and hold number pad "4" for about 3 seconds until a tone sounds and the vent fan turns on.

TONES

Programming tones and signals. Programming tones may be turned off, or all tones (including end-of-function signals) may be turned off. To turn off programming tones, touch and hold number pad "1" for about 3 seconds, until a confirmation tone sounds. Repeat to turn back on programming tones. To turn off all tones, touch and hold number pad "2" for about 3 seconds until a confirmation tone sounds. Repeat to turn back on all tones.



DEMO MODE

Activate to practice using the control without actually turning on the magnetron. Touch and hold number pad "3" for about 3 seconds until a confirmation tone sounds, and "DEMO" icon lights up in the display. Repeat to deactivate. In Demo mode, the display and controls will work; however, the microwave will not heat.

STANDBY MODE

When no functions are working, oven will switch to standby power mode and dim the brightness after 5 minutes. Press any button or open/close the door and the display will return to the normal brightness.

TURNTABLE

For best cooking results, do not operate the microwave oven without having the turntable in place.

Settings and Features

MANUAL COOKING/STAGE COOKING

Touch COOK TIME, touch number pads to enter time, touch COOK POWER (if not 100%), touch number pads to enter power level (10-90), and then touch the Start control. If programming additional stages, enter the cook time and cook power of each before touching the Start control.

PRESET COOKING

Touch COOK, enter number code of food item, enter quantity, and then touch the Start control.

PRESET REHEATING

Touch REHEAT, enter number code of food item, enter quantity if needed, then touch the Start control.

PRESET DEFROSTING

Unwrap food. Touch DEFROST, enter number code of food item, enter weight, then touch the Start control.

SOFTEN/MELT

Touch SOFTEN/MELT, enter number code of food item, enter quantity, then touch the START control.

POPCORN

Touch POPCORN. Enter bag size in ounces: 3.0 or 3.5 (85 or 99 g), then touch START control.

(BAKED) POTATO

Touch (BAKED) POTATO. Enter number of potatoes: 1, 2, 3 or 4, about 10 to 13 oz (283 to 367 g) each, then touch START control. NOTE: Place fork-pierced potatoes around turntable edges, at least 1" (2.5 cm) apart. Place a single potato to the side of the turntable (not in the center).

PIZZA (REHEAT)

Touch PIZZA. Enter number of slices: 1, 2 or 3, about 4 oz (113 g) each, then touch START control.

Source: Whirlpool Microwave (YWMH31017FS) User Guide

Whirlpool Convection Smart Microwave Operation (WMH78019HZ)

This article provides basic operation instructions for a Whirlpool Convection Smart Microwave (WMH78019HZ).

⚠ IMPORTANT

These brief operation instructions are for quick reference only and should not take the place of the complete manual(s) provided by this product's manufacturer. Refer to the corresponding links and files in Newgle for more details about your product.

Control Panel

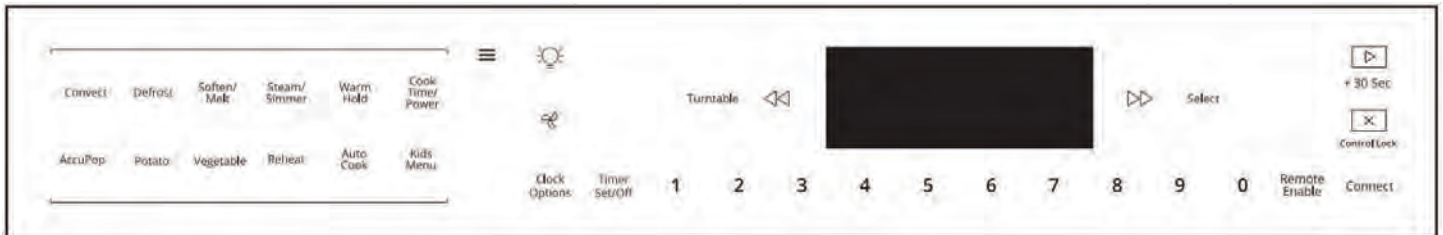

CLOCK/OPTIONS

SET THE CLOCK

1. To set the clock, for example, to 2:25 PM, touch the Menu keypad.
2. Touch CLOCK/OPTIONS.
3. Use the number keypads to enter "2:25."
4. Touch SELECT.
5. Touch "2" to display PM.

REACH OPTIONS MENU

1. Touch CLOCK/OPTIONS.
2. Use the arrow keypads to scroll through options.
3. Touch SELECT to select desired option and follow the prompts.

**LIGHT: TURN ON LIGHT**

1. Press the Light keypad to turn the light beneath the hood on or off.

**FAN: TURN ON FAN**

1. Press the Fan keypad to turn the Fan on or off. Press the fan keypad repeatedly to change from low to high.

**TIMER (SET/OFF): KITCHEN TIMER**

1. Touch TIMER SET/OFF.
2. Touch the number keypads to set the length of time. For example, to set 12 minutes length time, touch TIME SET/OFF.
3. Use the number keypads to enter "12:00."
4. Touch START.
5. If the Cancel keypad is touched, the microwave oven will turn off; however, the Timer can only be turned off using the Timer Set/Off keypad.

**START/ADD 30 SEC**

Touching the Start/Add 30 Sec keypad when the microwave oven is off will start 30 seconds of cook time at 100% power. If cooking is interrupted by opening the door, touching Start/Add 30 Sec after the door is closed again will resume the preset cycle.

NOTE: The START button displays like a PLAY button. It functions as both the START and the (+30 Sec) ADD 30 SECONDS function for this microwave. When referencing the following user instructions, "pressing the START/+30 Sec" button means pressing this "PLAY" button.

**LEFT AND RIGHT ARROWS: NAVIGATE MENU**

Press the Left or Right Arrow keypad to move through the menu.

**SELECT: OPTIONS**

Touch SELECT to select options.

**TURNTABLE: ON/OFF**

By touching the Turntable On/Off keypad, it is possible to switch the turntable on and off during some microwave cycles. The turntable can be turned on or off only during Manual cooking cycles.

**CANCEL****CANCEL COOKING FUNCTION**

Touch the Cancel keypad to cancel cooking function. The Cancel keypad stops any microwave oven function except for the Clock, Timer, and Control Lock.

The microwave oven will also turn off when the door is opened. When the door is opened, the element(s) and fan will turn off, but the microwave oven light will remain on. Close the door and touch the Start keypad to resume the preset cycle.

The microwave oven cooling fan may continue to operate even after a microwave oven function has been canceled or completed, depending on the microwave oven temperature.

**REMOTE ENABLE: ENABLE REMOTE APP CONTROL**

Remote Enable allows you to start Convection Bake cooking cycle using your mobile phone when you are away from home. Press REMOTE ENABLE to enable the ability to utilize the Whirlpool® app.

ACTIVATE CONTROL LOCK

Activate to avoid unintended start. Touch and hold the Cancel keypad for about 3 seconds until two tones sound and the Padlock icon appears in the display. Repeat to unlock control.

**CONNECT: WI-FI**

Press and hold CONNECT while your router's WPS indicator light is blinking to connect your range to your Wi-Fi network.

Cooking Options and Additional Features

MENU: TURN ON BACKLIT BUTTONS

1. Press the Menu keypad to light up the back-lit buttons.
 - Convection: Auto Convection Cooking, Manual Convection Bake, Manual Convection Roast
 - Defrost: Automatic Defrost
 - Soften/Melt: Soften, Melt
 - Steam/Simmer: Auto Steam Cook, Manual Steam Cook, Auto Simmer Cook, Manual Simmer Cook
 - Warm Hold: Keep Food Warm
 - Cook Time/Power: Manual Cooking
 - AccuPop: Popcorn (Sensor)
 - Potato: Potato (Sensor)
 - Vegetable: Vegetable
 - Reheat: Automatic Reheat
 - Auto Cook: Auto Cook
 - Kids Menu: Kids Menu



For more information about the cooking options and additional features, refer to the “Whirlpool Convection Smart Microwave (WMH78019HZ) User Instruction Manual.”

Source: Whirlpool Convection Smart Microwave (WMH78019HZ) User Instructions

Refrigerators, Freezers and Ice Makers

Offering all of the ingredients you need for a satisfying life on the road. Newmar offers many quality options for your food storage needs, all while blending beautifully with your sleek decor. With adjustable and removable shelving, your refrigerator and freezer provides you with the flexibility you need to fit your on-the-road lifestyle. Many models offer the convenience of electronic controls, a built in icemaker, and a filtered water dispenser.

Absorption-Style Refrigerator Operation Overview

This article provides basic operating instructions for an absorption-style refrigerator.

IMPORTANT

These brief operation instructions are for quick reference only and should not take the place of the complete manual(s) provided by this product’s manufacturer. Refer to the corresponding links and files in Newgle for more details about your product.

Absorption-style refrigerators are installed on select coaches. The control panel operates via 12 volts supplied by the battery/batteries. The refrigerator operates on 120 volt AC power or LP gas and heats a solution in a closed loop system. As the solution changes state and passes through the absorption stage, it cools the inside of the refrigerator and freezer box by extracting the heat and carrying it away in the solution. It does not use freon and a compressor, so this style of refrigerator takes longer to cool down.

Select models allow you to select the incoming power source of your coach, whether AC current or propane gas. All models are equipped with latches to secure the doors for a tight seal to prevent movement during transit.

Before Operation

1. Verify that the main propane gas valve is in the ON position.
2. The refrigerator is equipped with a energy control system. It can be set to either 120 Volt or propane gas operation, or set automatically select 120 volts when present and automatically change to gas when AC power is not present, if desired.
3. Verify 12 volt supply for control board operation.
4. It is recommended to pre-chill food and beverages before putting them in the refrigerator and freezer. When placing items on the racks and in the bins, leave enough space for air to flow throughout the entire refrigerator cabinet.
5. For models with a built-in ice maker, a pressurized water supply is required. In order for the ice maker to operate, you must have water in the fresh tank and have the water pump turned on, or your coach must be connected to city water supply.

How To Operate The Refrigerator In 120 Volt Mode

1. A 12 volt power supply must be available for the electronic control panel to function. The shore line must be plugged in, or the generator running, to operate in 120 volt mode.
2. To use the 2-Way Auto Mode, push the AUTO/GAS mode selector into the ON position. If 120 volt is available, the AC mode indicator light will be illuminated.

How To Operate The Refrigerator In Propane Gas Mode

1. The main propane gas valve must be open for operation in the propane mode.
2. To start the refrigerator, press the main power ON/OFF button to switch it to the ON position.
3. If 120 volt is not available, the gas mode indicator light will be illuminated. The control system will automatically switch to gas operation.
4. To operate on gas only, push the AUTO/GAS mode selector until the gas indicator light has lit. After 45 seconds the burner should be ignited and operating normally. The initial startup may take longer than 45 seconds in order to allow the air to be purged from the gas line.

For more information about the operation of the refrigerator installed in your coach see the following information that matching the manufacture and model series of your particular refrigerator.



⚠ WARNING

Most propane gas appliances used in recreational vehicles are vented to the outside of the vehicle. When parked close to a gasoline pump, it is possible that the gasoline fumes could enter this type of appliance and ignite the burner flame causing a fire or explosion. Use caution when refueling.

⚠ WARNING

Do not bring or store propane cylinders, gasoline, or other flammable liquids inside of the vehicle. Failure to comply could result in fire or explosion.

Norcold Refrigerator Operation (1200 and 1210)

This article provides basic operation instructions for a Norcold 1200 and/or 1210 Series Refrigerator.

⚠ IMPORTANT

These brief operation instructions are for quick reference only and should not take the place of the complete manual(s) provided by this product's manufacturer. Refer to the corresponding links and files in Newgle for more details about your product.

AC Operation

- 120 volts AC: 108 volts min.-132 volts max.
- 12 volts DC - control voltage: 10.5 volts min. - 15.4 volts max.

The refrigerator operates on these energy sources. Operation out of these limits can damage the refrigerator electrical components and will void the warranty.

ON/OFF BUTTON

The ON / OFF button [30] starts and shuts down the refrigerator:

1. To turn on the refrigerator, push and release the ON / OFF button.
2. To turn off the refrigerator, push the ON / OFF button for one second and then release.

Control Panel

The refrigerator control panel is between the freezer compartment and the fresh food compartment. To maintain the operating control functions of the refrigerator, a 12 volt DC power supply is necessary. The refrigerator receives DC power from the 12 volt system of the vehicle; either an auxiliary battery, a converter, or the vehicle engine battery.

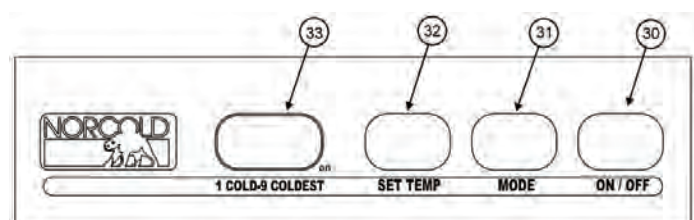

SET TEMP BUTTON

The SET TEMP button [32] controls the temperature adjustment of the freezer and the fresh food compartment.

1. Push the SET TEMP button and the temperature setting (the numbers “1-9”) show in the center display [33]. The number “9” is the coldest temperature setting.
2. Push and hold the SET TEMP button and the temperature setting changes.
3. Release the SET TEMP button when the temperature setting that you wish appears.
4. After ten seconds, the temperature setting will go out and only a green power ON light remains.

NOTE: Push and release the MODE button to show “AC”, the current mode of operation, in the center display for 10 seconds.

5. If 120 volts AC is not available to the refrigerator:
 - The fault codes “no” “AC” shows in the center display and an audible alarm sounds.
6. If 120 volts AC is available to the refrigerator, but is not operating correctly:
 - A fault code shows in the center display, and an audible alarm starts.

Optional Ice Maker

The ice maker is fully automatic and will operate in ambient temperatures as low as 0° F. To allow operation at temperatures between 0° F and 32° F., the ice maker has a heater on the solenoid water valve and on the water line between the solenoid valve and the ice maker.

When the freezer temperature of the refrigerator is low enough, the ice maker opens the water solenoid valve and fills the mold. The ice maker ejects the frozen ice into a storage bin. As the storage bin fills, the ice raises the shut-off arm until it turns off the ice maker. As you use the ice and lower the ice level in the storage bin, the shut-off arm also lowers. This turns the ice maker ON and begins the process of making ice.

The ice maker operates on:

- Cold potable water at a pressure of 15 psi - 125 psi
- 120 Volts AC: 108 VAC min. - 132 VAC max.

ICE MAKER OPERATION:

1. Make sure the ice maker AC power cord is plugged into a receptacle.
2. Open the water shut off valve of the vehicle.

NOTE: Make sure that the ice maker arm can move freely and does not touch the frozen foods in the freezer.

3. Push the ice maker arm down to the ON position.

CAUTION: If you operate the refrigerator without the proper water supply, make sure the ice maker arm is up in the OFF position.

4. Allow the freezer to cool enough and ice production will begin to fill the storage bin.

NOTE: New plumbing connections and/or impurities in the water supply line after winterizing can cause the first ice to be discolored or have an odd flavor.

5. To stop the ice maker, push the ice maker arm up to the OFF position.

Source: Norcold Owner's Manual for 1200ACXX Models

Norcold Refrigerator Operation (N10LX)

This article provides basic operation instructions for a Norcold 1200 and/or 1210 Series Refrigerator.

⚠ IMPORTANT

These brief operation instructions are for quick reference only and should not take the place of the complete manual(s) provided by this product's manufacturer. Refer to the corresponding links and files in Newgle for more details about your product.

Operating The Controls

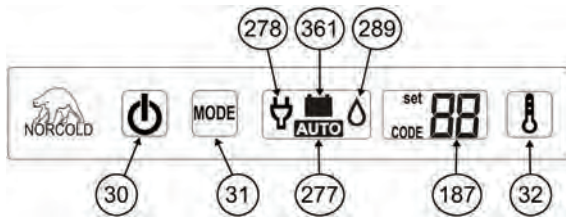

IGNITION AND START UP

- Make sure the air flow in the lower intake vent, through the refrigerator coils and condenser, and out the upper exhaust vent is not blocked or decreased.
- Make sure there are no combustible materials in or around the refrigerator.
- Make sure the DC voltage to the refrigerator is 12.0VDC

AIR IN THE PROPANE GAS SUPPLY LINES

Notice: For safety reasons, the refrigerators electronic controls are designed such that while operating in the LP GAS mode, the trial for ignition (maximum amount of the time the gas valve and igniter can be left on without a flame present) is limited to 30 seconds. When starting the refrigerator for the first time, after storage, or after replacing the propane gas tank, the propane gas supply lines can have air in them.

Due to air in the gas supply lines, the burner may not ignite within the 30 second time limit. In the event this should happen the gas valve and igniter outputs will be turned off, the LP Gas mode will be “locked out”, and the appropriate fault code will be shown in the display.

The gas lock out condition can be reset by powering the refrigerator OFF and then back ON, at which time, a new 30 second trial for ignition will commence. It may be necessary to repeat this procedure several times before expelling all the air from the LP gas supply line. If after repeated attempts, a flame is not established, stop and consult your local dealer or Authorized Norcold Service Center.

IF AN ENERGY SOURCE IS AVAILABLE TO THE REFRIGERATOR BUT IS NOT OPERATING CORRECTLY:

- While operating in the Automatic mode, the refrigerators electronic controls will automatically select the energy source using the following priority scheme:
 - 1st choice: AC Electric
 - 2nd choice: LP GAS
 - ▷ When in the Auto mode, if a higher priority choice becomes available (i.e., AC voltage reappplied), the control shall stop using the current mode and switch to the higher priority mode.

AUTOMATIC MODE OPERATION:

- Touch and release the ON/OFF button [30] to turn the refrigerator on.
- Touch the TEMP SET button [32] as needed to set the temperature setting.
 - Number one (1) shown in the display [187] is the warmest setting.
 - Number nine (9) shown in the display [187] is the coldest setting.
- If the AUTO icon [277] and AC PLUG icon [278] are lit up, it means that:
 - 120 volt AC power is available to the refrigerator.
 - The refrigerator is operating on AC electric power.
 - After ten seconds, the backlight of the display goes off.
- If the AUTO icon and the FLAME icon [289] are lit up, it means that:
 - 120 volt AC power is not available to the refrigerator.
 - The refrigerator is operating on propane gas.
 - After ten seconds, the backlight of the display goes off.

IF NEITHER 120 VOLTS AC NOR PROPANE GAS ARE AVAILABLE TO THE REFRIGERATOR:

- 2-way refrigerators:
 - The fault codes “no AC” and then “no FL” show in the display and an audible alarm sounds.
 - Refer to the “Fault Codes” section of the refrigerator’s manual for any faults displayed.
- 3-way refrigerators only:
 - The Auto icon and the Battery icon [361] are lit up.
 - After ten seconds, the backlight of the display goes off.
 - This means that the refrigerator is operating on DC electric.

MANUAL AC MODE OPERATION:

- Touch and release the ON/OFF button [30] to start the refrigerator.
- Touch the MODE button [31] until the AUTO icon goes off and only the AC PLUG icon [278] remains lit.
- Touch the TEMP SET button [32] as needed, to set the temperature setting.
- The AC PLUG icon [278] remains lit until you select a different operating mode or shut down the refrigerator.

MANUAL LP GAS OPERATION:

- Touch and release the ON/OFF button [30] to start the refrigerator.
- Touch the MODE button [31] until the AUTO icon goes off and only the FLAME icon [289] remains lit.
- Touch the TEMP SET button [32] as needed, to set the temperature setting.
- The FLAME icon [278] remains lit until you select a different operating mode or shut down the refrigerator.

SHUT DOWN - ALL MODELS:

- To shut down the refrigerator, touch and hold the ON/OFF button [30] for two seconds and release.

Source: Norcold Owner's Manual for Polar 10 Series (N10LX and NA10LX models) Refrigerators

Residential-Style Refrigerator Operation Overview

This article provides a general overview of how a residential-style refrigerator operates.

Residential-style refrigerators are the most popular option installed in Newmar coaches. The refrigerator operates on 120 volt AC power and uses freon and a compressor to keep your food cold and fresh. The power may be supplied by the electrical hookup at the campsite, generator power or (in most coaches) an inverter with a charged house battery bank.

⚠ IMPORTANT

These brief operation instructions are for quick reference only and should not take the place of the complete manual(s) provided by this product's manufacturer. Refer to the corresponding links and files in Newgle for more details about your product.

For models with a built-in ice maker, a pressurized water supply is required. In order for the ice maker to operate, you must have water in the fresh tank and have the water pump turned on, or your coach must be connected to city water supply.

When placing items on the racks and in the bins, leave enough space for air to flow throughout the entire refrigerator cabinet.

All models are equipped with a means to latch and secure the doors for a tight seal and to prevent the doors from opening during transit. Become familiar with the latch operation and always lock prior to traveling.

Pummell Drive Mini Refrigerator Operation (PD17BL-NF / BC-46E-NF)

This article provides basic operation instructions for a Pummell Drive Mini Refrigerator (PD17BL-NF / BC-46E-NF).

⚠ IMPORTANT

These brief operation instructions are for quick reference only and should not take the place of the complete manual(s) provided by this product's manufacturer. Refer to the corresponding links and files in Newgle for more details about your product.

Operation

STARTING YOUR NEW REFRIGERATOR

1. Clean the refrigerator thoroughly. Wipe the outside with a soft, dry cloth and the interior with a clean, moist cloth.
2. Insert the power supply cord into the socket (if it was removed).
3. Adjust the temperature control knob to "7" and run for two to five hours to ensure the cabinet is thoroughly chilled prior to adding food.
4. Reset the temperature control knob to the normal recommended setting ("4"), and add pre-chilled food and/or drinks.

TEMPERATURE CONTROL

- Your refrigerator has one control for regulating the temperature. The temperature control knob is located in the refrigerator.
- The range of the refrigerator temperature control is from position “1” (the warmest) to “7” (the coldest). Adjust the temperature control to the setting that best suits your needs. The setting of “4” should be appropriate for home refrigerator use.
- To turn off the refrigerator, please turn the temperature control knob to “0.” Please note that turning the temperature control knob to “0” will stop the cooling cycle, but does not disconnect the power supply to the refrigerator.

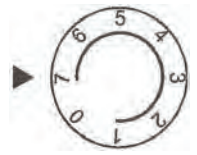

Whirlpool Refrigerator Operation (WRT111SFDM)

This article provides basic operation instructions for a Whirlpool Refrigerator (WRT111SFDM).

IMPORTANT

These brief operation instructions are for quick reference only and should not take the place of the complete manual(s) provided by this product’s manufacturer. Refer to the corresponding links and files in Newgle for more details about your product.

Using The Controls

TEMPERATURE CONTROL

When you plug in the refrigerator for the first time, set the Temperature Control to the Recommended setting. Temperature Control adjustments range from MIN (least cold) to MAX (coldest).



IMPORTANT:

- Turning the Temperature Control to OFF stops cooling in the refrigerator and freezer compartments, but it does not disconnect the refrigerator from the power supply.
- The Temperature Control regulates the temperature in both the refrigerator and freezer compartments. Settings to the left of the mid-setting make the temperature less cold. Settings to the right of the mid-setting make the temperature colder.
- Wait 24 hours before you put food into your refrigerator. If you add food before the refrigerator has cooled completely, your food may spoil.

NOTE: Adjusting the Temperature Control to a higher (colder) setting will not cool the compartments any faster.

- The mid-settings should be correct for normal household usage. The controls are set correctly when milk or juice is as cold as you like and when ice cream is firm.
- If the temperature is too warm or too cold in the refrigerator or freezer, before adjusting the controls, first make sure the air vents are not blocked.

ADJUST THE TEMPERATURE CONTROL

NOTE: Wait at least 24 hours between adjustments and then recheck the temperatures.

Condition/Reason	Adjustment
Refrigerator too warm	Temperature Control one setting higher
Freezer too warm/too little ice	Temperature Control one setting higher
Refrigerator too cold	Temperature Control one setting lower
Freezer too cold	Temperature Control one setting lower

AIRFLOW CONTROL

The Airflow control is located on the back wall of the freezer. It regulates the amount of air flowing between the freezer and the refrigerator compartments. When you plug in the refrigerator for the first time, turn the Airflow control to the Recommended setting.

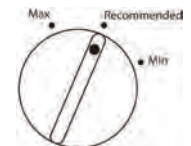

ADJUST THE AIRFLOW CONTROL

If you want to temporarily increase the cold airflow to a specific compartment, adjust the control.

IMPORTANT: Once the performance is achieved, return the Airflow control to the Recommended setting to keep the refrigerator operating at optimum efficiency.

Condition/Reason	Adjustment
Heavy ice use	Max
Hot room temperature	Max - To maintain ice making production rate
Large quantity of groceries	Min - To quickly chill food and beverages

CRISPER HUMIDITY CONTROL (ON SOME MODELS)

You control the amount of humidity in the moisture-sealed crisper. Depending on the produce you are storing, select the desired Humidity Level.

HUMIDITY LEVEL - MIN SETTING

MIN (open) lets moist air out of the crisper for best storage of fruits and vegetables with skins.

- Fruit: Wash, let dry and store in refrigerator in plastic bag or crisper. Do not wash or hull berries until they are ready to use. Sort and keep berries in original container in crisper, or store in a loosely closed paper bag on a refrigerator shelf.
- Vegetables with skins: Place in plastic bag or plastic container and store in crisper.



MAX (closed) keeps moist air in the crisper for best storage of fresh, leafy vegetables.

- Leafy vegetables: Wash in cold water, drain and trim or tear off bruised and discolored areas. Place in plastic bag or plastic container and store in crisper.

Ice Maker (On Some Models)

TURNING THE ICE MAKER ON/OFF

NOTE: Do not force the wire shutoff arm up or down.

- To turn the ice maker on, simply lower the wire shutoff arm.

NOTE: Your ice maker has an automatic shutoff. As ice is made, the ice cubes will fill the ice storage bin and the ice cubes will raise the wire shutoff arm to the OFF (arm up) position.

- To manually turn off the ice maker, lift the wire shutoff arm to the OFF (arm up) position and listen for the click to make sure the ice maker will not continue to operate.

NOTE: Turn off the ice maker before removing the ice storage bin to serve ice or to clean the bin. This will keep the ice cubes from dropping out of the ice maker and into the freezer compartment. After replacing the ice storage bin, turn on the ice maker.



ICE PRODUCTION RATE

In normal operation, the ice maker should produce approximately 8 to 12 batches of ice in a 24-hour period. If ice is not being made fast, enough adjust the controls.

- Air Flow Control - Turn the control dial to the Max Freezer setting.
- Temperature Control - Turn the control dial gradually toward the Max setting, waiting 24 hours between each increase.

REMEMBER:

- Allow 24 hours to produce the first batch of ice. Allow 3 days to completely fill the ice storage bin. Discard the first three batches of ice produced.
- The quality of your ice will be only as good as the quality of the water supplied to your ice maker. Avoid connecting the ice maker to a softened water supply. Water softener chemicals (such as salt) can damage parts of the ice maker and lead to poor quality ice. If a softened water supply cannot be avoided, make sure the water softener is operating properly and is well maintained.
- Do not store anything on top of the ice maker or in the ice storage bin.

Source: Whirlpool Refrigerator User Instructions (WRT11SFDM)



Washer and Dryer Overview

Depending on your model, year, and available options, your coach may be equipped with a stackable washer and dryer, or an all-in-one laundry center located in a cabinet. They are built for life on the road, so they are compact to save space, weight, and resources, without sacrificing performance. Some coach floorplans may also provide the option for washer and dryer hookups, in lieu of the appliances.

Operation

The plumbing and other preparations for the installation of a compact washer and dryer are optional features on your coach. The washers and dryers function like those in a home. Most operate on 120 volt electricity; however, some dryers may require 240 volt electricity.

Washer and Dryer Prep

If a washer and dryer unit is not installed in your coach, it may be prepped at the factory so that a unit can be added later. Units not ordered and/or installed by the factory will not be covered by Newmar's warranty.

P-TRAPS

Each of the sink drains, the shower drain, and the washing machine drain (if equipped) has a water trap to prevent holding tank odors from entering the coach. These traps must have water in them in order to trap the odors. While stored, the water may evaporate, allowing an odor to enter the coach. If this occurs, run water from the faucet into the drain, allowing water to fill the trap. Run water into the washing machine. Set the cycle to spin to drain the water to fill the p-trap.

Splendide Washer Operation (ARWXF129WNA)

This article provides basic operation instructions for a Splendide Washer (ARWXF129WNA).

Control Panel

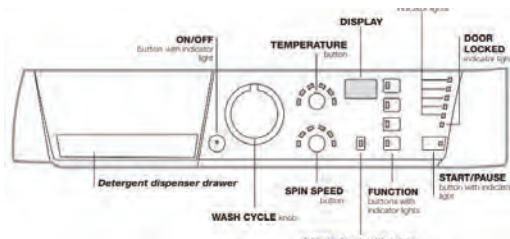

DETERGENT DISPENSER DRAWER

Used to dispense detergents and washing additives

ON/OFF BUTTON

ON/OFF button with indicator light: switches the machine on and off. If the indicator light is illuminated, this indicates that the machine is switched on.

WASH CYCLE KNOB

Programs the wash cycles. During the wash cycle, the knob does not move.

SPIN SPEED BUTTON

Sets the spin speed or exclude the spin cycle completely.

TEMPERATURE BUTTON

Sets the temperature or the cold wash cycle. The wash temperatures selections are uniformly distributed.



WARNING

Do not operate the dryer without opening a window or outside vent to provide outside air. Failure to comply may cause asphyxiation which could result in death or serious injury.

CS-91

NOTICE

Remove outside drain cap before operating washing machine.

NI-12

IMPORTANT

The gray tank valve must be in the 'open' position when operating the washing machine.

IMPORTANT

These brief operation instructions are for quick reference only and should not take the place of the complete manual(s) provided by this product's manufacturer. Refer to the corresponding links and files in Newgle for more details about your product.

DISPLAY

Indicates the time remaining for the selected wash cycle and, if a delayed start has been programmed, the time remaining until the start of the wash cycle.

CONTROL PANEL LOCK BUTTON WITH INDICATOR LIGHT

Activates or deactivates the control panel lock.

FUNCTION BUTTONS WITH INDICATOR LIGHT

Used to select the available functions. The indicator light corresponding to the selected function will remain lit.

WASH CYCLE PROGRESS INDICATOR LIGHTS

Used to monitor the progress of the wash cycle. The illuminated indicator light shows which phase is in progress.

DOOR LOCKED INDICATOR LIGHT

Indicates whether the door may be opened or not.

START/PAUSE BUTTON WITH INDICATOR LIGHT

Starts or temporarily interrupts the wash cycles.

Indicator Lights

The indicator lights provide important information. This is what they can tell you:

WASH CYCLE PHASE INDICATOR LIGHTS

As the WASH CYCLE knob is rotated, the indicator lights illuminate, indicating the stages which will be performed by the machine in accordance with the selected wash cycle. Once the desired wash cycle has been selected and has begun, the indicator lights switch on one by one to indicate which phase of the cycle is currently in progress.



FUNCTION BUTTONS AND CORRESPONDING INDICATOR LIGHTS

When a function is selected, the corresponding indicator light will illuminate. If the selected function is not compatible with the programmed wash cycle, the corresponding indicator light will flash, a sound signal will be emitted and the function will not be activated.

If a function which is incompatible with another function selected previously, only the most recent selection will remain active.

Starting A Wash Cycle

1. Switch the washing machine on by pressing the ON/OFF button. All indicator lights will switch on for a few seconds, then they will switch off and the START/PAUSE indicator light will pulse.
2. Load the laundry and close the door.
3. Set the WASH CYCLE knob to the desired programme.
4. Set the washing temperature.
5. Set the spin speed.
6. Measure out the detergent and washing additives.
7. Select the desired functions.
8. Start the wash cycle by pressing the START/PAUSE button and the corresponding indicator light will remain lit in a fixed manner, in green. To cancel the set wash cycle, pause the machine by pressing the START/PAUSE button and select a new cycle.
9. At the end of the wash cycle the (END) indicator light will switch on. The DOOR LOCKED indicator light will switch off, indicating that the door may be opened. Take out your laundry and leave the appliance door ajar to make sure the drum dries completely. Switch the washing machine off by pressing the ON/OFF button.

NOTE: To pause the wash cycle in progress, press this button; the corresponding indicator light will flash orange, while the indicator light for the current wash cycle phase will remain lit in a fixed manner. If the DOOR LOCKED indicator light is switched off, the door may be opened. To start the wash cycle from the point at which it was interrupted, press this button again.

TEMPERATURE INDICATOR LIGHT

When a temperature value is selected, the corresponding indicator light will illuminate.

SPIN INDICATOR LIGHT

When a spin value is selected, the corresponding indicator light will illuminate.

CONTROL PANEL LOCK INDICATOR LIGHT

To activate the control panel lock, press and hold the button for approximately 2 seconds. When the indicator light is illuminated, the control panel is locked. This means it is possible to prevent wash cycles from being modified accidentally, especially where there are children in the home.

To deactivate the control panel lock, press and hold the button for approximately 2 seconds.

DOOR LOCKED INDICATOR LIGHT

If this indicator light is on, the appliance door is locked to prevent it from being opened accidentally; to avoid any damage, wait for the indicator light to switch off before you open the appliance door.

NOTE: If the DELAY TIMER function is activated, the door cannot be opened; pause the machine by pressing the START/PAUSE button if you wish to open it.

If the START/PAUSE indicator light (orange) flashes rapidly at the same time as the function indicator light, this indicates a problem has occurred.

Source: Splendide Washing Machine Instructions for Use (ARWXF129W)

Splendide Dryer Operation (TVM63X)

This article provides basic operation instructions for a Splendide Dryer (TVM63X).

IMPORTANT

These brief operation instructions are for quick reference only and should not take the place of the complete manual(s) provided by this product's manufacturer. Refer to the corresponding links and files in Newgle for more details about your product.

Control Panel

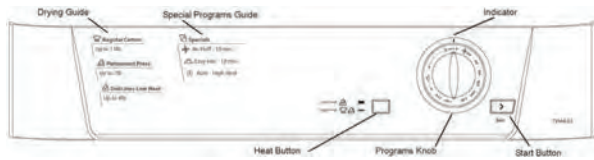

START BUTTON

The START button begins drying a selected program.

HEAT BUTTON

The HEAT button selects drying temperature.

- In HIGH heat.
- Out: LOW heat.

DRYING GUIDE

The Drying Guide allows you to consult a user friendly table of fabric types and load capacities.

SPECIAL PROGRAMS GUIDE

The Special Programs Guide gives a guide to the available programs.

PROGRAMS KNOB

The PROGRAMS knob sets the program: rotate it clockwise, never counter-clockwise, until the indicator is pointing to the program you want to select. The program knob will advance to the 0 position after the program ends.

Start and Programs

CHOOSING A PROGRAM

1. Plug the dryer into the electrical socket.
2. Sort your laundry according to fabric type.
3. Open the door and make sure the filter is clean and in place.
4. Load the machine and make sure that the items are not in the way of the door seal. Close the door.
5. Choose a drying program by checking the Programs table as well as the indications for each type of fabric.
 - set temperature with the HEAT button;
 - select a program or drying time by rotating the PROGRAM knob clockwise.
6. Press the START button to begin. During the drying program, you can check on your laundry and take out the items that are dry while the others continue drying. When you close the door again, press START in order to resume drying.
7. About 10 minutes before the program is completed, it enters the final AIR FLUFF phase (fabrics are cooled), which should always be allowed to complete.
8. Open the door, take your laundry out, clean the filter and replace it.
9. Unplug the dryer.

Source: *Splendide Tumble Dryer Care, Use, and Installation Booklet*



CHASSIS

From the Chassis on up, Newmar coaches are built to be dependable, durable, comfortable, and beautiful. Built specifically for Newmar with the highest quality in handling, safety, performance, and dependability.

Newmar starts with an innovative chassis weld process to ensure that your coach drives with less noise, a smoother ride, and has a longer service life. After the chassis is leveled and squared, it is painstakingly integrated into the rest of the structure for strength and integrity. Sub-floor structures are welded to the chassis rail and are insulated for easy climate control.

IMPORTANT

For all driver-related controls and gauges, lighting, brakes, tires and wheels, and towing information, please refer to your chassis owner's manual.



Ford

The specific information for your chassis is provided by Ford and covers many topics including general maintenance, engine information, capacities, tire information, and driver tips.

This article provides contact information for Ford, including phone, web address, and mailing address.

Roadside Assistance

- Phone: 800.392.3673
- Web: <http://owner.ford.com/contact-us.html>
- Mail: Ford Motor Company | Customer Relationship Center | P.O. Box 6248 | Dearborn, MI 48126

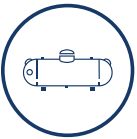

Fuel Systems

This section provides information about the fuel systems in your coach, including LP (if equipped), chassis engine fuel, and auxiliary fuel tanks (if equipped).

Chassis Gas Engine Fuel

This article provides information regarding the chassis gas engine fuel, as well as some labels that may appear on the inside or outside of the coach.

Below are sample labels that might appear on the inside or outside of your coach.

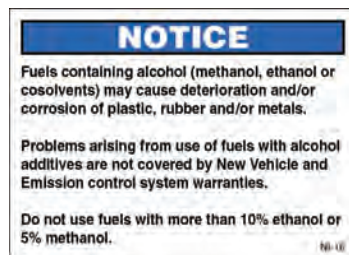

IMPORTANT

Consult your chassis manufacturer information about your recommended fuel and fuel blends, additives, and maintenance requirements.



Leveling Systems

WARNING

Never operate any leveling system with a person or pet under the unit. Serious injury or death may result!

⚠ WARNING

Do not lift the wheels off of the ground while leveling the coach. The vehicle may drop and/or move forward or backward without warning, which may cause serious injury or death.

⚠ WARNING

Never attempt to move the unit with the leveling jacks deployed. Always visually inspect the jacks prior to moving to ensure they are fully retracted, are in the stored position, and the system is turned OFF.

⚠ WARNING

Be sure the ground on which you are parked will support the weight of your unit. Often material that seems “safe” to level on will not support the weight at the leveling jack points. Use caution when leveling on hot asphalt, sand, and grass, as the weight of the unit may cause the jacks to sink into the ground. Pads may need to be placed under the jacks to spread the weight over a larger area. Always look under your unit prior to leveling to make sure the jacks are clear of debris and other foreign materials that may interfere with leveling.

Care and Maintenance

⚠ IMPORTANT

The leveling system should be cycled at least once a month to keep the system in operating condition.

Extending and Retracting The Slideouts

This article provides step-by-step instructions for leveling the coach and operating the slideouts.

Before Extending The Slideouts

1. Park the coach on a reasonably level campsite.
2. Leave the coach at ride-height with air in the air bags (if equipped with air suspension) or on normal suspension (coaches without air suspension).
3. Plug the coach into shore power (if available) or start the generator to increase the voltage for better slideout operation.
4. For a full wall slideout, visually inspect the front vertical trim for adequate clearance. The spacing should look even from top to bottom. (See image.)
5. Verify that the path of the slideout is unobstructed and free from any surrounding objects, both inside and outside of the coach.
6. Once the appropriate conditions are met, follow the operating instructions posted in your coach to extend the slideouts.
7. Deploy the leveling jacks.

⚠ IMPORTANT

In the unlikely occasion that the slideout trim has inadequate clearances, try leveling or repositioning the coach and rechecking the clearances before extending the slideout.

Before Retracting The Slideouts

1. Retract the leveling jacks.
2. Start the coach.
3. Allow the coach air suspension to fill and return to ride height (units without air suspension will return to normal suspension).
4. Turn the engine off.
5. For a full wall slideout, visually inspect the front vertical trim for adequate clearance. The spacing should look even from top to bottom. (See image for reference.)
6. Verify that the path of the slideout is unobstructed and free from any surrounding objects, both inside and outside of the coach. This includes any water or debris that may have collected on the slideout roof or the topper awning.



7. Retract the slideouts.
8. Inspect all slideouts for complete retraction.
9. If the coach is equipped with manual lock arms, make sure to lock them.
10. Unplug the coach from shore power when you are ready to depart.

IMPORTANT

Debris left on the roof or topper may prevent the slideout from sealing properly when retracted, as well as prevent the mechanical lock arms from closing properly when the slideout is extended.

IMPORTANT

In the unlikely occasion that the slideout trim has inadequate clearances, try leveling or repositioning the coach and rechecking the clearances before retracting the slideout.

How to Operate the Equalizer Leveling System

This article provides the step-by-step instructions for operating an Equalizer leveling system.

This sequential leveling is a patented process that provides a more precise level throughout the length of the vehicle, adding stability to the vehicle while leveling it as low to the ground as possible. It's quick, easy, and on the level!

WARNING

Read the Operation Manual for your specific leveling system, and follow all safety warnings and notices.

IMPORTANT

These brief operation instructions are for quick reference only. Any quick start instructions provided should not take the place of the complete Operation Manual provided by this item's manufacturer.

Auto-Level Operation

POWER ON

Press and release the POWER button to engage power. All LED's on the panel will come on then most will go out. The LED next to the POWER button should be lit RED when power is on.

EXTEND

To extend the jacks the ignition key must be in the engine run or on position and the park brake must be applied. To retract the ignition key must be in the engine run or on position. If you attempt Auto-Level or All Retract you will hear a "deni" tone if the key or park brake is in the improper position.

AUTO-LEVEL

Press the AUTO-LEVEL button and release. The system will send out a continuous series of beeps, the 'OPERATING' LED will be on RED to let you know AUTO-LEVEL is operating and will automatically level the coach. When completed, the keypad will signal a successful level with a dual-level tone. Press and release the POWER button.

RETRACTING THE JACKS

HELPFUL HINT: If your coach is equipped with air suspension, it is recommended that the coach be started and chassis air pressure allowed to build before pressing ALL RETRACT. This will ensure adequate air supply to the chassis air valves.

To retract all jacks simultaneously, press and release the All RETRACT button. All jacks will automatically retract and return to stowed position. The pump will run in retract mode until all of the jacks are fully stowed (plus an additional 5 seconds) up to a maximum of 60 or 90 seconds). This is the proper method for retracting the jacks prior to travel.

The jacks down LED's will turn off, indicating the jacks are in the "stowed" position.

NOTICE

The keypad may be left on once level has been achieved. The keypad will enter 'sleep mode' after five minutes of inactivity.

IMPORTANT

The jacks down LED lights must be off for Auto-Level to function. If needed, press the ALL RETRACT button to clear and then Auto-Level should function.

POWER OFF

Press and release the Power keypad button.

⚠ IMPORTANT
Visually confirm all jacks are retracted prior to travel.

Manual Operation

POWER ON

Press and release the POWER keypad button to engage power. All LED's will come on then most will go out. The LED next to the POWER button should be lit RED when power is on.

EXTENDING JACKS MANUALLY

To extend the jacks the ignition key must be in the engine run or on position and the park brake must be applied. If you attempt to extend or retract jacks by pressing the DOWN▼ or UP▲ keypad buttons you will hear a “deny” tone from the keypad if the ignition key and or park brake is in the improper position.

PLANTING THE JACKS

The jacks will be extended in pairs Fronts or Rears or Left or Right Using the DOWN▼ (extend) keypad buttons, extend the jacks until they contact the ground (this is referred to as “planting” the jacks). As you extend each pair of jacks the corresponding LED jack status lights will come on to indicate jack(s) are out of the “stowed” position.

⚠ NOTICE
Jacks will be operated in pairs.

⚠ WARNING
Do not manually over extend jacks. This may cause unwanted stress on the coach or the jacks.

⚠ WARNING
Do not attempt to lift the vehicle tires off of the ground. Only lift (extend) enough to level and stabilize the unit.

LEVELING THE COACH

Use a bubble level on a flat surface in the center of the coach as a reference. Level the vehicle by using DOWN▼ (extend) or UP▲ (retract) keypad buttons until the vehicle is level. Front to rear then side to side.

Once level, press and release the POWER button to turn off the keypad.

⚠ NOTICE
The keypad may be left on once level has been achieved. The keypad will enter ‘sleep mode’ after five minutes of inactivity.

RETRACTING THE JACKS

HELPFUL HINT: If your coach is equipped with air suspension, it is recommended that the coach be started and chassis air pressure allowed to build before pressing ALL RETRACT. This will ensure adequate air supply to the chassis air valves.

To retract the jacks the key must be in the engine run or on position and the park brake must be applied. To retract all jacks simultaneously, press and release the ALL RETRACT button. All jacks will automatically retract and return to stowed position. The pump will run in retract mode until all of the jacks are fully stowed (plus an additional 5 seconds- up to a maximum of 60 or 90 seconds). This is the proper method for retracting the jacks prior to travel.

You may stop the ALL RETRACT by pressing any button on the keypad. Jacks may be retracted in pairs by using the UP▲ button for each end or side for leveling purposes. However, the ALL RETRACT must be used to fully stow the jacks prior to travel. The jacks down status LED lights will turn off, indicating the jacks are in the stowed position.

POWER OFF

Press and release the Power keypad button.

⚠ IMPORTANT
Visually confirm all jacks are retracted prior to travel.

Fluid Level Maintenance

The hydraulic leveling system was filled with Dexron/Mercon transmission fluid during production. Periodically check the fluid levels in the leveling system. The reservoir level should remain at 3/4 full when the jacks are retracted. Add fluid as needed. Change the fluid if debris or water enters the reservoir.



Wheels and Tires

Wheels and Tires Size and D.O.T. Code

This article provides basic information about the wheels and tires, including the tire size, inflation, and D.O.T. codes.

Newmar's quality extends to every inch of your coach, right down to the tires and wheels. The durability and longevity of your tires will provide you with the confidence and peace of mind you need to relax and enjoy the ride.

The primary areas of concern are the tire size, inflation, and operational information. The sidewall of the tire contains detailed information about the construction, inflation, and carrying capacity of the tire. Become familiar with this information, and operate the vehicle within the capacity parameters outlined.

Tire Size

The sidewall of the tire contains information that is important to know to ensure proper use of the tire, as well as to maintain long life. Take the time to become familiar with the size, load rating, and pressure information listed on the sidewalls of the tires.

This tire size is 315 / 80 R 22.5. From this size, we can determine the physical dimensions of the tire, as well as its basic construction. The tire size breaks down like this:

- The first number, "315", is the section width of the tire in millimeters. The section width is the measurement of the tire from the outside sidewall to the inside sidewall.
- The second number is the height of the sidewall, expressed as a percentage of the section width. In this case, the number is "80", so the sidewall height accounts for 80 percent of the tire's section width.
- The "R" in the tire size indicates that this tire is "radial" in construction. The belts are wrapped around the tire in a radial design, from bead to bead.
- The final number is "22.5", which is the rim size the tire was designed to fit. This tire fits a 22.5" diameter wheel.



D.O.T. Code

The last four digits on tires manufactured after the year 2000 signify the week and year of manufacture.

The tire in the example picture was made during the 29th week of 2017.



Tire Care and Maintenance

This article provides information about the care and maintenance of your coach tires, including examples of labels and tire pressure charts. To ensure your tires are operating safely, regularly inspecting your tires and checking your tire pressure is absolutely mandatory.

Tire pressures should be checked and adjusted before and after each trip. Always check and adjust the pressures while the tires are cold. Never add or release pressure from the tires when they are hot (after having driven a mile or more).

For safe operation and maximum weight carrying capacity, it is imperative that the tires be inflated to and maintained at the listed tire pressures on the Federal ID Tag. This tag is affixed to the interior wall just behind the driver's seat in your coach.

WARNING

Proper tire maintenance is critical to the safety, operation, and durability of your coach. Failure to follow and monitor tire pressure guidelines may result in premature tire failure.

NOTICE! **CHECK WHEEL LUGS**

On first trip, tighten wheel lugs at start and at 10, 25 and 50 miles. Tighten to manufacturer's specifications.

Thereafter, check wheel lugs before each trip, after excessive braking and following winter storage.

AD-24

If you are operating your coach while staying significantly under the maximum weight carrying capacity, you may experience an unnecessarily firm ride. To correct this condition, it is recommended for you to weigh the coach when it is fully loaded as you would travel, with full fuel, water, and LP tanks, all travelers, and your belongings, as well as any towed equipment. Weigh each axle end separately, and use the heaviest end weight to determine the axle's cold inflation tire pressure.

For units operating significantly under maximum weight carrying capacity experiencing an unnecessarily firm ride. We recommend for you to weigh the coach loaded as you will be traveling with fuel, water, Lp, belongings, persons and weight of towed equipment, weighing each axle end separately and using the heaviest end weight to determine the axle's cold inflation tire pressure use the inflation chart provided by the tire manufacture for you specific brand, series,& size and load range of tire use the dual and single weight charts according to the tire configuration you are inflating.

Make sure tire pressures are the same across an axle, while NEVER exceeding the maximum air pressure limit stamped on the wheels or tires nor under inflating a tire below the lowest pressure on the tires inflation chart. For more detailed information refer to the tire inflation pressure article in Newgle.

Use the inflation chart provided by your specific tire manufacturer according to brand, series, size, and load range. Also, pay attention to the chart when referring to dual or single tire configurations, as they will change based upon which tire you are inflating.

295/60R22.5 J												
	PSI	85	90	95	100	105	110	115	120	125	130	
	kPa	590	620	660	690	720	760	790	830	860	900	Maximum load & pressure on sidewall
LBS	Single	5200	5505	5750	5990	6230	6465	6700	6930	7160	7390	S 7390 LBS at 130 PSI
	Dual	9650	10100	10550	10990	11430	11860	12290	12720	13140	13560	D 6780 LBS at 130 PSI
KG	Single	2385	2495	2610	2715	2825	2930	3040	3145	3230	3350	S 3350 KG at 900 kPa
	Dual	4375	4580	4785	4985	5185	5380	5575	5770	5960	6150	D 3075 KG at 900 kPa

Example of a Tire Inflation Chart

⚠ WARNING

Failure to follow proper inflation guidelines may result in tire failure, which can cause loss of vehicle control or accidents resulting in property damage, bodily injury, or death.

⚠ IMPORTANT

The tire pressure settings can change depending on whether they are used in single or dual tire situations.

⚠ IMPORTANT

Make sure the tire pressures are the same across an axle, while never exceeding the maximum air pressure limit stamped on the wheels or tires, or leaving a tire below the minimum pressure listed on your tire inflation chart.

⚠ IMPORTANT

Do not use the example to find your recommended tire pressures. Refer to your tire manufacturer's owner's manual and specific tire inflation guidelines.

⚠ NOTICE

Exact tire inflation charts will not be provided by Newmar. Each tire manufacturer provides this information, as it changes by brand, make, tire series, tire size, as well as if it is used in a single or dual setup. For more information about your tires and the inflation specifications, please refer to the Item Home Page of your tire manufacturer.

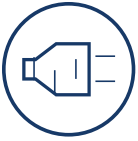

ELECTRICAL

WARNING

Due to the risk of electrical shock, service should be performed by a qualified electrician or authorized service technician. The electrical system may have multiple 120/240 volt power sources. All power sources must be turned off, and any auto generator start features must be disabled prior to servicing.



12 Volt Electrical System

This article provides general information about the components and functions of the 12 Volt Electrical System (DC) in Newmar coaches.

Power Sources

The 12 Volt Electrical System allows certain components to maintain a low voltage from the battery bank. The battery bank is controlled by the coach charging system, which consists of a charge bridge solenoid, a bi-directional isolator relay delay (BIRD), or a battery isolation manager (BIM). When the coach engine is running, the alternator charges the chassis batteries and may assist in charging the house batteries through the BIM, BIRD, or Charge Bridge.

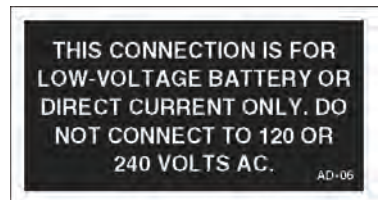

When the coach is connected to shore power or when the coach generator is in use (when shore power is unavailable), the converter or inverter/converter combination recharges the house batteries, and with the assistance of a BIM, BIRD, or Charge Bridge, it can also charge the chassis batteries.

In addition to the alternator and converter, the coach may also be equipped with solar panels to provide an additional option for charging your house batteries.

ALTERNATOR

The alternator is a belt-driven component attached to the coach engine and is supplied by the chassis manufacturer. The alternator supplies power for chassis components such as batteries, lights, wipers, dash HVAC, and power seats, as well as all of the driver controls located in the cockpit. The alternator charges the chassis batteries, but with the addition of a BIM, BIRD, or Charge Bridge, it may also assist in charging the coach's house batteries.

GENERATOR

When shore power is unavailable, the generator takes mechanical energy and converts it into alternating current to supply 120 volts to the coach and charge the coach's house via the converter or inverter/converter and the chassis batteries via BIRD, BIM, or charge bridge.

The generator is typically located in the front of the unit between the frame rails on diesel coaches. On gas units, the generator may be located anywhere between the mid and rear section of the coach. Generators can be powered by gas, liquid propane, or diesel fuel.

CONVERTER AND INVERTER/CONVERTER COMBINATION

All Newmar coaches are equipped with a converter or inverter/converter combination. A converter transforms alternating current or shore line power 120 Volts to low-voltage direct current to provide power to the coach's 12 Volt house and chassis batteries. On the other hand, an inverter transforms direct current to alternating current to provide power to specified appliances and entertainment systems.

SOLAR PANEL

Some Newmar units are equipped with a 10 Watt solar panel wired to the chassis batteries. Prior models may have a five or 10 Watt solar panel and may be wired to the chassis-side KIB panel.

BATTERIES

Please refer to the Battery Basics article for more information.

Power Distribution

BATTERY DISCONNECT

Newmar uses an Intellitec disconnect relay connected to the battery bank to disconnect certain loads when placing the coach in storage. Keep in mind that not all loads are disconnected. This is very important to remember when a coach is put into storage and is not plugged into shore power. Before placing the battery disconnect in the “off” position, make sure the inverter (if equipped) is turned off.

When an older coach is stored while plugged into shore power, do not use the battery disconnect. If the battery disconnect is used, the chassis batteries will not receive a charge from the converter or inverter/converter combination. This is due to the coach battery wire being disconnected, meaning the BIM or the BIRD will not engage.

Some coach models have a manual rotary key switch to disconnect power, which is located in the overhead above the entry door. Most other coaches have a single lighted switch located in the front overhead that turns off the house voltage.



⚠ IMPORTANT

When the battery disconnect is ‘off’, meaning you have disconnected components from the batteries, there are still some loads on the batteries connected to the hot side of the Battery Disconnect Relay. Some of these loads may be Radio Memory, Entry Steps, and LP Detector. These will draw from the batteries, even when the disconnect is ‘off’. Pull the fuse for each of the ‘HOT’ circuits to stop the batteries from being drained.

To learn more, visit the Battery Disconnect home page in Newgle.

BI-DIRECTIONAL ISOLATOR RELAY DELAY (BIRD)

Current gas coaches and some older diesel coaches, use an Intellitec Bi-Directional Isolator Relay Delay (BIRD) with a separate solenoid. The BIRD monitors both the chassis and house battery and is the only place in the coach where they both merge. The BIRD only functions when the engine or generator is running or when the coach is connected to shore power.

To learn more, visit the Bi-Directional Isolator Relay Delay home page in Newgle.



BATTERY ISOLATION MANAGER (BIM)

All current Dutch Star, Ventana, and Ventana LE diesel coaches use a Precision Circuits all-in-one Battery Isolation Manager (BIM). The BIM monitors both the chassis and house battery and is the only place in the coach where they both merge. The BIM only functions when the engine or generator is running or when the coach is connected to shore power.

To learn more, visit the Battery Isolation Manager home page in Newgle.



CHARGE BRIDGE SOLENOID

All current model New Aire, Mountain Aire, London Aire, Essex, and King Aire coaches use Silverleaf, a computerized coach management system.

One of its many functions is to control the battery charging through the Charge Bridge Solenoid. The TM102 module monitors the battery state and senses the house and chassis battery voltage. When the parameters are met, the TM102 module activates the solenoid, causing it to bridge or connect the chassis and house battery banks.

For more information on your coach’s TM102 module, refer to the SilverLeaf Functional Guide in Newgle.

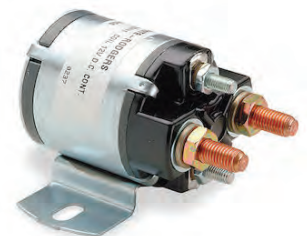

FUSE BLOCKS AND MINI-BREAKERS

When a 12 Volt wire is ran, most of the circuits are protected with fuses or mini-breakers. These can be located at various areas in the coach but are typically located near the main breaker panel. The following photos are examples only. However, they may also be found in areas such as:

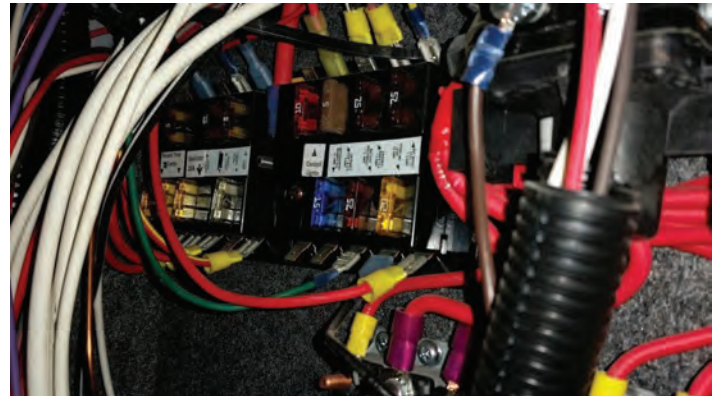
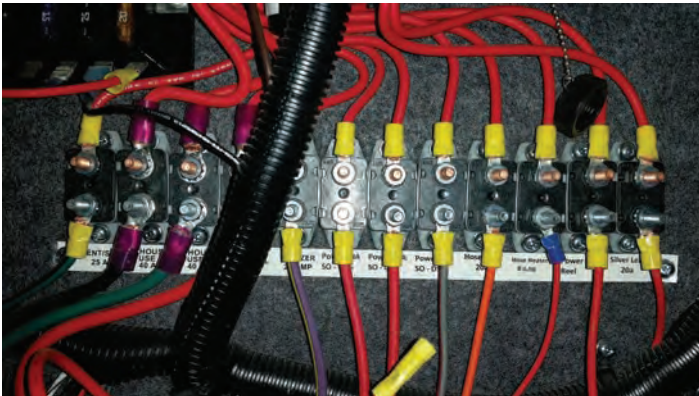

INTERIOR

- Rear bedroom
- Rear bathroom
- Closet

EXTERIOR

- Power cord compartment
- Left, front electrical compartment (located beneath the driver window)
- Front firewall (gas coaches)

There are also some circuits that are protected with an inline fuse. Some fuse blocks have fixed relays integrated on a board. The board below is located in the cord compartment.

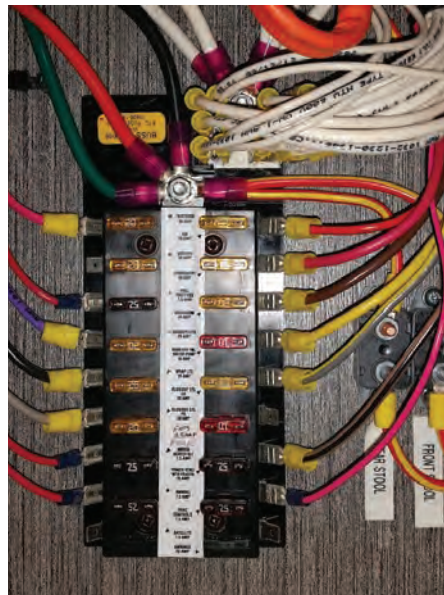

Basic 12 Volt Power Flow

Since a battery is only an electrical storage component, 120 Volt power must be present to charge the batteries from the converter or inverter/converter combination unit. It is necessary to have 12 Volt power supplied from the coach's house battery bank in order to operate the interior lights and other 12 Volt loads such as slideout control systems, water pumps, vent fans, monitoring systems, etc.

Most of this power flows through the battery disconnect to the fuse block or mini-breakers, which prevents overloading the circuit prior to progressing to the 12 Volt load. There are some 12 Volt circuits that do not go through the house battery disconnect; however, these loads still pass through a fuse or mini-breaker before progressing to the load.

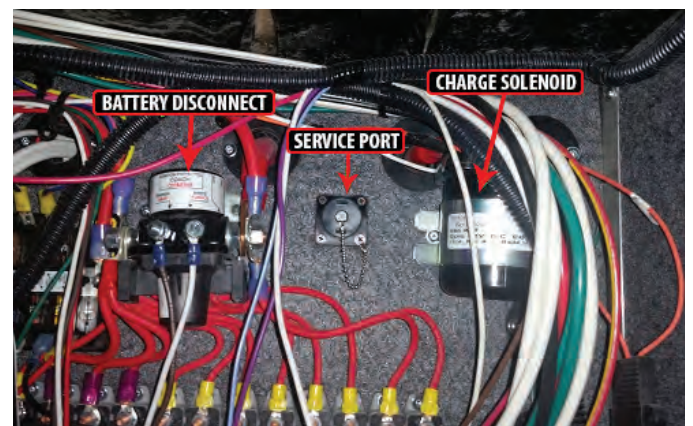

IMPORTANT

When a 12 Volt load or component is not working, both 12 Volt power (+) and 12 Volt ground (-) are needed for the load to complete the 12 Volt circuit.



120 Volt Electrical System

This article provides general information about the components and functions of the 120 Volt Electrical System (AC) in Newmar coaches.

Power Sources

There are three types of alternating current (AC) power sources available to the coach: shore power, generator power, and inverter power. Shore power is provided by the RV park or by home service outlets and should be used whenever possible. Generator power should mainly be used when shore power is not available, specifically while traveling, when 120 Volt power is necessary to run high amperage loads, or when dry camping requires 120 Volt for battery charging. Inverted power is mainly used for light 120 Volt loads when shore power is not available and generator power is not desired.

GENERATOR POWER

Generator power is produced within the generator and is output through the main wiring to the transfer switch. From the transfer switch, the power moves to the main breaker box where it is dispersed to individual circuits (outlets) and hard-wired components such as a water heater or boiler. From the inverted circuits, generator power will then travel through the inverter's internal transfer switch and back to the inverted subpanel to be dispersed through the individual breakers to the outlets or appliances.

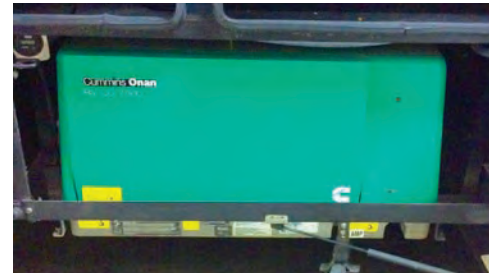

SHORE POWER

Most RV parks provide 30 Amp, 120 Volt at the site; however, many parks also provide 50 Amp, 240 Volt service to accommodate the electrical needs of newer and larger coaches. Shore power is supplied to the coach via a power cord. Two sizes of power cords are found in Newmar coaches: 50 Amp and 30 Amp. The 50 Amp cords are made up of four conductors #8 stranded wire and a molded plug. The 30 Amp cords are made up of three conductors #10 stranded wire and a molded plug.



Shore power enters through the 30 or 50 Amp power cord to the power cord reel (if equipped). From the power cord reel, it travels to the transfer switch and then to the main breaker box where it is dispersed to the individual circuits to supply power to hard-wired components such as air conditioners, water heaters, etc. and then to the inverter (if equipped).

The inverted circuits move from the inverter's internal transfer switch to the inverter subpanel (a smaller breaker box). From the subpanel, the power circulates to the individual breakers and to the electrical outlets and appliances.

SHORE POWER ADAPTERS

If an adapter is used, there are three common sizes of power cord adapters available to adjust to a smaller amperage outlet:

1. 30 amp to 20 amp
2. 50 amp to 20 amp
3. 50 amp to 30 amp

⚠ IMPORTANT

Newmar Corporation does not recommend use of adapter, cheater, or dog-bone style connectors that will modify the existing shore power cord to a different style of outlet. Use of this type of adapter will greatly reduce the amount of available current in the unit, as well as create the potential for electrical failure and/or fire.

It is important to understand the risks involved and the possible effects of using adapters in conjunction with your coach. Some of these risks and possible effects include:

- Melted or damaged adapters causing poor connection (or no connection at all)
- Melted or damaged 30 or 50 Amp plugs causing fluctuations in voltage that may damage electronics
- Insufficient amperage causing the tripping of a breaker at the post or a limited use of appliances



Low voltage can also be caused by use of adapters, long extension cords, or extension cords with an insufficient wire size.

⚠ IMPORTANT

Newmar Corporation cannot assume liability for failures occurring to the RV, its electrical system, or any of its components from the use of any electrical adapter.

INVERTER POWER

This type of power starts at the battery bank. The battery bank supplies 12 Volt power through cables to the inverter, which uses the 12 Volt direct current to produce 120 Volt alternating current. The inverter performs this action by using a transformer to increase the voltage and modify the higher voltage into a useable alternating current power. Power then goes to the inverted sub panel, which is dispersed through the individual breakers to the outlets or appliances.



The inverter may provide battery charging while 120 Volts is supplied via the generator or shore power. The inverter performs this action by using the transformer to decrease the voltage and rectify the alternating current into useable direct current voltage. This is regulated by internal sensing circuitry based upon the battery bank's state of charge and several other factors, depending on the coach's particular inverter brand and type.

AUTOMATIC TRANSFER SWITCH

Current coaches with a generator will also have a transfer switch installed in the cord compartment. An automatic transfer switch converts two inputs and connects them to a single common output.



The shore power cord is connected to one of the inputs, while the generator is connected to the transfer switch's second input.

Automatic transfer switches are logic-controlled to convert under a given set of conditions. The transfer switches used in RVs are typically generator priority switches which connect to shore power under normal use. As soon as the transfer switch detects the presence of 120 Volt power on the generator input lines, it will switch over to the generator's inputs and drop the connection to shore power.

Transfer switches are designed so that only one input can be connected at a time in order to prevent any back feeding of electrical power. In addition, RV transfer switches generally have a built-in delay allowing the generator to warm up and speed up before actually switching the load. This prevents stalling or stumbling while the engine is still cold and not producing full power.

MAIN SERVICE PANEL BREAKER BOX

The main service panel or 120 Volt breaker box is typically located inside a bathroom, bedroom, or front overhead cabinet depending on the coach model and floor plan. The breaker box contains the main 50 Amp (or 30 Amp if equipped) breaker and the individual breakers protecting each circuit from overload conditions. Any unit equipped with two air conditioners or more must have 50 Amp service. The task of the breaker is to "trip" if the current exceeds the amperage rating on the breaker to prevent damage to the wiring of the circuit.



The breakers are resettable by simply flipping the breaker to the 'off' position, and then back to the 'on' position once the overload condition is removed. All 120 Volt circuit breakers are located in the main service panel unless the coach is equipped with an inverter/charger. These units are also equipped with a subpanel.

⚠ IMPORTANT

Breakers positioned next to each other are on different poles in a 50 Amp panel. If only part of the electrical circuits are working, you may have a poor connection at shore power. In this instance, power is most likely only being provided to one pole or leg.

SUBPANEL

The subpanel is a smaller 120 Volt breaker box containing the breakers for the circuits which the inverter is wired to power. It is typically located near the main breaker box unless the coach is equipped with an Energy Management System (EMS). In this case, the subpanel is often located within the EMS panel.



The subpanel is installed to limit the AC power use to specific circuits when the electricity is supplied by the inverter. Some inverters may be used to power a specific circuit. In this case, a subpanel is not used.

AUTOMATIC GENERATOR START (AGS)

On units equipped with AGS, the generator will start and provide 120 Volt power if the incoming shore power voltage is not present and startup parameters are met.

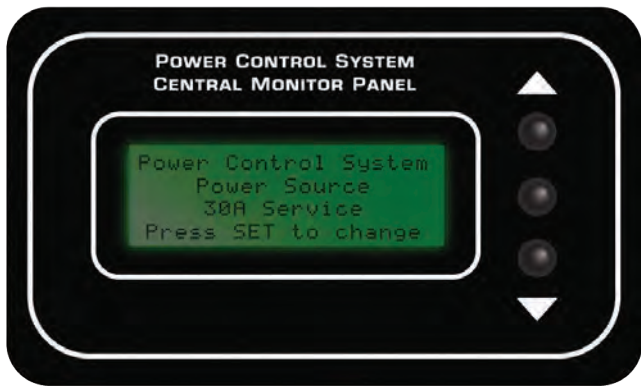

⚠ IMPORTANT

This function must be enabled in order for the AGS to function properly.

50 AMP ENERGY MANAGEMENT SYSTEM (EMS)

The 50 Amp Precision Circuits Energy Management System is currently offered as standard or optional equipment on all coaches not equipped with a SilverLeaf Coach Management System. Its function is to provide power management for certain 120 Volt loads and as a system of energy management to minimize the overloading and tripping of circuit breakers. The EMS contains a main distribution panel with a self-contained control module and a remote display panel, which is typically located in the dash overhead electrical control cabinet.



The EMS control module automatically senses the available power being supplied to the coach. The module determines whether it is connected to a 50 Amp (240 Volt) or the generator. On 120 Volt service, it is unable to determine if the source is providing 30, 20 or 15 Amp shore power. Depending on available power, it can control up to seven loads.

The EMS controls air conditioner loads using low-voltage switching and other 120 Volt, heavy-load appliances, such as block heaters, water heating elements, and air conditioners. The EMS will also control the 2012 Magnum inverter charge rate or switch to invert depending on the charging status. The charger will only reduce once it is in float status.

The current-sensing relay will display the amperage on each leg. The EMS will start shedding loads and look at the AC current when it sheds a load, determining when it has enough current available to turn on the load again.

When the EMS sheds a load, it only looks at one leg to see how much of a load was shed. For coaches equipped with the SilverLeaf system, refer to the SilverLeaf Functional Guide for more information on your EMS.

CONVERTERS

All Newmar coaches are equipped with a converter or an inverter/converter combination. Converters are used to transform alternating current power (120 Volt AC) to direct current power (12 Volt DC). Converters supply the coach with 12 Volt power to operate systems in the coach and provide battery charging.



Newmar currently uses three sizes of converters: 45, 60, and 80 Amp models. Previous units may have a 55 or 75 Amp converter or two 45 Amp converters with a total of 90 Amps available. When replacing a converter, it is necessary to use the same size converter to ensure sufficient wiring and breakers for the converter's input and output ratings.

Possible causes of converter failure:

- Overheating caused by cooling fan malfunction or inadequate ventilation causing damage to the converter
- Blown fuses

INVERTER/CONVERTER COMBINATIONS

Many Newmar coaches are equipped with inverter/charger combination units, sometimes referred to as an inverter/converter unit. These units range from 1200 to 3000 Watt and serve as a three stage charger and an inverter. Coaches equipped with this option will also be equipped with a 120 Volt subpanel.

The subpanel is used to limit the circuits powered by the inverter(s). This is necessary to avoid draining the batteries by supplying inverted power to all circuits. The subpanel is located next to the main service panel. On units equipped with an EMS, the subpanel is located in the same breaker box but is separated in the interior of main panel. The coach battery bank supplies the inverter 12 Volt power and has a high amp fuse link on the positive lead from the batteries and is located near the battery bank.

The inverter/charger can be controlled by a remote panel, from another system like SilverLeaf, or at the inverter itself. The remote panel is typically located in the front overhead compartment or above the entry door and is used to control the inverter and the battery charging functions. If a remote panel is connected to the inverter, then the remote panel takes priority.

INVERTERS

An inverter changes 12 Volt DC power to 120 Volt AC power. Coaches with an inverter only typically use it for powering the entertainment equipment like the TV, DVD, and Blu-ray players. The inverters used for this purpose are usually 600 watt to 1000 watt (1000 Watt inverters may also power a small refrigerator) and do not have battery charging capability.

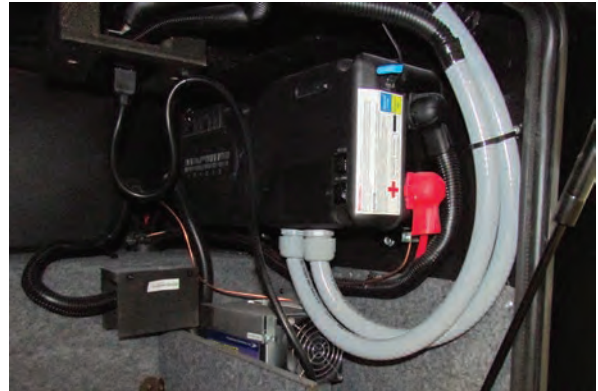

The inverters are usually located in a basement compartment of the coach. Some inverters have a remote panel for an on/off switch in the overhead driver area or above the entry door. When power is supplied by either the generator or shore power, the inverter merely allows the power to "pass through" and will then stop pulling power from the batteries to try and supply 120 Volt power. There is a protective breaker on the inverter to prevent circuit overload.

Possible causes for inverter failure:

- Overheating caused by inadequate ventilation causing damage to the inverter
- Overloading the circuit causing "tripped" breakers



THREE-STAGE CHARGING PROCESS

The charging cycle uses three states: bulk, absorption, and float. During the initial bulk stage, the inverter charges at near its full current ability. This causing the battery voltage to rise over time. After the battery voltage reaches the bulk voltage setting, the charger starts the absorption stage.

During this phase, the charge rate is gradually reduced while the battery voltage is held near the bulk voltage setting. This insures that the battery is fully charged. The float stage is initiated when the battery has been held at the bulk voltage setting for the absorption period. At this point the battery voltage is allowed to fall to the float voltage setting, where it is maintained until another charge cycle is initiated. This reduces gassing of the battery and keeps it fully charged. A new three stage charging cycle is initiated after an AC source is reapplied to the AC input terminals.

120 VOLT OUTLETS

Several 120 volt receptacles are located throughout the interior of the unit. These receptacles require three-pin plugs that provide proper grounding to protect you from electrical shock. The breaker for the outlets are usually located in the breaker box. If the breakers are on the inverted circuitry, they will be located in the subpanel near the main breaker box.



GROUND FAULT CIRCUIT INTERRUPT (GFCI) OUTLETS

The Ground Fault Circuit Interrupt (GFCI) outlets protect the user from ground faults between a hot wire and ground. The 120 Volt electrical outlets in the kitchen and bath area are GFCI protected receptacles. The electrical outlets located in the Slideouts are wired through the kitchen GFCI. The exterior electrical outlets are wired through the bathroom GFCI. On units equipped with the floor heat option, a separate GFCI is installed in the bathroom or near the main breaker box. Units with the holding tank heat pad option will have an additional GFCI located in the basement area; however, the exact location varies.



The GFCI outlets should be tested at least once a month. The 120 Volt electrical system must be energized in order to test the GFCI. The reset button needs to be pressed before starting the test. Then push the test button, which will cause the reset button to pop out, confirming the protected circuits have been disconnected. Push the reset button again until a click is heard to reactivate the protected circuit. If the GFCI is working properly, the reset button will remain in the "IN" position. If an item plugged into a Slideout or outside receptacle is not working, check for a tripped GFCI in the kitchen or bathroom. Likewise, if the floor heat or holding tank heat pads are not working, check the GFCI for that circuit.

⚠ IMPORTANT

Do not use an adapter, cheater, or extension cord that breaks the continuity of the ground circuit to the ground pin. Never remove the ground pin from a plug in order to connect it to a two-pronged ungrounded outlet.

⚠ WARNING

The GFCI will not reduce the shock hazard if the short is between a neutral and hot wire or two hot load wires.

Electrical Typical Amp Draw List

This article provides a basic overview of the typical amp draw of electrical components and appliances in a coach.

Knowing and understanding the electrical terminology, as well as the average amperage (current draw) of all the electrical appliances in your coach, can help you manage electrical use and prevent the inconvenience of tripping a breaker.

Amp Draw

Do you know how many Amps you are using at any single moment? It is surprising how quickly the current draw (Amps) of your appliances can add up for your coach's 30 or 50 Amp system. Knowing and understanding the electrical terminology, as well as the average amperage (current draw) of all the electrical appliances in your coach, can help you manage electrical use and prevent the inconvenience of tripping a breaker.

Below is a list of the typical appliances used and the approximate amps required to operate them.

- V= volt; volt is the measurement of electrical pressure
- A= amp; amp is the measurement of electrical current (volume) used by an electrical device.
- W=watt; watt is the measurement of how much electrical work is being done.

Appliance	Required Amps
Air Conditioner (depending on brand, BTU rating and options)	14.0 to 16.0 Amps
Inverter (depending on wattage rating, brand, and model)	9.0 to 18.0 Amps
Converter with continuous 12 volt power supply (depending on amp rating and brand)	11 to 17 Amps
Refrigerator (residential compressor-type)	8.5 to 12.0 Amps
RV Refrigerator (Absorption)	2.7 to 6.4 Amps
Microwave Oven	11.3 to 14.2 Amps
Washer and Dryer (2-piece)	16.0 Amps
Television (depending on size, brand, and type)	1.0 to 3.0 amps
Central Vacuum Cleaner	11.3 Amps
Electric Hot Water Heater (depending on brand and type)	11.7 to 12.5 Amps
Food Processor	6.0 Amps
Ice Maker	4.0 Amps
Electric Freezer (Compressor)	6.4 Amps
Hair Dryer (1500w)	12.5 Amps
Electric Coffee Pot	9.0 Amps
Iron	10.0 Amps
Radio	0.8 Amps
Toaster	8.0 Amps
Electric Frying Pan	10.0 Amps
Coffee Maker	10.0 Amps

Conversions

You can look at at your electrical appliances, find the label that contains amperage or wattage ratings and calculate exact usage by using the formulas below.

- $\text{Watts/Volts} = \text{Amps}$
- $\text{Amps} \times \text{Volts} = \text{Watts}$
- $\text{Watts/Amps} = \text{Volts}$

EXAMPLE

Most products requiring electricity provide how many amps or watts it typically utilizes. If your electric hot water heater is always in use (~12.5 amps), and you start your air conditioner (~15.0 Amps) and put on a pot of coffee (~9.0 amps) and make some toast (~8.0 amps) while watching TV (~ 2.0 amps), you have far exceeded the 30 amp service, resulting in a tripped breaker.

Many people don't take into consideration how much power may be used by the inverters charging circuits mostly because they are working automatically in the background. 50 amp service has two 50 amp power legs, providing a total service of 100 amps.

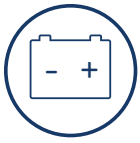

Batteries

Provides information about the house and chassis battery banks, battery inspection and care, as well as battery replacement.

Battery Basics

Introduction

As with anything technical, greater knowledge of the basics may help you increase performance, reliability, and longevity, as well as prevent future problems with your batteries. This article will provide information regarding your coach batteries; however, this is only one aspect of your coach's electrical system. To learn more about your batteries' role within the system, please refer to the 12 Volt Electrical article.

Commercial lead acid batteries have been used for over 150 years. The same chemical principal used to store energy now was also used many generations ago. Present day chassis battery power requirements are tremendous, considering today's vehicles and all of the electrical devices that must be supplied. All of these electronics require a reliable power source, and poor battery condition may lead to expensive electronic component failure. A battery is like a piggy bank - it stores energy, but cannot produce it. If you continue to withdraw without making any deposits, you will soon have nothing left.

Life Span Of A Battery

Not long ago, motor homes only used a single 12 Volt house battery. Today, however, it is standard to have at least two batteries, and up to 16 total in some Newmar coaches, powering inverters up to 3000 watts. As energy requirements increase, the average battery life decreases. The life span of a deep cycle battery will vary considerably with how it is used, how it is maintained and charged, temperature, and other factors. The life span is dependent upon usage but often ranges between six months to 48 months. Only 30 percent of all batteries actually reach the 48 month mark.

It is best practice to change the complete battery bank when a new battery becomes necessary, as the battery bank is only as good as the weakest cell. One simple way to extend battery life is to hook it up to a solar charger during the off months.

Common Battery Terms

Ampere (Amp) - A unit that defines the flow rate of electricity (current) in a circuit.

Amp Hour (AH) - Measurement of electrical storage capacity on a deep cycle battery. The standard amp rating is taken for 20 hours. Example: A 100 AH rated battery is determined like this: Draw from the battery for 20 hours provides a total of 100 amp hours, translating to about five amps an hour (5 amps x 20 hours = 100 AH). However, it is important to know that the total time of discharge and load applied is not a linear relationship. As your load increases, your realized capacity decreases. This means if you discharged that same 100 AH battery by a 100 amp load, it will not give you one hour of runtime. On the contrary, the perceived capacity of the battery will be about 64 AH.

Cold Cranking Amps (CCA) - Measures the number of amps a battery can deliver at 0° F for 30 seconds without dropping below 7.2 Volts (1.2 Volts per cell). A high CCA battery rating is especially important in engine-starting battery applications and in cold weather. This measurement is not particularly important in deep cycle batteries, though it is the most commonly known battery measurement.

Cranking Amps (CA) - Measures available current at 32° F and is also called marine cranking amps (MCA).

Depth of Discharge (DOD) - Measures the percent of rated capacity to which a cell or battery is discharged. It is the reciprocal of a battery's state of charge. Example: A battery that has a depth of discharge of 45 percent has a state of charge of 55 percent.

Reserve Capacity (RC) - Measures the number of minutes a fully charged battery can continuously deliver 25 amps at 80 ° F before the voltage drops below 10.5 Volts. This measurement represents the amount of time the battery can operate if a charging system failure occurs.

Electrolyte Specific Gravity (battery test) - Unit of measure which compares the weight of the electrolyte solution to the weight of water. This test is performed with a hydrometer or a refractometer that is made for testing batteries. This type of test is used to determine the battery's state of charge; however, it cannot be used on sealed batteries.

Battery Types

LIQUID LEAD ACID / FLOODED

The Lead Acid battery consists of a plastic container with cells molded into it. Each cell contains plates, lead, and lead oxide (various other elements are used to change density, hardness, porosity, etc.) with 35 percent sulfuric acid and a 65 percent water solution. This solution is called an electrolyte, which causes a chemical reaction that releases electrons.

When testing a battery with a hydrometer, the amount of sulfuric acid in the electrolyte is measured. If the reading is low, the chemistry that makes electrons is lacking. The sulfur is now resting on the battery plates and will remain there until the battery is recharged and the sulfur returns to the electrolyte.

ABSORBED GLASS MAT (AGM) / DRY CELL

The Absorbed Glass Mat battery is just like a flooded battery, except the electricity is maintained in the glass mats, as opposed to freely flooding the plates. Very thin fibers are woven into a mat to increase the surface area to hold sufficient electrolyte on the cells for their lifetime. The construction allows the electrolyte to remain suspended in close proximity with the plate's active material, enhancing both the discharge and recharge efficiency.

When Deep Cycle AGM batteries are not discharged more than 60 percent, the cycle life could be approximately a few hundred cycles. If you do not use or operate your equipment daily, AGM batteries will hold their charge better than most other types. In most cases AGM batteries will provide a greater life span and cycle life than a Wet Cell battery.

AGM batteries are also often referred to as Sealed Regulated Valve, Dry Cell, Non-Spillable, and Valve-Regulated Lead Acid batteries.

GEL CELL BATTERIES

The Gel Cell is similar to the AGM battery because the electrolyte is suspended; however, the AGM battery is still considered to be a wet cell. The electrolyte in a Gel Cell has a silica additive that causes it to set (gel) or stiffen. The recharge voltage on this type of cell is lower than the other types of lead acid batteries, due to the likelihood of an adverse reaction to over-voltage charging. Gel Cell batteries are best used in very deep cycle applications and may last longer in hot weather applications.

Battery Bank Wiring

PARALLEL BATTERY WIRING

Parallel battery wiring refers to two or more batteries with all positive (+) terminals hooked together and all negative (-) terminals hooked together. This results in a battery voltage similar to that of the individual batteries, typically 12 Volt, to boost battery capacity. Two identical batteries wired parallel will provide twice the electrical storage capacity of one battery, without increasing voltage.

SERIES BATTERY WIRING

Series wiring refers to two or more batteries hooked together, with opposite terminals connected. The positive (+) terminal of the first battery should be connected to the negative (-) terminal of the second battery. The resulting voltage is the sum of the individual batteries. For example, if two six Volt batteries are hooked together, the resulting voltage will be 12 Volts.

SERIES/PARALLEL WIRING

Series/ Parallel battery wiring is used on Newmar units when four or more 6 Volt batteries are used for the house battery bank. Since 12 Volts is the desired working voltage from the battery bank, the batteries are connected to provide 12 Volts with more capacity. Two 6 volt batteries wired together in a series create a 12 Volt battery bank. Two or more of the 12 Volt battery banks can be connected together in a parallel format to provide more capacity.

In situations where multiple batteries are connected in a series, parallel or series/parallel, replacement batteries should be the same size, type, and manufacturer (if possible). Age and usage level should be the same as the companion batteries.

Battery Cycle Vs. Battery Life

A battery cycle is one complete discharge and recharge cycle (100 percent to 20 percent, and then back to 100 percent). Battery life is directly related to how deep the battery is cycled each time. The most common cycles are 10, 20, and 50 percent. Be cautious of ratings that list the number of cycles, unless it also states how low the battery is being discharged.

For example, telephone type (float service) batteries have been advertised as having a 20-year life. However, the rating only stands true at five percent depth of discharge (DOD), and the life span is much less when used in an application where the batteries are cycled deeper on a regular basis. Those same batteries are rated at less than five years if cycled to 50 percent.

If a battery is discharged to 50 percent every day, it will last about twice as long as if it is cycled to 80 percent DOD. If cycled only 10 percent DOD, it will last about five times as long as one cycled to 50 percent. The most practical number to use is 50 percent DOD on a regular basis for the best use of effective storage and cost.

In addition, there is an upper limit. A battery that is continually cycled down five percent or less will usually not last as long as one cycled down 10 percent. At very shallow cycles, lead dioxide tends to build up in clumps on the positive plates rather than in an even layer.

Battery State/Voltage Chart

State of Charge	Specific Gravity	12 Volt	6 Volt
100%	1.265	12.7	6.3
75%	1.225	12.4	6.2
50%	1.190	12.2	6.1
25%	1.155	12.0	6.0
Discharged	1.120	11.9	6.0

⚠ IMPORTANT

This battery state voltage chart is used as an example. Your specific battery manufacturer's chart may vary.

Note: Both voltage and specific gravity tests should be performed with no load on the batteries and without any supplied charging. Turn off all draws and charging. Allow the batteries to stabilize, and then proceed with the test.

House and Chassis Battery Bank Overview

This article provides a brief overview of the two different battery banks in a Newmar coach: House and Chassis.

The House Battery Bank is necessary to operate everything a customer may require in order to live in the unit. These batteries can be either 6 Volt deep cycle (all diesel coaches) or 12 Volt deep cycle, depending on the model and brand of the coach. Newmar house batteries may be serviceable or sealed.

The Chassis Battery Bank supplies power to everything a customer requires to drive the unit. Currently, Newmar's chassis batteries are all Liquid Lead Acid. Spartan and Ford chassis have serviceable batteries and Freightliner chassis batteries are sealed. The type and brand of chassis battery may vary depending on coach year, make, and model. Chassis batteries may need to be disconnected and removed from the coach to maintain proper electrolyte levels or perform routine battery maintenance. House batteries may be either serviceable Liquid Lead Acid/Flooded or AGM/Sealed Cell.

The chassis batteries on your motorhome are installed and warranted by the chassis manufacturer. The coach (or house) batteries on your motorhome are installed by Newmar Corporation, but warranted by the battery manufacturer. These batteries are used to operate the 12 volt items that are not a direct part of the chassis. Depending on the coach, the batteries may be located in the front of the coach under the front cap or on a pull out tray in an outside compartment.



House Battery Bank Example



Chassis Battery Bank Example

⚠ CAUTION

Do not use the motorhome with the coach batteries disconnected.

The chassis batteries are recharged by the vehicle's electrical system whenever the engine is running, with added BIRD, BIM, or Charge bridge solenoids the vehicle's charging system will also charge house batteries if parameters are met. A decline in the coach battery voltage may be noticed while the chassis batteries are being charged.

The converter will automatically charge the coach batteries when the unit is connected to a 120 volt outside power source. The chassis batteries are isolated from the coach batteries, however with certain parameters met the BIRD, BIM, or Charge bridge will activate and allow charge to the chassis battery also. This prevents the chassis batteries from being drained by the interior 12 volt equipment, allowing ample voltage for engine ignition.

Battery Inspection, Safety, Care, and Maintenance

This article provides information regarding the inspection, care, and maintenance for coach batteries. Battery maintenance is an important issue often overlooked by many RV owners and technicians. As batteries age, their maintenance requirements change. This means longer charging time and/or higher finish rate (higher amperage at the end of the charge). Usually older, serviceable (unsealed) flooded batteries need to be watered more often, as their capacity decreases over time.

⚠ IMPORTANT

These brief operation instructions are for quick reference only and should not take the place of the complete manual(s) provided by this product's manufacturer. Refer to the corresponding links and files in Newgle for more details about your product.

Safety Guidelines

⚠ WARNING

Remove rings, metal watch bands, and other metal jewelry before working around batteries. Use caution when using metal tools. If a tool contacts a battery terminal or metal connected to it, a short circuit could occur, which could cause personal injury, explosion, or fire.

⚠ WARNING

Prior to handling or working with a lead-acid battery, consult your battery owners' manual for instructions and safety precautions.

⚠ CAUTION

Disconnect the 120 volt electrical power cord and the negative terminal from the coach batteries, and make sure all power sources are disable (ignition, generator, shore power, inverter) before working on the electrical system.

Lead-acid batteries contain hydrogen-oxygen gases that may be explosive and sulfuric acid that may cause severe burns. To avoid injury, observe these precautions when handling or working with a lead-acid battery:

- Wear ANSI (American National Standards Institute) approved safety glasses or goggles, as well as a face shield.
- Wear proper clothing to protect your face, hands, and body.
- Work in a well-ventilated area.
- Never lean over a battery while boosting, testing, or charging.
- Keep all ignition sources away from the battery. Cigarettes, flames, or sparks could cause a battery to explode.
- Always shield eyes and face from the battery.
- Do not charge or use booster cables or adjust post connections without proper instructions and training.
- Keep vent caps tight and level.
- In the event of an accident, flush eyes or skin with water, and call a physician immediately.
- Keep out of reach of children.

Storing The Batteries

Remember that when batteries are not used for an extended period of time, they may lose their charge. Periodic charging of the batteries during storage of the unit will increase the life of the battery. Check the external condition of the battery periodically. Look for cracks in the cover.

The batteries should be removed and stored in a warm place when not using your motorhome for an extended period of time. This will prevent unnecessary drain and corrosion of the batteries. The coach batteries are 6 volt RV/Marine deep cycle batteries. Mark the cables, positive and negative, for easy identification. Batteries are not to be stored on concrete floors.

Common Causes Of Premature Battery Failure

- Deep discharges (leaving your lights on)
- Misapplication
- Replacement using an undersized battery not meeting Newmar's OEM specifications
- Loss of electrolyte due to overheating or overcharging
- Undercharging or loose alternator belt
- Excessive vibration (due to loose clamp or hold down on battery)
- Corrosion
- Freezing (A fully-charged vehicle battery will not freeze until the temperature is -75° F. Frozen batteries are not warrantable.)
- Failure to charge a battery during a period of six months or more (Inactivity can be extremely harmful to all lead acid batteries.)

Cleaning The Batteries

Check the vent plugs and replace them if they are cracked or broken. Keep the battery clean. Accumulations of acid film and dirt may permit current flow between the terminals, which could drain the battery.

To clean, wash the batteries with a diluted solution of baking soda and water to neutralize any acid present. This should be a mixture of a couple of tablespoons of baking soda per pint of water. Rinse thoroughly with clean water. Foaming around the terminals or on top of the battery is a sign that acid is being neutralized. Avoid getting the baking soda solution in the battery. Secure all vent caps.

Both house and chassis battery cable connections need to be cleaned and tightened, as battery problems are often caused by dirty and loose connections. Dry the battery cables and terminals to prevent corrosion. Do not use grease on the bare metal inside the cable terminals. Grease can act as an insulator, and electricity will not flow through it. A plastic ignition spray will protect the terminals after they have been cleaned.

⚠ WARNING

Do not allow the battery fluid to contact your skin, eyes, fabric, or painted surfaces. The fluid could cause serious personal injury or property damage. Wear eye protection when working with any battery.

Checking The Fluid Level and Adding Fluid

A serviceable battery needs to have the fluid level checked, as they consume water and must be filled periodically. Please be sure to check the battery water level on a regular basis.

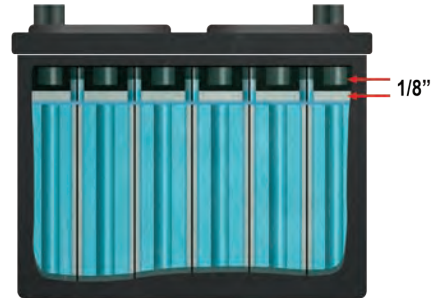

1. A serviceable battery needs to have the fluid level checked. AGM batteries do not require additional fluid. If the battery has removable vent caps, they can be twisted or pried off with a flat-head screwdriver. Once removed, the individual vent wells can be seen. Look down into each individual cell to make sure that the water is covering the lead plates and is at the proper level.
2. Add water to any cells that are low on water. Ideally, the water level should be 1/8" below the bottom of the tubes (there are six tubes in a 12 Volt battery) that go down into the battery. To avoid damage to the battery, make sure the fluid level never drops below the tops of the lead plates in each of the cells. Always use distilled water to fill the battery to prevent battery contamination.
3. Do not overfill battery cells. Adding too much water may result in acid overflow and damage around the battery. In addition, warmer weather may cause natural fluid expansion, forcing excess electrolytes from the battery.

Preventing Corrosion

Newmar sprays the battery connections once they are tightened with a battery protector and sealer to help prevent corrosion. When performing battery maintenance, you should reseal the battery terminal connections. The following measures may also prevent future corrosion:

Use a small bead of silicone sealer at the base of the post where it meets the battery case. Place a felt battery washer over the post and into the bead of silicone. Coat the washer with high temperature grease or petroleum jelly (Vaseline), then place the cable on the post and tighten. Coat the exposed cable end with the grease. The gas condensation on metal parts of the battery cause most corrosion issues.

Battery Replacement

This article provides information about how and when to replace coach batteries.

Replacement batteries should be the same brand and capacity as the originals. Any time one battery is replaced, it is important to test the rest of the batteries in the system to make sure they are still functioning properly and efficiently. If one defective battery is replaced, while leaving another weak or defective battery, lowered performance, or ultimately damaging the new or good batteries, may result.

IMPORTANT

Charging batteries release gasses as the fluids inside boil, so it is critical to check the battery fluid levels regularly, particularly after extended periods of heavy use. Be sure to top off any battery that is showing signs of depleted fluid levels.

A battery wiring label is located inside of the battery compartment and shows how the batteries are wired together. Replacement batteries must be wired according to the diagram shown.

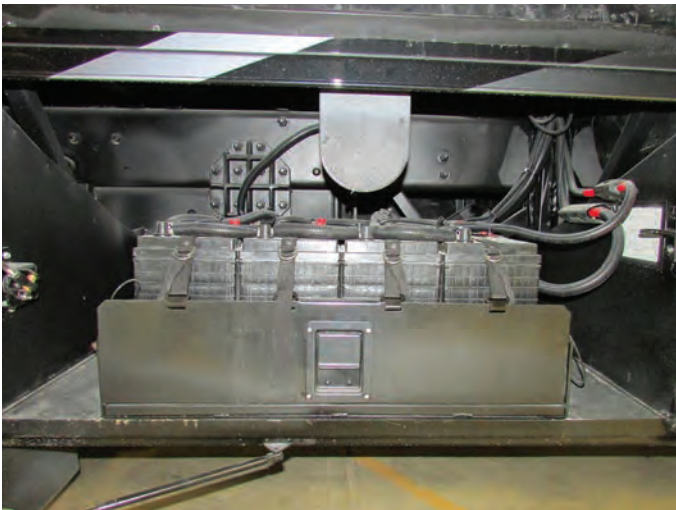

On diesel coaches, the house batteries are normally located in one of the lower compartments. The chassis batteries are normally on the passenger side in the rear compartment on diesel pushers and under the driver's side cab on the front engine on Super C coaches.

On coaches built on a Ford chassis, batteries are normally located in the front of the coach and can be accessed by opening the hood.

Battery Boost Switch Overview

This article provides the Newmar-recommended step-by-step instructions for operating the battery boost switch.

The **Battery Boost** switch is located on the dash and, when pressed, momentarily connects the house batteries to the chassis batteries via the solenoid. This allows the chassis batteries to obtain power from the house batteries to assist in starting the engine.



If the chassis batteries cannot turn the engine over, hold down the **Battery Boost** switch and attempt ignition. By using the **Battery Boost** switch while trying to start the chassis engine, the house battery bank supplies a battery voltage boost to the chassis batteries if the house battery bank voltage is higher than the chassis battery bank.

If the battery boost switch is required to start the engine on a regular basis, ask your dealer to check the chassis batteries and charging system.

Battery Disconnect Switch Overview

This article provides information about the **Battery Disconnect** switch. The switch is used to disconnect the battery when the unit is stored for any period of time. Pressing downward disconnects the coach batteries, not the chassis batteries. This is done to prevent the coach batteries from being drained during storage. It disconnects most of the 12 volt circuitry from the batteries, with the exception of the LP detector and various memory features. When taking the unit out of storage, press upward to reconnect the batteries. This will make the 12 volt system ready for use.



Depending on the chassis of the coach, diesel pusher motorhomes may be equipped with a second disconnect switch strictly for the chassis batteries. If equipped, this "Master Kill Switch" may be located in the rear engine compartment or chassis battery compartment. This switch disconnects all power to the chassis so that the engine cannot be started. It is used to prevent accidental ignition when the engine is being serviced.



Energy Management Systems

This article provides an overview of the energy management systems used by Newmar. The energy management and auto generator start systems work behind the scenes to monitor the power supply and demand within the coach. The system is designed to minimize the occurrence of tripped breakers for shore power and the generator while heavy loads are being used. The system turns off other loads temporarily while heavier loads are in use and restores power when heavy loads are turned back off.

When 50 amp service is available, no action is required; however, 30 amp service (or less) requires setting the value of incoming power to be selected.

⚠ NOTICE

Whenever possible, connect coaches equipped with 50 amp shore power cord to 50 amp service, and connect coaches with 30 amp shore power cords to 30 amp service accordingly. It is the best practice to avoid using adapters and cheater cord devices.

Auto generator features may vary by coach model and options. Most AGS systems start the generator if shore power is unavailable and the HVAC system signals for air conditioner operation. Many systems will also start automatically if battery levels reach the preset values.

For more information about the energy management system, refer to the SilverLeaf Coach Management or Precision Circuits Power Control System documentation found in Newgle, depending on which system is installed in the coach.

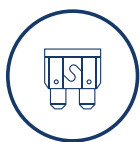

Fuse Panels

This article provides information and the location of the house and chassis fuse panels.

Fuse Panels on Coaches Built on Ford Chassis

Inside The Coach

On a class A coach, the house fuse panel, which controls most of the components and appliances inside the coach, is located in the bathroom. This panel contains fuses and breakers that are connected to all main appliances in the coach, from the refrigerator and television to the lights in the bedroom and slideouts.

There are also some external components that are fused in the house fuse panel. For example, the fuses for the water pump, water heater, awning, and basement storage lights may be located in this panel.



House Fuse Panel Example

⚠ NOTICE

On Canyon Star 3911 models (handicap accessible units), this panel is located on the back wall of the bedroom, next to the 120 volt breaker panel.

The Ford chassis fuse panel is located on the sidewall, left of the driver's feet. This fuse panel supplies power to exterior lights, the tow plug, and the wipers. For exact details, see the Ford manual.

To access the Ford fuse panel on the passenger side under the dash, rotate the clips on the sides of the cover to release and remove the cover. To remove the black fuse retainer, pinch the two tabs together, and pull out on the retainer to gain access to the fuses. To replace the cover when finished, install the retainer by aligning and pressing in until the fuse retainer snaps in place. Install the cover, and rotate the retainer clips to hold the cover in place.

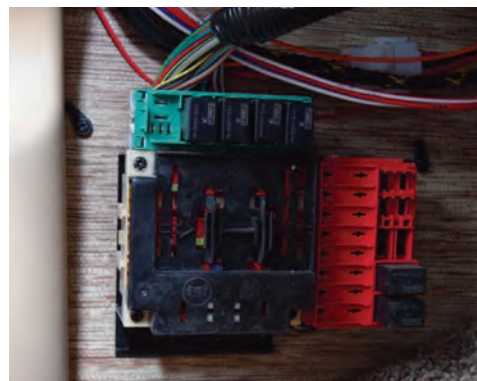

Ford Chassis Fuse Panel Example

Outside The Coach

House battery and disconnect fuses are located under the hood of the coach. These fuses control the battery boost, battery disconnect, and entrance steps. In this same location, there are also 12 volt circuit breakers that provide power to the ignition, house fuse panel, inverter, and the power seats (if equipped).

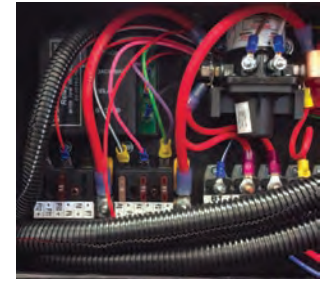

Generators

This article provides information for maintenance, operation, and safety for gas and diesel generators.

Generator and GenStart/Stop Switch Overview for Diesel Coaches

This article provides basic operation instructions for a generator and GenStart/GenStop switch on a diesel coach.

The generator is wired into the Automatic Transfer Switch and will power all of the 120 volt circuits in your coach. Your generator may be located in a side compartment or in the front of the coach in between the frame rails of the chassis. Some generators are mounted on slides for easy access and may need to be unlocked before free movement is allowed. The main breakers for the output legs are located on the generator start panel.



Operating The Generator

The generator can be started from the rocker switch on the dash, from other remote start switches (if equipped), or from the start switch on the generator itself.

The generator in your coach runs on the same fuel as your main engine. The fuel is drawn through a separate supply tube that is positioned in the tank in a manner that will not allow the generator to draw fuel and run if the tank level dips below the ¼ level.



IMPORTANT

These brief operation instructions are for quick reference only and should not take the place of the complete manual(s) provided by this product's manufacturer. Refer to the corresponding links and files in Newgle for more details about your product.

PRIOR TO STARTING THE GENERATOR:

- Before starting the generator, turn off all air conditioners and large electrical loads.
- Before starting the generator in cold weather, turn off all appliances to maintain peak performance.
- Prime the generator by holding down the STOP button.

TO START THE GENERATOR:

- Press and hold the START button on the control panel or at the generator. The indicator light will flash as the generator is cranking and remain illuminated once the generator is running. Release switch after generator has started. - If generator is not starting, Do not over-crank.
- Before turning on appliances, let the generator warm up for a few minutes.

TO STOP THE GENERATOR:

- Turn off all air conditioners and large electrical load.
- Allow the generator to run for three to five minutes to allow the generator to cool down.
- Press the rocker switch to the STOP position, and release it. The generator will stop running, and the indicator light will turn off.

⚠ IMPORTANT

Excessive cranking can damage the starter motor. Do not crank the generator more than 30 seconds at a time, and allow at least two minutes before trying again if the first attempt fails.

⚠ CAUTION

Failure to turn off the 120 volt appliances when starting or stopping the generator may damage the transfer switch and/or electrical appliances.

⚠ DANGER	⚠ DANGER
Vehicles and equipment powered by internal combustion engines and placed in recreational vehicles can cause carbon monoxide poisoning or asphyxiation, which could result in death or serious injury. The flammable liquids used to power these items can cause a fire or explosion, which can result in death or serious injury.	Les véhicules et l'équipement propulsés par un moteur à combustion interne placé dans un véhicule de camping peuvent causer un empoisonnement au monoxyde de carbone ou l'asphyxie, ce qui pourrait entraîner des blessures graves ou la mort.
To reduce risk: a) Do not ride in the vehicle storage area when vehicles are present. b) Do not sleep in the vehicle storage area when vehicles are present. c) Close doors and windows in walls of separation (if installed) when any vehicle is present. d) Run fuel out of engines of stored vehicles after shutting off fuel at the tank. e) Do not store, transport, or dispense fuel inside this vehicle. f) Open the windows, openings, or air ventilation systems provided for venting the transportation area when vehicles are present. g) Do not operate propane appliances, pilot lights, or electrical equipment when motorized vehicles are present.	Les liquides inflammables utilisés pour propulser ces machines peuvent causer un incendie ou une explosion, ce qui peut entraîner des blessures graves ou la mort. Pour réduire le risque: a) Ne pas circuler dans l'aire de rangement du véhicule si des véhicules s'y trouvent. b) Ne pas dormir dans l'aire de rangement du véhicule si des véhicules s'y trouvent. c) Fermer les portes et fenêtres qui se trouvent dans les cloisons (le cas échéant) si au moins un véhicule est entreposé. d) Égaliser le carburant contenu dans les moteurs des véhicules entreposés après avoir coupé l'alimentation en carburant au réservoir. e) Ne pas entreposer, transporter ou distribuer de carburant à l'intérieur de ce véhicule. f) Ouvrir les fenêtres, ouvertures ou systèmes de ventilation d'air fournis pour ventiler la zone de transport lorsque des véhicules s'y trouvent. g) Ne pas faire fonctionner d'appareils au propane, de veilleuses ou d'équipement électrique en présence de véhicules motorisés.

Generator Maintenance

Before starting your generator for the first time each day, and subsequently after each eight-hour run cycle, perform the following checks to make sure it is ready to be used.

1. Make sure the carbon monoxide detectors in your unit are working.
2. Check for signs of fuel or exhaust leaks.
3. Make sure there is adequate clearance around the generator for proper ventilation. Also check for sloping ground or any other obstructions that may have occurred. Tall grass or other items that come in contact with the generator may interfere with ventilation or cause a fire.
4. Check the oil and coolant levels, and inspect for leaks.
5. Check the battery connections to make sure they are tight and clear of corrosion.
6. Inspect the generator compartment for road debris or damage that might affect the performance or safety.
7. Turn off major appliances (such as air conditioners, televisions, and other electronics that may excessively load the generator or may be sensitive to initial voltage surges).

The hour meter installed on the generator calculates the number of running hours of the generator motor. This is used for maintenance schedules. Regular oil changes and other maintenance performed at the prescribed intervals will greatly extend the life of your generator.

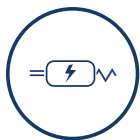

Inverters and Converters

Provides basic information about the role and operation of inverters, converters, and inverter/converter combination units.

Inverters

The inverter modifies direct current to alternating current to provide power to specified appliances and entertainment systems. The inverter performs this action by using a transformer to increase the voltage and modify the higher voltage into a useable alternating current power. For this function to occur, the inverter must be powered, set up, and turned on. A variety of inverters are used by Newmar; however, most have a control panel located in the overhead cabinet with other switches and controls.

Inverter/Converter Combination Units

The inverter/converter combination provides battery charging and allows the 120 volt power from shore power or the generator to pass through the inverter. The inverter performs this charging action by using the transformer to decrease the voltage and rectify the alternating current into useable direct current voltage. This is regulated by internal-sensing circuitry based upon the battery bank's state of charge and several other factors, depending on the coach's particular inverter brand and type.

This type of unit also performs the inverter function. For this function to occur, the inverter must be powered, setup and turned on. A variety of combination units are used by Newmar; however, most have a control panel located in the overhead cabinet with other switches and controls.

Converters

A converter transforms alternating current or shore line power 120 volts; to low-voltage direct current to provide power to the coach's 12 volt house and chassis batteries. This function occurs automatically when 120 volts are supplied to the converter. Converters are usually located in the cord compartment of coaches that do not have a inverter/converter combination unit.

Progressive Dynamics Intelli-Power Converter Operation (PD9100/PD9200 Series)

This article provides basic operation instructions for a Progressive Dynamics Intelli-Power Converter (PD9100/PD9200 Series).

General Operation

The INTELI-POWER series converter will supply “clean” power from input voltages that range from 90-130 VAC.

The INTELI-POWER series of converters are primarily designed for use with a battery, however, the output of the INTELI-POWER converters are a regulated, filtered DC voltage that can power sensitive electronics without the need for a battery or other filtering.

At normal input voltages the full load rated capacity is available. At input voltages less than 105 VAC the converter may not supply full rated output capacity.

9100

The full rated load is available for load, battery charging or both. When functioning as a regulated battery charger the converter has a nominal voltage output of 13.6 VDC for 12 volt models. The system is designed to sense voltage on the battery and will taper the charging current as the battery becomes charged.

When the vehicle is to be stored for extended periods of time it is recommended that the batteries be disconnected, unless a TCMS Charge Wizard is attached to the TCMS interface. Reconnect battery once a month to maintain a full charge.

9200

The full rated load is available for load, battery charging or both. When functioning as a regulated battery charger the converter has a nominal voltage output of 13.6 VDC for 12 volt models. The system is designed to sense voltage on the battery and automatically selects one of three operating modes (normal, boost and storage) to provide the correct charge level to the batteries.

BOOST MODE

If the converter senses that the battery voltage has dropped below a preset level the output voltage is increased to approximately 14.4 VDC to rapidly recharge the battery.

NORMAL MODE

Output voltage set at approximately 13.6 VDC.

STORAGE MODE

When the converter senses that there has been no significant battery usage for 30 hours the output voltage is reduced to 13.2 VDC for minimal water usage. When in storage mode the microprocessor automatically increases the output voltage to 14.4 VDC for approximately 15 minutes every 21 hours to help prevent sulfation of the battery plates.

CAUTION

It is important that the fluid level of any connected batteries be checked on a regular basis. All batteries will “gas” and lose some fluids when continuously connected to any charging source.

TCMS Charge Wizard

Your INTELI-POWER converter is equipped with a TCMS interface. The TCMS Charge Wizard pendant plugs into the TCMS interface to provide computer control and monitoring of your batteries charge state. The Charge Wizard automatically determines which operating mode is best suited to recharge or maintain optimum battery condition. The Charge Wizard Pendant (if equipped) allows for manual override and has an indicator light to indicate the mode of operation.

BOOST MODE

Indicated by green LED remaining on.

NORMAL MODE

When the battery is between 50% and 90% charged, the green LED will flash once per second. When the battery has reached 90% of full charge the green LED will flash 2 - 3 times per second.

STORAGE MODE

Indicated by green LED flashing every 6 - 8 seconds.

MANUAL MODE

The manual button has been provided to allow the operator to temporarily override the converter (not recommended) or to verify the converter is operating properly. For manual operation, press and hold the button. The indicator light will soon remain "ON" indicating Boost Mode. Continue to hold the button and the light will blink rapidly indicating the converter is in the Normal Mode. Continue to hold the button until the light blinks slowly indicating the converter is now in the Storage Mode. After the manual button is released the converter will stay in the selected mode. When the battery charge status changes, the converter will return to the automatic mode of operation to prevent damage to the battery.

Source: Inteli-Power PD9100/9200 Series Power Converter Owner's Manual

Xantrex Freedom X Sine Wave Inverter Operation (1200 and 2000 Watt)

This article provides basic operation instructions for a Xantrex Freedom X Sine Wave Inverter (1200 and 2000 Watt). Coaches requiring two or more 1200 watt inverters (Newmar option) will automatically be upgraded to a single Xantrex 2000 watt inverter with charger (Model 2080).

LCD Screen or Remote Panel

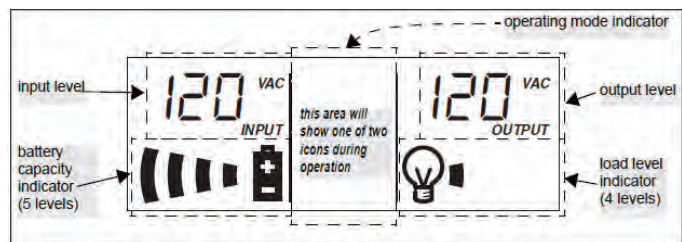

The LCD Screen changes depending on the operating mode of the inverter.

LCD Screen Icons and LED Light Indicators

Icon	Definition
	Appears in all modes. Indicates ~ 75-100% battery capacity.
	Appears in all modes. Indicates ~ 50-75% battery capacity.
	Appears in all modes. Indicates ~ 25-50% battery capacity.
	Appears in all modes. Indicates ~ 1-25% battery capacity.
	Appears in all modes. Indicates 0% battery capacity.
	Appears in AC mode only and sometimes in Fault mode. Indicates ~ 75-100% load capacity.
	Appears in AC mode only and sometimes in Fault mode. Indicates ~ 50-75% load capacity.
	Appears in AC mode only and sometimes in Fault mode. Indicates ~ 25-50% load capacity.
	Appears in AC mode only and sometimes in Fault mode. Indicates ~ 0-25% load capacity.
	Indicates AC mode in which shore power is available and passing through to the loads.
	Indicates Battery mode (Inverter mode) in which the inverter is running and supplying power to the loads from the battery.

Indicator	Definition
	Indicates AC mode in which shore power is available and passing through to the loads.
	Indicates Battery mode (Inverter mode) in which the inverter is running and supplying power to the loads from the battery.
	Indicates Fault mode and is accompanied by an error code displayed on the LCD screen.
	Indicates a Warning condition and is accompanied by an error code and a sounding alarm.

AC Mode

AC Mode is when AC shore power is available as input and the power is passing through as output. The display may look similar to this:

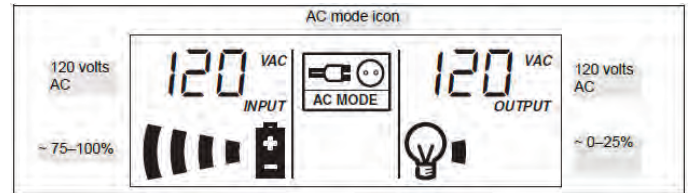

OPERATING IN AC MODE

The Freedom X operates in AC mode when an AC source (a generator or utility power) is present at the AC input terminals. When the AC source is within operating range (meaning the voltage is, the Freedom X unit bypasses inverter mode and powers the appliances connected to the unit. The green status LED lights up to indicate the Freedom X is using utility (or generator) power.

When shore power is present, AC power automatically passes through the Freedom X. Pressing the inverter Power button on the display panel does not interrupt the supply of shore power. AC Mode supersedes inverter operation.

When the Freedom X's inverter Power button is turned ON and the AC source is outside the operating range or is disconnected, the transfer switch automatically switches to Battery Mode.

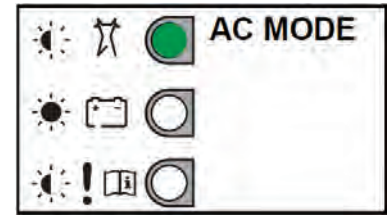

Battery Mode

In Battery Mode (also called Inverter Mode), the AC output power comes from the battery. The LCD Screen switches to displaying battery mode information such as:

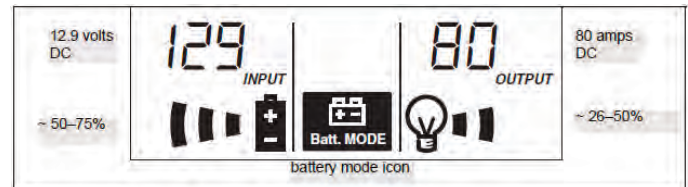

OPERATING IN BATTERY MODE

The Freedom X is in Battery Mode (also called Inverter Mode) when all the following conditions exist:

- inverter power button is ON (down position) or ignition auto-on is activated
- shore power is not presently available
- battery has sufficient power

Inverter operation means that DC battery power is presently being converted to utility grade AC power, powering equipment and appliances connected to the AC output terminal of the unit.

The green status LED lights up to indicate the Freedom X is using the battery to power the equipment and appliances.

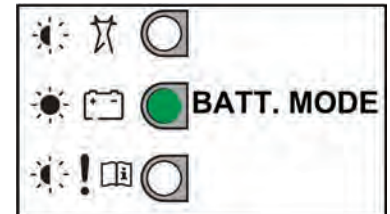

VIEWING INFORMATION DURING BATTERY MODE

The LCD screen displays Inverter information as well as feature settings in coordination with the LED lights alongside the screen.

- Press the Scroll UP button to toggle between the following basic information:

INPUT VOLTAGE/OUTPUT VOLTAGE

- Default screen
- Shore power voltage = 80V
- Output voltage = 120V

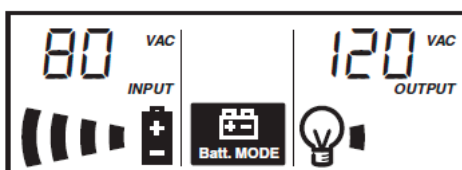

BATTERY VOLTAGE/BATTERY DISCHARGE CURRENT

- Battery voltage = 13.1V
- Battery discharge current = 80A

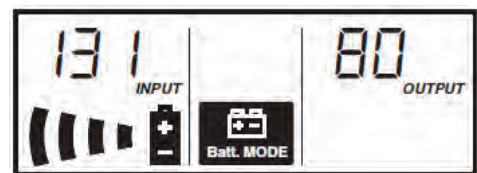

WARNING/FAULT

- If a fault or warning is detected, this screen becomes the default screen.
- Error code = E02 “DC Input Over Voltage shutdown”

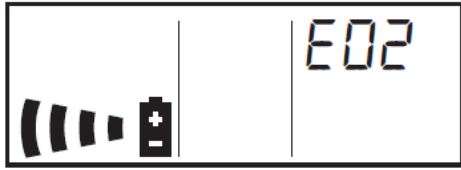

LOAD PERCENT

- Load = 20%

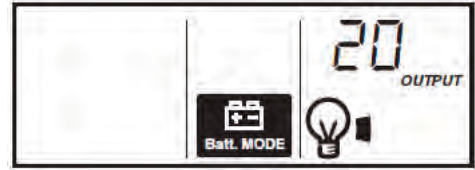

Idle Mode

When there is no AC output such as when an error or fault condition is detected, the Idle Mode is displayed on the LCD Screen. An example is shown below:

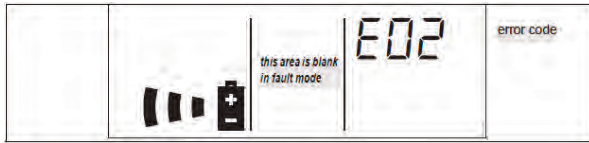

For definitions on battery capacity, load level, and error code indicators, refer to the “LCD Screen Icons” section.

Turning Inverter Operation On and Off

There are two ways to operate the Freedom X’s inverter.

- Press the inverter Power button to a down position (it is Off in the up position).
- When the inverter’s Ignition Control feature is set to Auto-on, and the Ignition Control switch is enabled and, a +12VDC signal is present.

⚠ WARNING

ELECTRICAL SHOCK HAZARD: Turning the inverter Power button off does not disconnect DC battery power from the Freedom X. You must disconnect both AC and DC power before working on any circuits connected to the unit. Failure to follow these instructions can result in death or serious injury.

To prevent unnecessary battery discharge, press the inverter Power button to turn it off when you are not using the Freedom X.

Checking Battery Status

During inverter operation (in battery mode), you can check the battery status by observing the battery capacity indicator on the LCD screen. The battery voltage appears in the left side of LCD screen. The normal operating battery voltage range is between 11 and 15 volts.

Checking Output Power

When the inverter is in operation (in battery mode), you can check how much power (displayed in Amps) the Freedom X is supplying to the connected loads by observing the load capacity indicator on the LCD screen. The battery discharge amperage appears in the right side of the LCD screen.

Operating Several Loads At Once

If you are going to operate several loads from the Freedom X, turn them on one at a time after you have turned the inverter on. Turning loads on separately helps to ensure that the inverter does not have to deliver the starting current for all the loads at once, and will help prevent an overload shutdown.

Turning The Audible Alarm On or Off

The Freedom X's audible alarm can be silenced. Any warnings such as fault conditions or imminent shutdown are both displayed on the LCD screen and sounded on the alarm speakers. It is not possible to turn OFF the screen and prevent it from displaying error codes but it is possible to turn OFF the audible alarm.

To reset the alarm:

- Press the inverter Power button to turn it Off (from a down position to up) and press again to turn it On to reset an active alarm and clear the fault.

Resetting AC Output

The 15 amp resettable breaker is located on the inverter near the outlet.

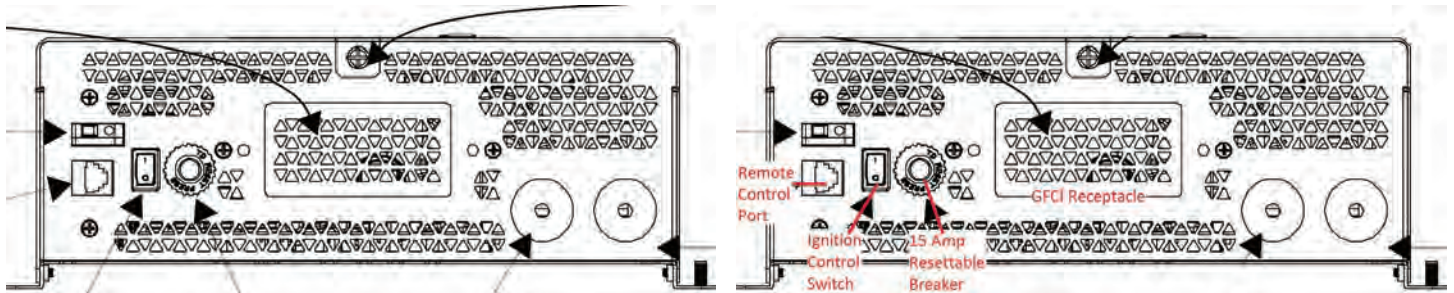

Lighting

A Newmar coach's electrical and lighting system is designed for maximum reliability, functionality, and style.

Interior and Exterior Lights

Provides basic information about operation, maintenance, and replacement of interior and exterior lights.

Interior Lights

Your coach may feature traditional on/off switches or multi-switch touch panel light and accessory switch panels. Located throughout the unit, these switching devices are used to turn lights on and off, as well as to operate power shades and window treatments. Many coach models boast LED accent lights and new cloth-shaded LED wall sconces custom-designed for Newmar.

Flip the switch or touch the switch panel to operate the light or accessory you desire. Some lights may also have dimming features, allowing you to adjust the interior lighting for mood or comfort. For more details about the interior lights, refer to the documentation in Newgle.

Many of these bulbs are made as both filament and LED. Most LED bulbs are polarity-sensitive unlike filament bulbs. When attempting to replace filament-type bulbs with LED-type bulbs, it is possible for the light fixture to be wired in reverse polarity for the LED replacement bulbs. Switching to a different type of bulb may require a wiring change. Newmar recommends any wiring modifications be performed by an authorized service technician.

IMPORTANT

When replacing halogen bulbs, do not touch the bulb, as the oil from your hands will reduce the bulb's life.

Turn off the lights to avoid possible short circuits, blown fuses, and burns while removing and replacing bulbs or lights. Depending on the year and model of your coach, it may be equipped with LED light fixtures with the lights embedded into the light housing.

Many of the LED light fixtures have integrated LED assemblies that are non-serviceable and non-replaceable. When LED light bulbs burn out in this type of fixture, the complete light must be replaced. Replacement bulbs or light fixtures are available for purchase through the Newmar Parts Department.

⚠ WARNING

Do not substitute bulbs just because they will fit, as it may cause overheating, back feed, or damage to the light fixture or lens.

Exterior Lights

Replace any exterior light bulbs or fixtures as needed to maintain DOT safety requirements. When servicing interior or exterior lights, make sure you replace any light bulb with the same bulb number (normally stamped on the base of the bulb or printed on the bulb). Replacing the bulb with the identical part number will ensure the wattage and base are the same.

The coach may have headlights installed that are atmospherically vented, so condensation may occur in these headlight assemblies. Under normal driving conditions with the headlights turned on, the condensation will dissipate, allowing it to escape through the vent.

⚠ IMPORTANT

Always check the operation of all headlights, turn signals, and clearance lights prior to traveling.

It is necessary to keep exterior lights clean, as dirty lights have diminished output and reduced visibility. To clean your exterior lights, use a mild soap designed for automotive car washing. Avoid using harsh cleaners, abrasive products, and petroleum-based products or other chemicals.

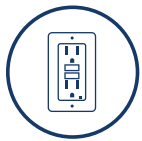

Receptacles and Accessory Chargers

Newmar coaches are framed 16 inches on center, allowing the best placement of outlets, switches and other components.

120 Volt Outlets

This article provides information about the 120 Volt outlets located throughout the interior of the coach.

Several 120 volt receptacles are located throughout the interior of the unit. These receptacles require three-pin plugs that provide proper grounding to protect you from electrical shock. The breaker for the outlets are usually located in the breaker box. If the breakers are on the inverted circuitry, they will be located in the subpanel near the main breaker box.

**⚠ IMPORTANT**

Do not use an adapter, cheater, or extension cord that breaks the continuity of the ground circuit to the ground pin. Never remove the ground pin from a plug in order to connect it to a two-pronged ungrounded outlet.

Ground Fault Circuit Interrupt Outlets (GFCI)

This article provides an overview of the purpose and function of a GFCI outlet.

The Ground Fault Circuit Interrupt (GFCI) outlets protect the user from ground faults between a hot wire and ground. The 120 Volt electrical outlets in the kitchen and bath area are GFCI protected receptacles. The electrical outlets located in the slideouts are wired through the kitchen GFCI.

The exterior electrical outlets are wired through the bathroom GFCI. On units equipped with the floor heat option, a separate GFCI is installed in the bathroom or near the main breaker box. Units with the holding tank heat pad option will have an additional GFCI located in the basement area; however, the exact location varies.



The GFCI outlets should be tested at least once a month. The 120 Volt electrical system must be energized in order to test the GFCI. The reset button needs to be pressed before starting the test. Then push the test button, which will cause the reset button to pop out, confirming the protected circuits have been disconnected. Push the reset button again until a click is heard to reactivate the protected circuit. If the GFCI is working properly, the reset button will remain in the "IN" position. If an item plugged into a Slideout or outside receptacle is not working, check for a tripped GFCI in the kitchen or bathroom. Likewise, if the floor heat or holding tank heat pads are not working, check the GFCI for that circuit.

⚠ WARNING**The GFCI will not reduce the shock hazard if the short is between a neutral and hot wire or two hot load wires.**

USB Outlet, Auxiliary Input, and 12 Volt Receptacle Overview

This article provides a functional overview of the USB outlet, auxiliary input, and 12 volt receptacles in a coach.

USB Outlets

USB outlets may be located in various places throughout the coach. The number of ports may vary. The USB outlets are for charging only and are not connected to any entertainment equipment. They simply provide convenient accessory charging without filling your 120 volt outlets with chargers. Most USB outlets require 120 volt power when located outside of the cockpit area of the coach.



Auxiliary Inputs

USB ports labeled with auxiliary input are normally connected to the dash radio and allow input to the radio via USB and or 3.5 mm cable. Refer to the owner's guide for the radio for information about selecting auxiliary inputs.



12 Volt Receptacles

Your coach maybe equipped with one or more 12 volt receptacles conveniently located in the dash area. These 12 volt receptacles allow you to plug in a variety of 12 volt DC accessories, including cell phone battery chargers, camera battery chargers, etc. These are fused at 20 amps.



Solar Power

This article provides basic information about the solar panels that may be installed on the coach.

Solar Power Overview

If your coach is equipped with a 5 or 10 watt solar panel, it charges the chassis batteries when exposed to sunlight. Larger solar panels (optional equipment on select coaches) may also charge the house battery bank.

The solar panel is regulated to charge automatically and should be cleaned as needed for the most efficient light absorption. The following is an example of how the system may charge the batteries based on battery voltage. For example, if the chassis batteries are above 12.7 volts direct current, the solar panel may provide less charge.

- 12.7 Volts = 100% of Battery Charge
- 12.4 Volts = 75% of Battery Charge
- 12.2 Volts = 50% of Battery Charge
- 12.0 Volts = 25% of Battery Charge
- 11.9 Volts = 0% of Battery Charge

⚠ IMPORTANT

It is important to note that the system may not indicate a charge any time it is exposed to sunlight. The built-in "regulator" will only allow the system to charge the chassis batteries when their voltage is low.

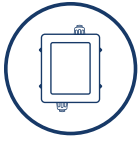

Transfer Switches and Surge Protectors

This article provides an overview of the transfer switch and the integrated surge protector. The transfer switch allows your coach to be powered by more than one power source, while only allowing one active power source connection at a time. When the generator is turned on, this switch automatically transfers to generator power. Surge protection was used on select coaches to protect the coach from power surges during storms and poor shore power conditions from the incoming shore power connection. Today, most transfer switches have integrated surge protection.

⚠ WARNING

Due to the risk of electrical shock, service should be performed by a qualified electrician or authorized service technician. The electrical system may have multiple 120/240 volt power sources. All power sources must be turned off, and any auto generator start features must be disabled prior to servicing.

There will be a slight delay between the start of the generator and the electrical connection. This delay allows the generator to reach normal operating speed without needing to supply a required load. When the unit is plugged into shore power, an audible click will be heard in the transfer switch box. The sound is normal and indicates that the relay inside the transfer switch is engaging the outside power source.



ELECTRONICS

Multiple coach functions can be controlled at the tips of your fingers, including surveillance and security, lighting, holding tank monitoring, and if equipped, the total coach management system.

⚠ NOTICE

For detailed information, see the owner's manual for the specific item or refer to Newgle. Audio-Visual Equipment information is located in the Entertainment Systems category.



Cameras and Video Monitoring Systems

This closed circuit television system features cameras mounted on the exterior of your coach and is connected to the in-dash video screen. This system comes on automatically when you put the transmission in reverse to allow you to see behind your unit when backing up. Additionally, it can be manually turned on in transit to allow you to monitor your towed vehicle or for additional assistance in passing maneuvers.

Voyager Rear View Camera Operation (AOM713)

This article provides basic operation instructions for a Voyager Rear View Camera (AOM713).

⚠ IMPORTANT

These brief operation instructions are for quick reference only and should not take the place of the complete manual(s) provided by this product's manufacturer. Refer to the corresponding links and files in Newgle for more details about your product.

Control Panel



1. Power Button: On/Off
2. Menu: Brightness, Contrast, Color, Tint
3. Select: Input Source Select/Menu Option Select
4. Down: Decrease Controls/Menu Navigation
5. Up: Increase Controls/Menu Navigation
6. Day/Night: Mode Setting
7. Volume - : Speaker Volume Control/Menu Option Setting Selection
8. Volume + : Speaker Volume Control/Menu Option Setting Selection

Operation

Use the **Menu Button** to open and toggle through the screen setting adjustments. While in the screen setting mode, use the up and down arrows to adjust the setting.

- Brightness
- Contrast
- Color
- Tint

Use the **Select Button** to select the camera you want to display.

- Right Camera
- Left Camera
- Rear View Camera

⚠ NOTICE

When the transmission is in reverse, the camera select is overridden, and the monitor will display the rear view camera.

Rear View Camera Use the **Day/Night Button** (sun icon) to adjust the screen back-lighting.

- Day
- Night
- Auto

Use the **Volume Buttons** (+/-) to increase and decrease the sound from the rear camera microphone. As the coach is traveling down the road, this microphone will pick up wind, engine, and road noise. To avoid listening to it, keep the volume setting low.

- Refer to the Voyager owner manual for additional functions and setup instructions.

Source: Voyager AOM713 Camera Monitor Owner's Manual

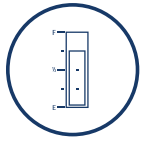

Holding Tank Monitoring Systems

The monitor panel allows you to check the approximate levels in the fresh, gray, and black water holding tanks, as well as propane levels (if equipped), and the battery condition. The monitor panel is generally located in the front overhead cabinet, or above or near the entrance door. An additional monitor panel may be located in the basement water compartment.

Precision Circuits Holding Tank Monitoring Systems Operation (Digi-Level)

This article provides basic operation instructions for a Precision Circuits Digi-Level Holding Tank Monitoring System.

Overview

The monitor panel allows you to check the approximate levels in the fresh, gray, and black water holding tanks, as well as propane levels (if equipped), and the battery condition. The monitor panel is generally located in the front overhead cabinet, or above or near the entrance door. An additional monitor panel may be located in the basement water compartment.

The Digital Monitor Panel digitally displays the levels of the Water and Waste Tanks, and L.P. Tank. It provides both a digital and analog Battery Volt Meter.

To conserve battery power, after one minute, the backlighting will turn off, and the display will return to a default screen. However, the panel is still live. Touching the button will display the level and also turns on the backlighting again.

Digi-Level Screens

TANK LEVELS SCREEN

Press the “Levels Check” button to check the tank level statuses. The levels will show on the digital display.

The screen will continually update every second, and the level sensors are continually communicating. Should a sensor exceed normal limits, “ERR” will display in place of the level. Depending on the RV, the levels will be displayed in either 1/3's or 1/4's.

- E, 1/3, 2/3, F, or ERR; or
- E, 1/4, 1/2, 3/4, F, or ERR.

VOLTAGE SCREEN

The chassis and house battery voltages will display in both digital and analog (bar graph) format. The analog range is 10.0 volts to 15.0 volts, with bar graph meter increments of 0.125 volts. The screen will continually update every second. Below are some guides to determine the battery charge state:

- Over 13.0 volts, the battery is being charged.
- If no appliances, lights, Inverter, etc are on, a battery at rest voltage will have an approximate battery charge state range from 11.8 volts (0% charge) to 12.8 volts (100%).

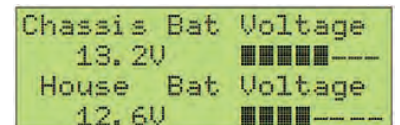
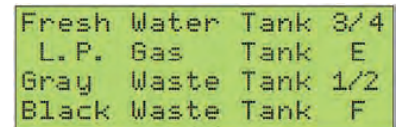
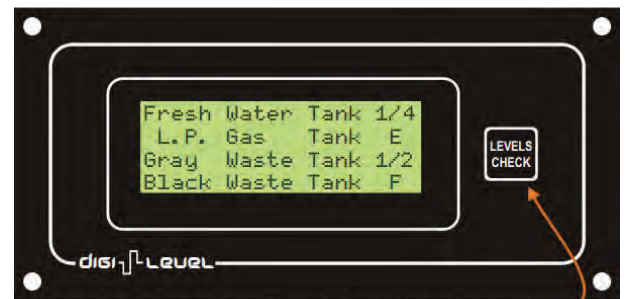

GENERATOR SCREEN

The display will show the status of the generator:

- Running
- Stopped
- Hour Meter (if installed by the OEM)

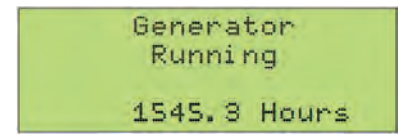

Tank Sensor and Calibration

The tank sensor features field effect technology, a non-invasive method. Each sensor array contains three sensors which glue externally to the polymer tank wall with high-grade, long-life adhesive, at the position and level that the water is to be sensed, thus eliminating the need for calibration.

Each sensor emits an electric field into the tank. When the water level passes by the sensor, it detects a change in its electric field.

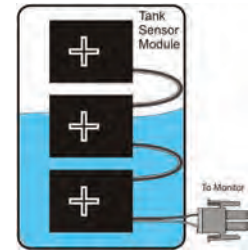

Automatic Learn Feature and Resetting The Panel To Default

The Digital Monitor Panel has two automatic learn features and it will learn if the water and waste tanks have 1/3 or 1/4 increment sensors and if the LP sensor exists. Each feature is learned independently, even for the individual tanks. Once a feature is learned, it is stored in non-volatile memory, and remembered even if battery power is removed from the panel. The Digital Monitor Panel has many safe guards to prevent improperly learning a feature. Should the panel learn something incorrectly, an option exists on the panel to reset the original factory default, so that the panel can re-learn the proper features.

TANK LEVELS SCREEN

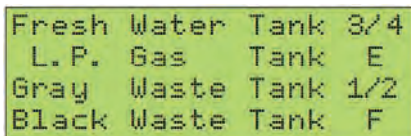

1. Touch the “Levels Check” button as many times as needed to get to the Tank Levels screen.

VOLTAGE SCREEN

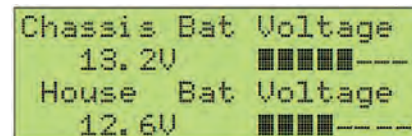

2. Press and hold the “Levels Check” button for approximately six seconds. The Voltages screen appears right away, but continue holding the button.

FACTORY MODE SCREEN

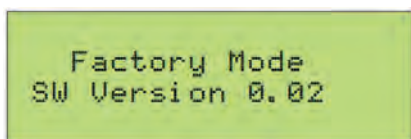

3. Once Factory Mode screen appears, release the “Levels Check” button, and quickly press and release again.

FACTORY RESET SCREEN

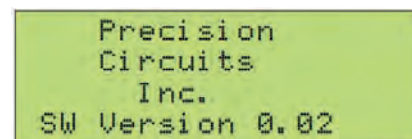

4. If done properly, the Factory Reset screen should appear. Factory Default settings have been reset, and the panel will go through the power-up screen. If not, go back to step one, and repeat the process.

Performing A Levels Check

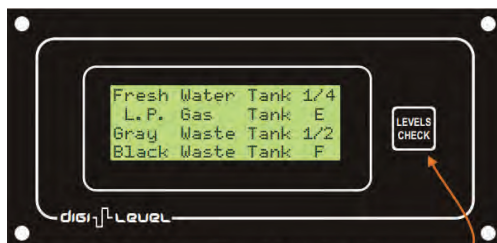

Pressing this button will scroll through the multiple info screens

For coaches not equipped with the SilverLeaf system, simply press the “Levels Check” button to check the tank level statuses. The levels will show on the digital display.

Monitor Panel Calibration

The monitor panel has been calibrated for accuracy prior to leaving the factory and should not need to be adjusted. In the event that the system does not read accurately, then re-calibration may be necessary. Follow the manufacturer’s procedures for re-calibration for your specific product. It is recommended to have a qualified service technician perform the re-calibration procedure.



Navigation System

Your coach may be equipped with a GPS based Navigation system. This system uses GPS technology to guide you through maps and information for traveling assistance. It features voice prompts and touchscreen technology to make scrolling through the menus and getting information incredibly easy.

⚠ WARNING

The navigation system is NOT intended to replace, supersede, or take precedence over any traffic signs, street signs, hazard signs, etc.

The navigation feature is intended to assist you with guidance to your destination. The system may need software and map updates. Updates are not warrantable issues, as roadways change over time and construction takes place, the maps and/or systems may become obsolete.

⚠ CAUTION

It is the driver's responsibility to make sure the roads are safe and appropriately navigated and roadway weight limits and clearances are rated for the vehicle you are driving.

Rand McNally Navigation Operation via Xite Infotainment System (XSG2)

This article provides basic operation instructions for a Rand McNally Navigation via Xite Infotainment System (XSG2).

⚠ IMPORTANT

These brief operation instructions are for quick reference only and should not take the place of the complete manual(s) provided by this product's manufacturer. Refer to the corresponding links and files in Newgle for more details about your product.

Overview

This Quick Start Guide is intended to provide basic instructions to begin using your Infotainment Center. Failure to properly focus on the operation of your motor vehicle can result in death, serious injury and property damage. The Infotainment Center should never be used at a time or in a manner that distracts you from properly focusing on operation of the motor vehicle in which it is installed.

⚠ IMPORTANT

Please review all disclaimers, warnings and detailed operating instruction in your Xite Owner's Manual prior to using your Infotainment Center.

Hardware Buttons

1. Bluetooth Microphone
2. PWR: Press to enter/exit standby. Press and hold to MUTE.
3. MODE: Press to access Main Menu.
4. DIM: Press to increase screen brightness. Changes saved for both day/night modes.
5. VOL +/-: Press to adjust volume.
6. Favorite Source Hot Key
7. NAVI: Press to enter/exit navigation display. Press and hold to only hear navigation prompts (mutes current audio source).
8. EJECT: Press drop down screen for access to optical drive.
9. IR Receiver for Remote Control Operation



Header Information

1. To access the Main Menu or change screens, tap source ICON in the top left corner.



2. Select a new media source. Audio from current source will continue to play during navigation or camera video display.
3. Select AUX ZONE to change display source on 2nd monitor output.



4. Select Settings to change system/source options. To change source settings, go to the audio source you wish to change then go into settings. Select the source on the bottom right.
5. Touch Page Number to go to next SETTINGS page.



Source Quick Tips

RADIO

Tap **AS** button to Auto Store 6 Pre-sets of the available Radio Stations in your area.

IPOD

Connect your iPod/iPhone using your USB/iPod cable to listen to audio tracks on you Apple device.

- Use the control buttons and Menu to find tracks/playlists. Tap your selection.

SIRIUSXM

A subscription is required to enjoy SiriusXM Satellite radio. Please see your SiriusXM Owner's Manual or go to www.siriusxm.com in Canada www.xmradio.ca) and click **ACTIVATE RADIO**.

FEATURES OF SIRIUSXM (SXV200 TUNER)

- **Replay:** Press **Replay** to listen up to 1 hour of previous audio on your current channel (may vary by tuner model).
- **Song/Artist Alerts:** Store up to 50 of your favorite Songs and Artists. Tap **FUNC > ALERT±**. You will be notified when saved alerts are playing on other channels.
- **Song/Artist Alerts:** Store up to 50 of your favorite Songs and Artists. Tap **FUNC > ALERT±**. You will be notified when saved alerts are playing on other channels.
- **My Favorites:** Create your own virtual category of your favorite channels. Tap **CAT+** to save the current Channel as a favorite. To use **MY FAVORITES** Category, Tap **CAT** and Scroll down to **MY FAVORITES** and Tap. Choose a Channel.
- **Automatic Mature Channel** and User defined **Channel Locking**. Please see Owner's Manual.

ON-SCREEN MANUAL CAMERA SELECTION

Tap Camera Icon to go to Manual Camera view. Tap screen center to bring up camera icons. Tap the camera you wish to view. To hear Rear Camera Audio tap the Speaker icon.

DVD/CD/USB

Insert your disc or USB device and use the on-screen controls to enjoy your media.**

WIFI

Wi-Fi ready. Connect to Rand McNally weather/traffic premium services. Internet access required.

- * Pending device limitations from your phone/hardware manufacturer. Please see individual device manuals.
- ** Please see Owner's Manual for a full list of supported file and disc formats.

BLUETOOTH

To connect you phone Tap **NEW** button and follow your phone prompts and instructions. After connection you can:

- Make Hands Free Calls
- Download your phonebook form you cell phone*
- Listen to your stored audio tracks*
- Stream and control audio from many of today's popular Apps using the audio controls on-screen*

For Support

Refer to Newgle for more information, or contact:

RIVERPARK INC.

- Website: www.riverparkinc.com
- Email: navi@riverparkinc.com
- Phone: 800-422-7717

RAND MCNALLY

- Website: www.randmcnally.com/support
- Phone: 800-333-013

XITESOLUTIONS NORTH AMERICA INC.

- Website: www.xsna.ca
- Email: support@xsna.ca

Source: XSG2NA-X2 Infotainment System with Rand McNally RV GPS (2015)

Rand McNally SD Card Update with the Rand Dock Application

This article provides basic operation instructions for updating a Rand McNally (navigation system) SD card with the Rand Dock Application, as provided to Newmar by Xite Solutions on March 15, 2019.

NOTICE

The Rand McNally Dock application is required to perform the update process, as well as an internet connected computer with an SD card port or Card Reader.

IMPORTANT

Before attempting this procedure, please read this document fully to ensure correct step-by-step process. This process requires the most up-to-date version of Rand Dock to complete.

Updating via Pc

1. Remove your Rand McNally SD card from the Xite radio.

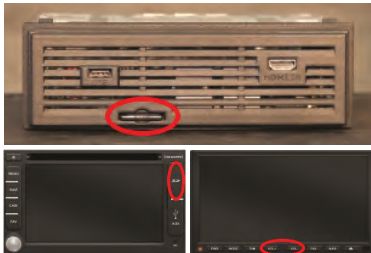

2. Download the Rand Dock Software (<https://www.randmcnally.com/support/s/dock-software>). Be sure your machine meets the requirements.

NOTICE

.net Framework for Windows may need to be installed. You must also have a functioning SD Card Reader available.

3. Install the software to your computer.
4. Insert the Rand McNally SD card into your SD Card Reader.
5. If you receive a Defective Card warning, please follow the on-screen instructions.

 Your SD card may be part of a batch of SD cards that were known to have defects. You may be eligible for a free replacement SD card. Please contact Rand McNally Customer Support at 1-877-446-4863 to confirm. If a replacement is necessary, you will be provided instructions on how to receive this at no cost.

6. Open the Rand Dock software (if it is not already running) and fill in the registration information. This will not be required if you have already registered with the software. When complete, click the Submit Icon.



7. Click the OK button.

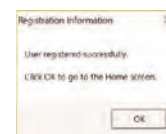

8. Select the Register for Lifetime Maps option. This option will not be available if you have already registered with Rand McNally and is normal.

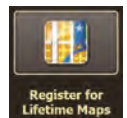

9. Click the Submit button.

Click submit to register the connected device for Lifetime Maps
Submit

10. Click the OK button.

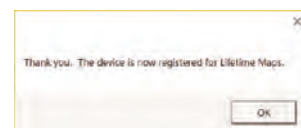

⚠ NOTICE

If your device is already up to date, this will show “Your Device Is Up To Date.” See step 18.

11. You will be returned to the main screen.
12. Click the Map Update Available option.

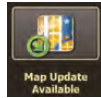

13. Click the Begin Download button.

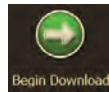

14. This is a large download and may take some time.



15. When complete, click Install Update.



16. The update will now transfer to your Rand McNally Card.



17. When complete, hit the Back button Arrow icon in the top left corner.



18. You should now see “Your Device Is Up To Date.”



It is suggested that you synchronize your Rand McNally SD card before each trip to maintain the most recent information, including construction data, etc. This is done by clicking the Update Available option when the card is inserted while the Rand Dock is running.



Updating via Mac

1. Remove your Rand McNally SD card from the Xite radio.

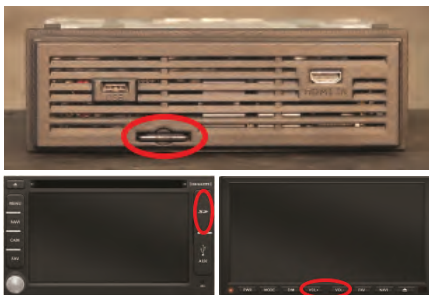

2. Download XQuartz (<https://www.xquartz.org/index.html>)



3. Install XQuartz. Select OK to allow it to become the X11 Server.

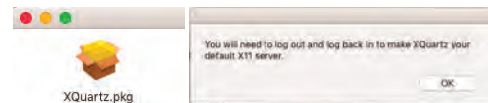

4. Restart Mac OS.

5. Insert Rand McNally SD card into SD reader.



6. Download the Rand Dock Software (<http://ndrepo2.randmcnally.com/dockinstaller/mac/SetupRMDock.pkg>). Be sure your machine meets the requirements.

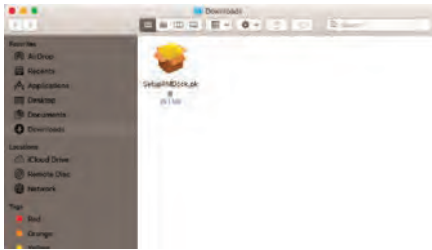

7. Install Rand Dock.



8. Restart Mac OS.

9. Start Rand Dock (this may take up to a minute).



10. If you receive a Defective Card warning, please follow the on-screen instructions.

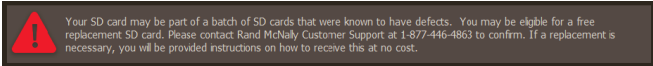

11. Select the Register for Lifetime Maps option. This option will not be available if you have already registered with Rand McNally and is normal.



12. Click the Submit button.

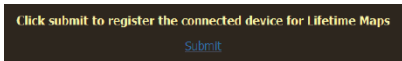

13. Click the OK button.

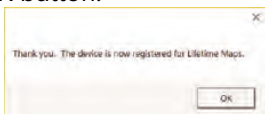

14. You will be returned to the main screen.

15. Click the Map Update Available option.

NOTICE
If your device is already up to date, this will show "Your Device Is Up to Date." See step 21.

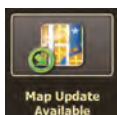

16. Click the Begin Download button.

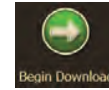

17. This is a large download and may take some time.



18. When complete, click Install Update.



19. The update will now transfer to your Rand McNally Card.



20. When complete, hit the Back button Arrow icon in the top left corner.



21. You should now see "Your Device Is Up To Date."



It is suggested that you synchronize your Rand McNally SD card before each trip to maintain the most recent information, including construction data, etc. This is done by clicking the Update Available option when the card is inserted while the Rand Dock is running.





WiFi Systems

Due to the ever-growing demand of internet connectivity, a WiFi system in your coach can mean the difference between using costly mobile data and being able to access free WiFi wherever your travels may take you. Your coach may be equipped with one of the many options WiFi systems Newmar offers.

WiFi Ranger Router Operation (SkyPro LTE, Sky3 Pack, SkyPro Pack)

This article provides basic operation instructions for a WiFi Ranger Router (SkyPro LTE, Sky3 Pack, SkyPro Pack).

WiFi Ranger Product Introduction

The goal of WiFiRanger products is to enhance existing internet sources and make them more usable, while also connecting to these internet sources as desired for the most speed, reliability, and automatic backup. WiFiRanger products can reach weak WiFi at extreme distances and also tether to your USB MiFi, Aircard, or Smartphone. WiFiRanger can also simultaneously utilize these multiple internet sources by load balancing data for maximum speed and reliability.

SIMPLIFIED COACH NETWORK

All networkable electronics within the RV can be connected to the WiFiRanger for seamless interconnectivity and control of these devices by the customer.

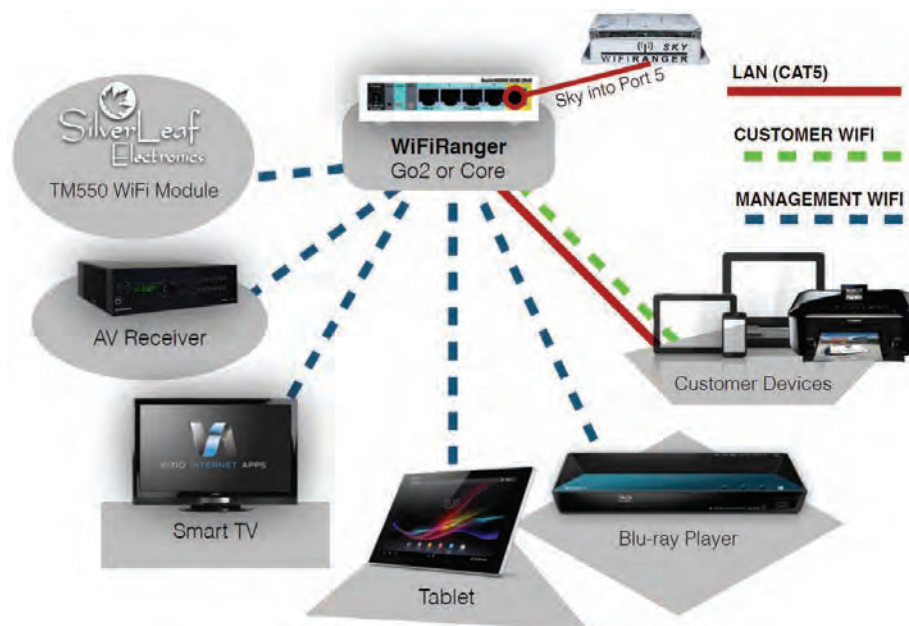

LONG-DISTANCE WIFI RECEPTION

Initially designed for extreme wireless range, WiFiRangers are able to reach weak WiFi Hotspots that RVers would otherwise struggle to connect with. This gives customers the ability to keep online more reliably while staying at various RV Parks and Resorts.

CLOUD-BASED REMOTE CONNECTIVITY

Once connected to the internet through public WiFi or customer's 3G/4G device, WiFiRangers can provide cloud-based remote connectivity to the OEM manufacturer for troubleshooting networked devices and A/V components. This remote support and diagnostics is invaluable as it can prevent a service appointment, saving time, money, and improving customer opinion.

Control Panel

The interface used to setup and control a WiFiRanger router. Each WiFiRanger has its own Control Panel that is embedded within the router and accessed in a web browser of a connected device. Computers, smartphones, tablets, and other devices with web browsers can be used to setup and control a WiFiRanger.

By default, advanced features are hidden on the Control Panel. Turn Hide Advanced Features to Off on the Setup tab to view the full Control Panel. Most users only need the simple mode.

- Web Browser Based
- Accessible by All Devices
- Simple and Clean Design

Quick Start

1. Power WiFiRanger: Use included power supply or follow WiFi Ranger’s installation guide
2. Wait a couple minutes: WiFi Rangers automatically search for internet after powering up
3. Wirelessly connect a device to Network using Password; You can also connect via hardwire for WiFi Rangers with LAN ports.
4. Open devices web browser and go to Control Panel: Open Internet Explorer, Chrome, Firefox, Safari, etc.
5. See if WiFi Ranger is online or connect: Join a WiFi network or connect to ethernet WAN or Cellular if not yet online.



Basics

BOOKMARK

Upon accessing the Control Panel, it is highly recommended to create a bookmark using the Make Bookmark link located at the bottom left of the Control Panel. This makes accessing the WiFiRanger easy in the future while alleviating the need to remember the direct IP address.

Bookmark Hotkeys: Command+D (Mac) / Control+D (Windows)

SCAN & CONNECT TO WIFI SIGNALS

1. Get on Main tab of Control Panel. Everything necessary is located on the left-hand side.
2. Select desired wireless radio. Only WFRBoost & WFRControl users have multiple choices as shown.
3. Click Scan. Refreshes the list of WiFi networks which the selected radio can currently see.



4. Click connect on desired WiFi Network once Scan is complete. You will be prompted for the password if the WiFi Network was secured using WEP or WPA.

	14 WiFi Networks	Signal	Type	Speed	Tag
CONNECT	BlueMeshNetworks	n [signal strength]	WPA		<input type="checkbox"/>
CONNECT	Pub.WiFiRanger.7226	n [signal strength]	OPEN		<input type="checkbox"/>

The Scan button performs a one-time refresh of the wireless signals in range. When moving locations, for instance, the list of WiFi Networks may look like you are still at the old location, but clicking the Scan button will list what is currently available. Keep in mind that you must first select the desired model to the left of the Scan button prior to scanning or connecting. Generally, it is best to select the outdoor unit which will be positioned to the right of the indoor unit's radial button. With 2.4 / 5.8GHz capable products released starting in 2016, you will also have the option to switch between the 2G or 5G receiver. It is likely that the 5G receiver will not see as many networks as the 2G because 2.4GHz is currently the most popular frequency use for WiFi Hotspots.

The Connect button simply attempts to connect to the selected WiFi Network. If the signal is secured, you may be prompted to enter the password of the WiFi Network. The WiFi status will update with the steps the WiFiRanger is taking during the connection attempt.

Newmar Setup Processes & Specifications

CONNECTING TO INTERNET

In order to connect the WiFiRanger to a WiFi network for internet access to the whole WiFiRanger system, get on the Control Panel of the indoor WiFiRanger then perform the following:

1. Select Sky / Sky2 / SkyPro to left of Scan button on Main tab (powerful outdoor unit)
2. Click Scan to refresh list of WiFi networks in area
3. Click Connect to left of desired WiFi Network (enter password if prompted)

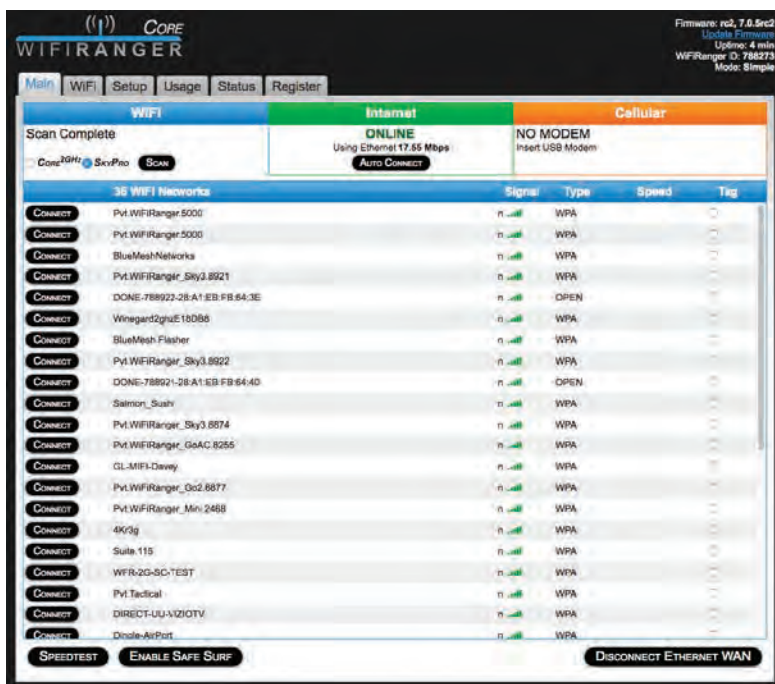

Sources: WiFi Ranger's Website ; WiFi Ranger Newmar Service School Training (2017); WiFi Ranger User Manual Revision 11; WiFi Ranger Product Tutorial for Newmar Motorcoaches: <https://www.youtube.com/watch?v=v8-yk3B7Ngc>

Wineward In-Motion WiFi System Operation (Connect 4G1)

This article provides basic operation instructions for a Wineward In-Motion WiFi System (Connect 4G1).

IMPORTANT

These brief operation instructions are for quick reference only and should not take the place of the complete manual(s) provided by this product's manufacturer. Refer to the corresponding links and files in Newgle for more details about your product.

Setting Up The Winegard Connect 4G1

NOTICE

Winegard recommends using Chrome or Firefox browser for set-up.

1. Turn on the WiFi enabled device that you want to connect and scan for wireless networks with this device.
2. The label located on the front of this manual or on the back of the IDU will display the default SSID and password. Select WiFi signal and connect. Once the IDU has been selected, enter the password.



3. Once connected, open an Internet browser and type 10.11.12.1 into the address bar and press Enter.

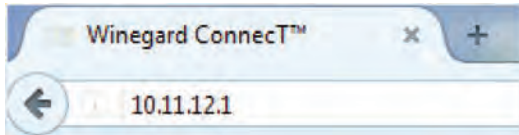

This will take you to the Status Screen for the IDU. Login using:

- Username: admin
- Password: admin

The Winegard Connect 4G1 can access the Internet two different ways: from a local WiFi network or a 4G/LTE network.

4. To connect to a 4G/LTE network, select 4G/LTE Only from the Internet access menu. Then click SELECT.

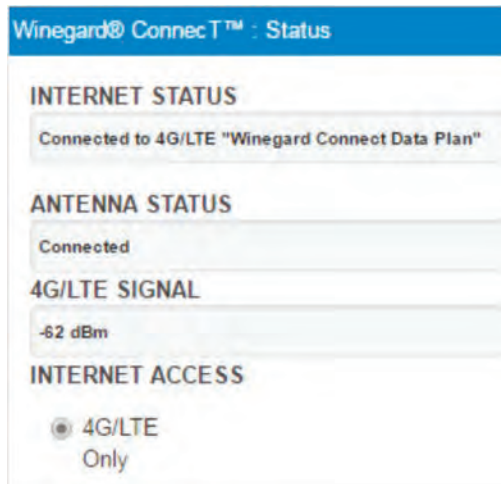

WARNING

Connecting to the Internet through 4G/LTE will use data from your Winegard Connect Data Plan.

5. To add data to the 4G1 from the status screen, choose DATA PLAN from the drop down menu and click SELECT. Once on the data plan screen, you can see how much data you have remaining or click the link to shop.winegard.com and follow the steps.

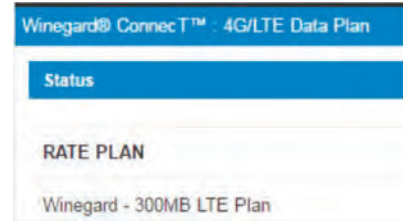

WARNING

In order to get to shop.winegard.com you must be connected to an internet source.

6. To connect to a WiFi network, select SCAN FOR AVAILABLE WiFi to bring up a list of all WiFi signals in range (this could take a few minutes). The Winegard Connect 4G1 will display available networks by signal strength. Select the desired network and click CONTINUE.

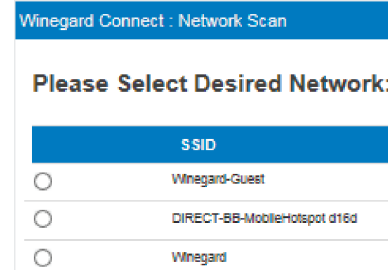

7. Enter the network password, if prompted. Once the Winegard Connect 4G1 connects, the status screen will display the page shown in Figure 6. When INTERNET STATUS shows connected to the chosen network, (this could take as long as two minutes) the system is ready to browse.

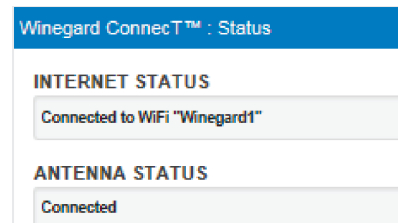

NOTICE

When connecting to a network requiring a splash screen for multiple days, it may be necessary to clear your browser cache.



ENTERTAINMENT SYSTEMS

Newmar partners with the most prestigious names in mobile lifestyle, entertainment and technology.

These brands are leaders in their fields – and legends in providing customers with new, unsurpassed levels of quality and reliability. Best in class performance from names you can trust. Stay entertained on the road and off, with spectacular visual and sound options from industry leaders. This section provides information on entertainment components, including televisions, dash-mounted audio equipment, multi-disc players, home theater systems, and satellite antennas. Such components may be located within your coach’s living room, bedroom, cargo area, or even outside of your unit in an optional exterior entertainment center.

⚠ NOTICE

Some of the components are optional and may not be installed in your coach.



Antennas, Cable, and Satellite Systems

Antennas, Cable, and Satellite System Overview

This article provides an overview of the antenna, cable, and satellite system in the coach. Your unit may be equipped with an exterior antenna jack and interior antenna jacks or wiring at each television location. Depending on your coach year, model, and options, several antennas have been used.

Antenna Power Booster

An antenna with a power booster may be installed in your coach and is designed for reception of all local color and black-and-white channels. The antenna may be automatic, stationary, or manual lift. The power booster supplies voltage to the antenna when using over-the-air signal. However, it transfers the connection from the antenna to park cable when it is available and connected.

Over-The-Air Signal

If the reception is poor, make sure the power switch for the power booster is in the “ON” position and all of the coax connections are tight. This switch is usually located beside the passenger chair or on the video selector box (select units only). On coaches with a Rayzar automatic TV antenna, this switch is integrated into the power on/off switch typically located in the overhead control center. After traveling, it may be necessary to auto-program your televisions to pick up local stations.



Cable Connection

An exterior cable jack and receptacle may be available on your coach. If installed, they may be located in an outside storage compartment, usually near the power cord. When using park cable, it is necessary to turn the antenna booster off in order to allow the signal to travel to the television or selector switch (if equipped). This switch is usually located beside the passenger chair; it can also be the power button on the video selector box (select units only). On coaches with a Rayzar automatic TV antenna, this switch is integrated into the power on/off switch typically located in the overhead control center.

⚠ IMPORTANT

Failure to turn off the power booster switch to the antenna while using the park cable system may cause poor picture quality.

Winegard Sensor Manual Antenna Operation

This article provides instructions for raising, lowering, and rotating the Winegard Sensor Manual Antenna, as well as information about the booster switch and cable mode.

⚠ IMPORTANT

These brief operation instructions are for quick reference only. Any quick start instructions provided should not take the place of the complete Operation Manual provided by this item’s manufacturer.

Newmar is currently using Winegard antennas. Depending on your coach model, year, and available options, your coach may be equipped with either a manual or an automatic TV antenna.

Operation

RAISING THE ANTENNA

Turn elevating crank (clockwise) in “UP” direction about 13 turns or until some resistance to turning is noted. **AMPLIFIED MODELS ONLY** Turn power supply ON to use either front or rear TV outlet. Neither outlet will work unless power supply switch is ON.



LOWERING THE ANTENNA

Rotate antenna until pointer on directional handle aligns with pointer on ceiling plate. Turn elevating crank (counter clockwise) in “DOWN” direction about 13 turns or until resistance is noted. Antenna is now locked in travel position.

⚠ CAUTION

Under no circumstances should you lower the antenna in any position except the travel position.

ROTATING THE ANTENNA FOR BEST PICTURE

Make sure antenna is in “UP” position. Pull down with both hands to disengage ceiling plate. Rotate for best picture.

Booster Switch

On coaches equipped with a manual antenna, the booster switch is typically located beside the passenger seat on the wall near the floor (left photo).



Cable Mode

When the control panel is powered off, park cable signals will be passed to the television. In this mode, the LED indicator light is off.

Source: Winegard Sensor Antennas Installation/Operation Manual (All Models)

Winegard Automatic In-Motion Roof-Mounted Satellite TV Antenna Operation (RoadTrip)

This article provides basic operation instructions for a Winegard Automatic In-Motion Roof-Mounted Satellite TV Antenna (RoadTrip).

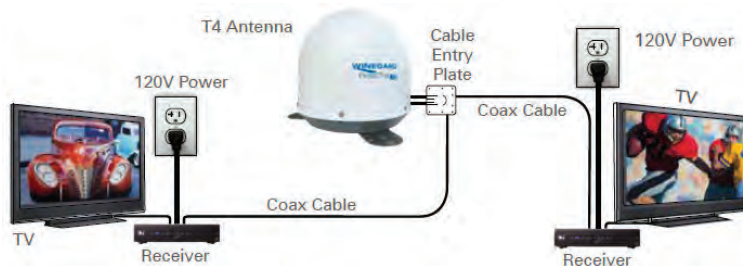

The RoadTrip® T4 antenna switch settings are preset for DIRECTV. If you have a DISH or Bell TV receiver, you must change the numbered switches found on the electronics box under the dome.

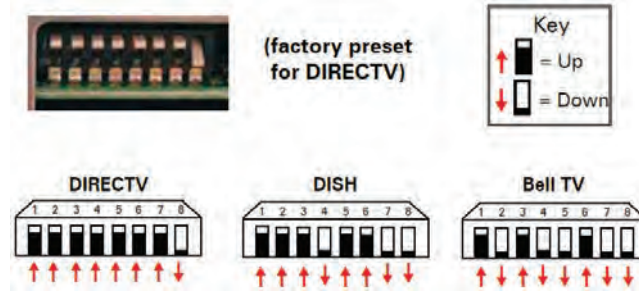

Dish®

RECEIVER SETUP

If using two DISH® receivers with the RoadTrip® T4 antenna, both receivers must be configured off of the primary port. Check out online receiver setup guides for your antenna at www.winegard.com/support.

RECEIVER RECOMMENDATIONS

The RoadTrip® T4 antenna will operate with most DISH receivers. Winegard does not recommend using receivers with hard drives, as they are not intended for mobile applications. Winegard recommends using a single tuner DISH receiver.

SATELLITE COVERAGE

The antenna will locate and toggle between satellites 110°, 119° and 129° in Western Arc Mode. The T4 antenna will not operate in all areas where satellites 110°, 119° and 129° are available. Satellite coverage maps are based on level, stationary operation. Reception interruption may also occur during adverse weather conditions.

DirectTV®

RECEIVER SETUP

Connect the receiver to a power source, and complete receiver setup. Check out online receiver setup guides for your antenna at www.winegard.com/support.

RECEIVER RECOMMENDATIONS

The RoadTrip® T4 antenna will operate with most DIRECTV receivers. Winegard does not recommend using receivers with hard drives, as they are not intended for mobile applications. Winegard does not recommend using an HD receiver since HD programming will not be available. SWM only receivers require a SWM-840 kit.

SATELLITE COVERAGE

The antenna will locate and toggle between satellites 101° and 119°. The RoadTrip® T4 antenna will not operate in all areas where satellites 101° and 119° are available. The T4 antenna is not compatible with 110° or KA-band satellites 99° and 103°. Satellite coverage maps are based on level, stationary operation. Reception interruption may also occur during adverse weather conditions.

Operating The Roadtrip® T4 Antenna

1. Turn on receiver and television set. The RoadTrip® T4 antenna must be connected to a receiver plugged into 120VAC.
2. Verify that you are getting the receiver's menu screens on the television. These screens are available with or without the dish finding the signal.
3. Ensure receiver is properly configured for your provider.
4. Turn the power switch on for the antenna. Within 10–15 seconds, the dish will begin moving and should make one or two revolutions during startup. During this process, it is normal to hear a slight grinding sound as the unit checks its rotational limits. This does not harm the unit. The system will pause to acquire GPS.
5. Once the dish begins its search, it pauses on signals long enough to determine which satellite it has found. The antenna may move off the signal in an effort to verify the signal and should return shortly.

TIP: Because the T4 antenna uses information from the last location where it was on signal, satellite acquisition may take longer if the dish is inactive over long distance traveling.

6. After the T4 has verified the correct satellite, it will continue to track the signal. The unit will go into "Sleep Mode" if the vehicle is stationary for 6 minutes. This involves a quick verification process where signal may be lost, then return to the signal and be silent. If the vehicle begins moving greater than 10 MPH, the in-motion T4 will resume tracking mode. For smoother operation, use your on-screen guide to locate your channel rather than "channel surfing."

- NOTE There are certain areas within the U.S. where the T4 antenna may experience limited or no coverage of the 129° satellite for HD programming. DISH home coverage has the same limitations. Problem areas include Washington, Oregon and California, but limited coverage may extend past these areas. Contact DISH for additional coverage questions (1-888-825-2557).
- ALSO when the T4 dome is blocked (example: while going through a tunnel, under a bridge, by a building, etc.) programming will not be available. Once the block is removed, the programming will return.

Maintenance

The RoadTrip® T4 antenna is designed to be maintenance free. However, it is a good idea to clean the dome from time to time with a soft cloth, water, and dish soap.

Source: Winegard RoadTrip User Guide

Winegard Trav'ler Automatic Multi-Satellite TV Antenna Operation (SK-773, SKM-100, SWM-300)

This article provides basic operation instructions for a Winegard Trav'ler Automatic Multi-Satellite TV Antenna (SK-773, SKM-100, SWM-300).

Operation

The TRAV'LER antenna offers a simple one-button operation. Simply press "POWER," and the antenna will automatically begin searching for satellites. The instructions assume that the antenna is already in the stowed position.

1. Press and hold "POWER" for two seconds or until the TRAV'LER interface displays "POWER ON."
2. Once the unit has been powered on, release "POWER."
3. The interface screen will display the type of satellite dish on the top line.
4. The TRAV'LER antenna will enter the search mode as part of its normal operation and will display "Searching" on the bottom line.
5. The antenna will find its home position and begin to look for a satellite. Upon finding a satellite, the antenna will fine-tune or "peak" on the signal.
6. In automatic search mode, the TRAV'LER antenna will lock onto multiple different satellites. The antenna will display an asterisk for each satellite found.

TIP: If you want to turn off the power to the TRAV'LER antenna after the antenna has locked onto satellites, press "POWER" and "SELECT" at the same time. Before traveling, make sure to press "POWER" and wait for the antenna to start to power up; then press "POWER" again to initiate the stow sequence.

TRAV'LER SK-SWM3 SATELLITE ANTENNA

- DIRECTV Satellites: 99°, 101°, 103°
- Views 3 Satellites Simultaneously

TRAV'LER SK-1000 SATELLITE ANTENNA

- DISH Satellites: 110°, 119°, 129° (61.5° Manual Only)
- Views 3 Satellites Simultaneously
- Bell TV Satellites: 82°, 91°

TRAV'LER SK-7003 SATELLITE ANTENNA MOUNT

- Shaw Direct Satellites: 107°, 111°
- Views 3 Satellites Simultaneously

User Menu For Manual Operation

The interface includes a user menu for some advanced features. The options most commonly used are the ability to change the dish type, check software/hardware versions, change desired satellite configuration, or manually move the dish.

Ready To Travel?

The TRAV'LER antenna is not meant for use while traveling. To stow the unit when you are ready to travel, press "POWER" one time. The unit will stop what it is doing and return to the stowed position. The TRAV'LER interface will not turn off unless the TRAV'LER antenna is successfully stowed. Visually inspect that the antenna is in the stowed/ travel position before traveling. Do not move the vehicle until the TRAV'LER antenna is stowed.

WARNING

Improper use of the user menu could cause damage to the TRAV'LER antenna and/or vehicle. Do not enter the user menu for regular operation.

Emergency Manual Stow

If unable to stow the TRAV'LER antenna, it may be necessary to use emergency manual stow. Emergency manual stow is meant as a last resort and is not meant for common usage! To use emergency manual stow, unplug the interface box. Then, remove the black plastic bolt from the back of the mount. Insert a 5/16" socket extension into this auxiliary drive. Turn the auxiliary drive clockwise to lower the unit. Do not use a drill!

Emergency Power Off

The antenna comes with an emergency power off feature. To activate it, press and hold "POWER" and then press "SELECT" while still holding "POWER". The TRAV'LER antenna will stop and turn off. If the emergency power off feature is used, the antenna may not be in a safe position for travel. Do not move the vehicle until the unit is stowed.

Sources: Winegard Trav'ler Antenna Shaw Direct SK-7003,

Winegard Trav'ler Antenna DISH/Bell TV SK-1000, Winegard Trav'ler Antenna DIRECTV SK-SWM3



Blu-Ray Players

Blu-ray players offer full HD 1080p blu-ray disc playback. Many players also offer other features like streaming and a variety of applications.

Sony Blu-ray Disc Player Operation (BDP-S1700 and BDP-S3700)

This article provides basic operation instructions for a Sony Blu-ray Disc Player (BDP-S1700 and BDP-S3700).

IMPORTANT

These brief operation instructions are for quick reference only and should not take the place of the complete manual(s) provided by this product's manufacturer. Refer to the corresponding links and files in Newgle for more details about your product.

Front Panel Controls

1. Door Tray
2. Open/Close
3. On/Standby: Turns on the player, or sets to standby mode.
4. Power Indicator: Lights up when the player is turned on.
5. USB Jack: Connect a USB device to this jack.
6. Remote Sensor

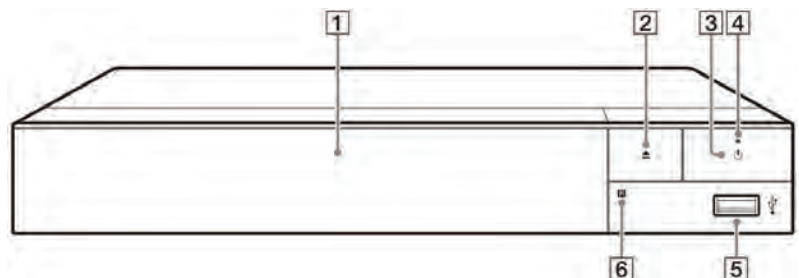

Rear Panel Controls

1. Ventilation Holes
2. Digital Out (Coaxial Jack)
3. HDMI Out Jack
4. LAN (100) Terminal
5. DC in 12 V (AC Adaptor Input) Jack

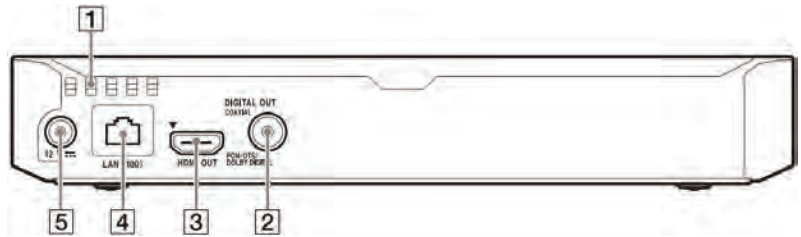

Remote Controls

The available functions of the remote are different depending on the disc or the situation. If any button on the player or remote is not pressed for more than 20 minutes, the player automatically returns to standby mode.

SECTION 1

- **OPEN/CLOSE:** Opens or closes the disc tray.
- **INPUT:** Switches between TV and other input sources.
- **TV (ON/STANDBY):** Turns on the TV, or sets to standby mode.
- **POWER (ON/STANDBY):** Turns on the player, or sets to standby mode

SECTION 2 (COLOR BUTTONS)

- Yellow, Blue, Red, Green: Shortcut keys for interactive functions.

SECTION 3

- **TOP MENU:** Opens or closes the BD's or DVD's Top Menu.
- **POP UP/MENU:** Opens or closes the BD-ROM's Pop-up Menu, or the DVD's menu.
- **OPTIONS:** Displays the available options on the screen.
- **RETURN:** Returns to the previous display.
- **ARROWS (◀, ▲, ▼, ▶):** Moves the highlight to select a displayed item.
- **▲/▼** as a shortcut key to launch track search window and input track number during music CD playback
- **▲/▼** as a shortcut key to rotate photo clockwise/counterclockwise by 90 degrees
- **◀/▶** as a shortcut key to perform search functions during DLNA video playback (BDP-S3700 only)
- **CENTER BUTTON (ENTER):** Enters the selected item.
- **HOME:** Enters the player's home screen.
- **FAVORITE:** Accesses the application registered as favorite.
- **NETFLIX:** Accesses the "NETFLIX" online service. For further NETFLIX online service details, visit <http://www.sony.com/bluraysupport/>

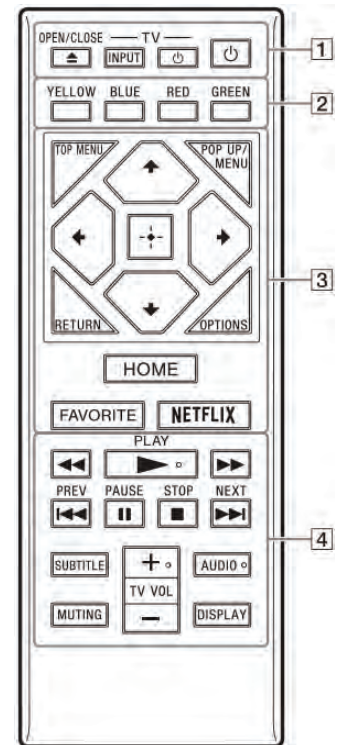

SECTION 4

- **FAST REVERSE/FAST FORWARD (◀◀/▶▶)**
- Fast reverse/fast forward the disc when you press the button during playback. The search speed changes each time you press the button during video playback.
- Plays in slow motion, when pressed for more than one second in pause mode.
- Plays one frame at a time, when you press for a short time in pause mode.
- **PLAY (▶):** Starts or re-starts playback. Use the tactile dot as a reference when operating the player.
- **PREV/NEXT (◀◀/▶▶):** Skips to the previous/next chapter, track, or file.
- **PAUSE (||):** Pauses or re-starts playback.

- **STOP (■)**: Stops playback and remembers the stop point (resume point). The resume point for a title/track is the last point you played or the last photo for a photo folder.
- **SUBTITLE**: Selects the subtitle language when multi-lingual subtitles are recorded on BD-ROMs/DVD VIDEOS.
- **TV VOL +/-** : Adjusts the TV volume. Use the tactile dot as a reference when operating the player.
- **AUDIO**: Selects the language track when multi-lingual tracks are recorded on BD-ROMs/DVD VIDEOS. Selects the sound track on CDs. Use the tactile dot as a reference when operating the player.
- **MUTING**: Turns off the sound temporarily.
- **DISPLAY**: Displays the playback information on the screen.

Operation

PLAYING A DISC

1. Switch the input selector on your TV so that the signal from the player appears on your TV screen.
2. Press OPEN/CLOSE, and place a disc on the disc tray.
3. Press OPEN/CLOSE to close the disc tray. Playback starts. If playback does not start automatically, select [Video], [Music], or [Photo] category in (Disc), and press ENTER.

PLAYING FROM A USB DEVICE

1. Connect the USB device to the USB jack on the player. Refer to the instruction manual supplied with the USB device before connecting.
2. Select [USB device] using ◀, ▲, ▼, ▶ and press ENTER.
3. Select [Video], [Music], or [Photo] category using ▲ / ▼, and press ENTER.

CHILD LOCK

You can lock the disc tray to avoid accidental opening of the tray. While the player is turned on, press the STOP, HOME, and then TOP MENU button on the remote to lock or unlock the tray.

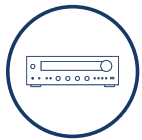

Audio Systems

Sony Bluetooth Audio System Operation (WX-920BT)

This article provides basic operation instructions for a Sony Blu-ray Disc Player (WX-920BT).

IMPORTANT

These brief operation instructions are for quick reference only and should not take the place of the complete manual(s) provided by this product's manufacturer. Refer to the corresponding links and files in Newgle for more details about your product.

Control Panel and Remote Operation

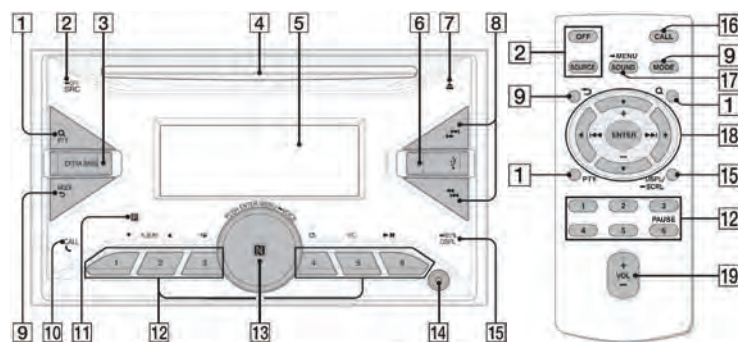

1. Browse: Enter the browse mode during playback (not available when a USB device in Android mode or iPod is connected).
2. Source (SRC/OFF): Turn on the power. Change the source. Press and hold for 1 second to turn the source off and display the clock. Press and hold for more than 2 seconds to turn off the power and the display. If the unit is turned off and the display disappears, operation by the remote commander is not available.
3. Extra Bass: reinforces bass sound in synchronization with the volume level. Press to change the EXTRA BASS setting: [1], [2], [OFF].
4. Disc Slot
5. Display Window
6. USB Port
7. Disc Eject
8. SEEK (**⏮** / **⏭** , **⏪** / **⏩**): Tune in radio stations automatically. Press and hold to tune manually.
9. MODE/BACK: Return to the previous display.
10. CALL: Enter the call menu. Receive/end a call. Press and hold more than 2 seconds to switch to Bluetooth signal.
11. Receptor for the remote commander
12. Number Buttons (1-6): Receive stored radio stations. Press and hold to store stations.
 - ALBUM (**▲** / **▼**): Skip an album for audio device. Press and hold to skip albums continuously. (Not available when a USB device in Android mode or iPod is connected.) Press **▲** to thumbs up, or **▼** to thumbs down in Pandora®.
 - REPEAT: (Not available when a USB device in Android mode is connected.)
 - Shuffle: (Not available when a USB device in Android mode is connected.)
 - MIC
 - Play/Pause (**⏮** | **⏭**)
13. Control Dial: Rotate to adjust the volume.
 - Push Enter: Enter the selected item. Press SRC, rotate then press to change the source (timeout in 2 seconds).
 - Menu: Open the setup menu.
 - Voice: Press and hold for more than 2 seconds to activate voice dial, voice recognition (Android smartphone only), or the Siri function (iPhone only).
 - N-Mark: Touch the control dial with Android smartphone to make Bluetooth connection.
14. AUX input jack
15. DSPL (Display) Press to change display items.
 - SCRL (Scroll): Press and hold to scroll a display item.

16. CALL: Enter the call menu; receive/end a call.
17. SOUND: Open the SOUND menu directly.
 - MENU: Press and hold to open the setup menu.
18. ARROWS (**◀** , **▲** , **▼** , **▶**): Select a setup item, etc.
 - ENTER: Enter the selected item. Press and hold for more than 2 seconds to establish or terminate the “Sony | Music Center” function.
 - PREV/NEXT (**⏮** / **⏭**)
 - ALBUM (+/-)
19. VOLUME (+/-)

Resetting The Unit

Before operating the unit for the first time, after replacing coach batteries, if the coach batteries were depleted, or changing if the connections, you must reset the unit. Press DSPL and CALL simultaneously for more than 2 seconds.

Note: Resetting the unit will erase the clock setting and some stored contents.

Setting The Clock

1. Press MENU, rotate the control dial to select [GENERAL], then press it.
2. Rotate the control dial to select [CLOCK ADJ], then press it. The hour indication flashes.
3. Rotate the control dial to set the hour and minute. To move the digital indication, press **⏮** / **⏭** (SEEK -/+).
4. After setting the minute, press MENU. The setup is complete and the clock starts. To display the clock Press DSPL.

Preparing A Bluetooth Device

You can enjoy music, or perform hands-free calling depending on the BLUETOOTH compatible device such as a smartphone, cellular phone and audio device (hereafter “BLUETOOTH device” if not otherwise specified). For details on connecting, refer to the Sony Bluetooth Audio System WX-920BT Operating Instructions.

Listening To The Radio

To listen to the radio, press SRC to select [TUNER].

TUNING

1. Press MODE to change the band (FM1, FM2, FM3, AM1 or AM2).
2. Perform tuning.
 - To tune manually, press and hold **⏮** / **⏭** (SEEK -/+) to locate the approximate frequency, then press **⏮** / **⏭** (SEEK -/+) repeatedly to fine adjust to the desired frequency.
 - To tune automatically, press **⏮** / **⏭** (SEEK -/+) Scanning stops when the unit receives a station.

STORING MANUALLY

While receiving the station that you want to store, press and hold a number button (1 to 6) until [MEMORY] appears.

RECEIVING THE STORED STATIONS

Select the band, then press a number button (1 to 6).

Playing A USB Device

1. Connect a USB device to the USB port. Playback starts. If a device is already connected, to start playback, press SRC to select [USB] ([the source] appears in the display when the it is recognized).
2. Adjust the volume on this unit. To stop playback, press and hold OFF for 1 second. To remove the device, stop playback, then remove the device.

CAUTION

iPhone ONLY: When you connect an iPhone via USB, phone call volume is controlled by the iPhone, not the unit. Do not inadvertently increase the volume on the unit during a call, as a sudden loud sound may result when the call ends.

Playing A Disc

1. Insert the disc (label side up). Playback starts automatically.

Playing A Bluetooth Device

You can play contents on a connected device that supports BLUETOOTH A2DP (Advanced Audio Distribution Profile).

1. Make BLUETOOTH connection with the audio device. To select the audio device, press MENU, then select [BLUETOOTH] → [AUDIO DEV].
2. Press SRC to select [BT AUDIO].
3. Operate the audio device to start playback.
4. Adjust the volume on this unit.

Source: Sony Bluetooth Audio System WX-920BT Operating Instructions



Remotes

On select coaches, all of the entertainment equipment can be operated with the use of a single universal remote.

Bose Sound System Operation (Solo 5)

This article provides basic operation instructions for a Bose Sound System Remote Control (Solo 5). On select coaches, all of the entertainment equipment can be operated with the use of a single universal remote.

Remote Control Operation

Use the remote to control sources connected to your system, adjust the system volume, change channels, use playback functions, enable cable/satellite box functions and navigate source menus.

SWITCHING BETWEEN SOURCES

You can switch from one source to another by pressing the appropriate source button on the remote.

1. Press the button for the source you want to control. The source button glows.
2. Press SOURCE. The source powers on.
3. Press TV INPUT and select the correct input on your TV.

FUNCTION BUTTONS

The red, green, yellow and blue buttons on the remote control correspond with the color-coded function buttons on your cable/satellite box or teletext functions.

- Cable/satellite box functions: refer to your cable/satellite box's owner's guide.
- Teletext functions: correspond with color-coded page numbers, headings or shortcuts on a teletext display.

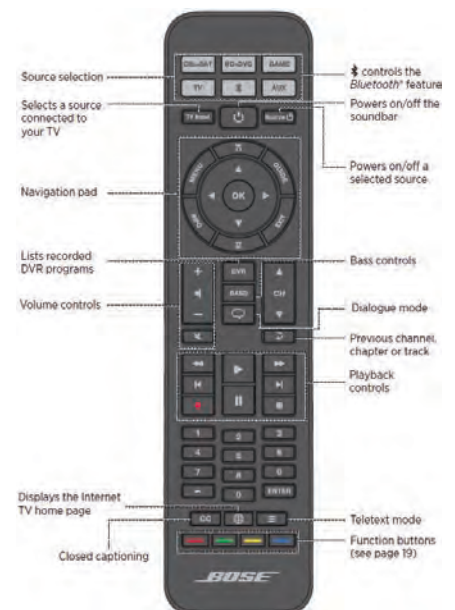

ADJUSTING THE VOLUME

On the remote control:

- Press + to increase the volume.
- Press - to decrease the volume.
- Press “SOUND OFF” icon to mute or unmute the audio.

ADJUSTING THE BASS LEVEL

1. Press the Bass button (BASS). The status indicator blinks white three times.
2. On the remote control:
 - Press + to increase the bass.
 - Press - to decrease the bass.
3. Press the Bass button (BASS). The status indicator blinks white three times and the soundbar saves your settings. For optimal sound quality for dialogue-only programs, such as news and talk shows, see “Dialogue mode.”

RESETTING THE BASS LEVEL

On the remote control, press and hold BASS for five seconds to reset the bass level to original factory settings.

The status indicator blinks white three times and remains solid white. The soundbar returns to original factory settings.

DIALOGUE MODE

Dialogue mode provides optimal sound quality for dialogue-only programs, such as news and talk shows, by decreasing the soundbar’s bass settings.

Press the dialogue button to toggle between dialogue mode and your default audio settings.

The status indicator glows amber when dialogue mode is enabled.

AUTO-WAKE

You can set the soundbar to power on whenever a sound signal is received. Note: The soundbar powers off after 60 minutes of inactivity.

Press and hold on the remote for five seconds until you hear a tone to toggle between auto-wake and default power settings.

The status indicator glows dim amber when the soundbar is off and auto-wake is enabled.

Source: Bose Solo 5 TV Sound System Owner’s Guide

Programming The Universal Remote Control

You can program the universal remote to control your source, such as a TV, DVD/Blu-ray Disc player, cable/satellite box, game system, or DVR, by entering the code for your source’s brand. There may be several codes for your source. You may need to perform this procedure multiple times to locate the correct code.

LOCATE THE CODE

1. Power on your source.
2. Locate the code for your source’s brand in the appropriate section of the Universal Remote Device Codes guide (refer to Newgle).

COMMON CODES USED BY NEWMAR

- Samsung: 00060
- Sony: 00000
- DirecTV: 01988
- Dish Network: 01989

ENTER THE CODE

1. On the remote control, press and hold the appropriate source button until all six source buttons glow, then release. For example, to program your TV, press and hold the “TV button” until all six source buttons glow, then release. The appropriate source button continues to glow.
2. On the number keypad, enter the code for your source’s brand and press the “VOL+” button.

TEST THE CODE

1. Test the source for basic functions by following the instructions for your source:
 - TV: Press the channel buttons. Press MENU. The settings menu appears. Press the left and right arrows to navigate.
 - Cable/Satellite Box: Press GUIDE. The programming guide appears. Press the left and right arrows to navigate.
 - DVD or Blu-ray Disc Player: Press GUIDE. The settings menu appears. Press the left and right arrows to navigate.
 - Game System: Press the left and right arrows to navigate.
2. Based on your source’s response to basic functions:
 - Remote responds accurately: Press EXIT to exit programming and save your settings.
 - Remote does not respond or does not respond accurately:
 - If your source button glows, press the VOL+ button to move to the next code. Repeat steps 1 and 2 in “Test the Code.” You may need to repeat this procedure 30 or more times. If all six buttons blink three times, you have cycled through all codes for your source.
 - If your source button is off, your remote exited programming mode. Repeat steps 1 and 2 in “Enter the Code” and steps 1 and 2 in “Test the Code.”
 - Note: Your source may not be compatible with universal remote controls or may not accept IR (infrared) signals. Refer to your source owner’s guide for more information.

CUSTOMIZING THE POWER BUTTON

You can customize the power button on your remote to power on/off your soundbar, TV, and cable/satellite box simultaneously.

1. Program your remote to control your TV and cable/satellite box.
2. Press CBL-SAT and TV simultaneously and hold for 10 seconds. Both buttons flash three times.

Bluetooth Operation

SOUNDBAR INDICATORS

The status and Bluetooth® indicators on the front of the soundbar provide information on soundbar activity.

STATUS INDICATOR

Status Indicator	System State
Off	Soundbar off (standby)
Green	Solid: Soundbar is on Blinking: Soundbar is muted
Amber	Dim: Standby, auto-wake is enabled Solid: Dialogue Mode Blinking: Dialogue mode, Soundbar is muted
Red	System error: Call Bose Customer Service

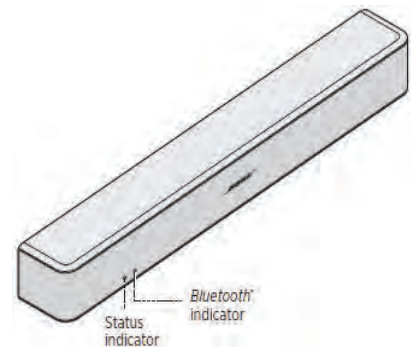

BLUETOOTH INDICATOR

Indicator Activity	System State
Blue	Blinking: Ready to pair
White	Blinking: Connecting Solid: Connected

PAIRING A BLUETOOTH DEVICE

Bluetooth® wireless technology enables you to stream music from Bluetooth smartphones, tablets, computers or other audio devices to the soundbar. Before you can stream music from a Bluetooth device, you must pair your device with the soundbar. Press the button for the source you want to control. The source button glows.

1. On the remote control, press the Bluetooth button until the Bluetooth indicator lights blue. Make sure the Bluetooth indicator blinks blue before you pair your device.
2. On your Bluetooth device, turn on the Bluetooth feature. Tip: The Bluetooth feature is usually found in Settings. A gear icon often represents Settings on the Home screen.
3. Select Bose Solo 5 system from your device list. Once paired, the Bose Solo 5 system appears connected in the device list.
4. On your Bluetooth device, play music to stream to your soundbar.

CONNECTING TO A PAIRED BLUETOOTH® DEVICE

You can stream audio from a Bluetooth device to the soundbar. Note: If there are multiple devices stored in the soundbar's pairing list, it may take a minute or two for the paired device to connect. The soundbar's Bluetooth indicator shows connection status.

1. On the remote control, press the Bluetooth icon. The soundbar connects to the last two devices that streamed to your soundbar.
2. Once connected, on the Bluetooth device, play music.

If you cannot stream audio from a paired device, the soundbar may have lost connection to your device. Check the soundbar's Bluetooth indicator. If the paired device is out of range of the soundbar, move your device within range.

SWITCHING BETWEEN CONNECTED DEVICES

The soundbar supports multi-point connectivity, which allows you to seamlessly switch playing music between connected devices. The last two devices that streamed to the soundbar remain connected. During playback, you can pause audio on the streaming device, and then play music from another connected device.

1. Pause music from the streaming device.
2. On another connected device, play music.
3. Repeat steps 1 and 2 to switch between connected devices.

Source: Bose Solo 5 TV Sound System Owner's Guide



Televisions

This article provides an overview of the televisions and related equipment installed in the coach. Your coach may be cable ready, and (depending on your floorplan) may have multiple flat screen televisions installed throughout the unit. The televisions are powered by 120 volt electricity, and the coach must be plugged into shore power, using the inverter (if equipped) or have the generator running in order for the televisions to function. The television operation is similar to most televisions used in the home.

The LED television(s) in your coach may be HD (High Definition) compatible, meaning they are capable of displaying the resolution and clarity of High Definition broadcasts and video sources.

Your coach may also be pre-wired for a satellite system and may be equipped with one interior television jack and an exterior television jack located on the passenger side of the coach. Choose the television source by selecting the input mode (air, cable, HDMI, etc.). The DVD player and satellite, if equipped, provides input to the front television(s) and exterior entertainment center. The bedroom DVD and satellite receiver, if equipped, provides input to the bedroom television.

⚠ IMPORTANT

The television in the front overhead cabinet will not operate while in transit. Federal regulations require this television to be inoperative while the vehicle is in use, so the power supply is switched off automatically when the ignition is turned on.

Exterior Entertainment Center with Samsung Television

This article provides a basic overview of the exterior entertainment center. For your convenience and pleasure, an Exterior Entertainment Center may be an option on selected floorplans. It may be located in either a basement compartment or in the sidewall of the passenger side of the coach and features a flat screen television

The television is mounted on a swivel bracket that allows you to swing the television out and away from the coach to provide better viewing angles. To release the television from its retainers, grasp the sides of the television firmly and pull it directly toward you. It will release and swing freely to the desired viewing position. To store the television for travel, swing it back into the opening, making sure that it is fully latched.

Depending on the year, model, and floorplan of your coach, this entertainment center may also feature a soundbar. While using the exterior television, the radio cannot be played through the soundbar. To select the sound source, use the sound bar remote.

⚠ IMPORTANT

It is important to make sure the TV is securely locked into position prior to closing the compartment door. Failure to do so can result in damage to the television case and screen.

⚠ IMPORTANT

The electronics used in the Exterior Entertainment Center are not designed for use in wet weather. The TV should be stored securely in the “travel” position and the basement door closed during rain or other adverse weather conditions. Caution should also be exercised when washing the exterior of your coach to make sure high pressure water does not enter the compartment. Spraying high pressure water at the seal between the doors can cause leaks, and potentially damage the electronics housed in this compartment.

Samsung Television Operation (M4500 / NU6900 / NU7100)

This article provides basic operation instructions for a Samsung Television (M4500 / NU6900 / NU7100).

Remote Control Operation

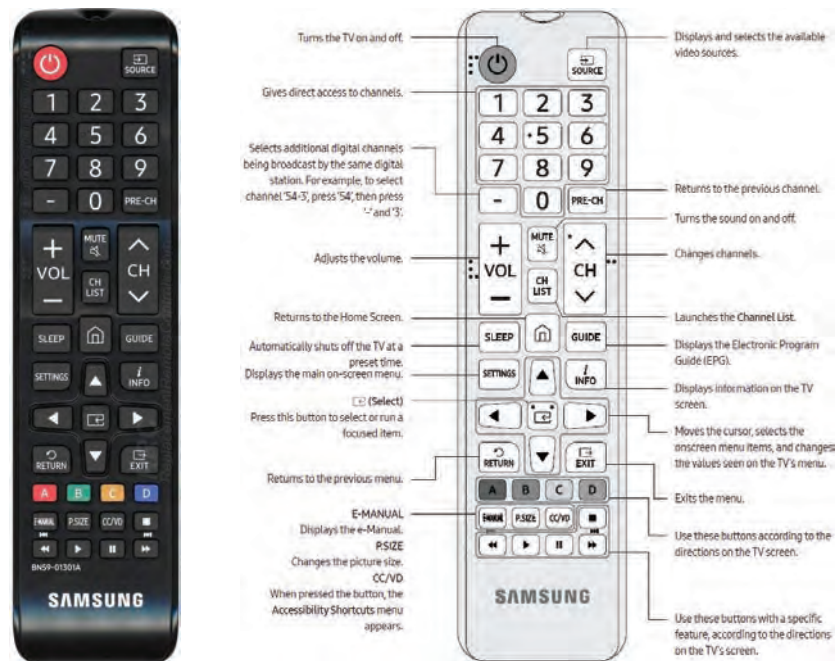

Accessing Samsung's e-Manual

You can view the embedded e-Manual containing information about your TV's key features. Press the menu button on the standard remote control to open the menu. Alternatively, press the button to open Smart Hub, press the left arrow until you reach settings, and then press Select.

Use the up and down arrows to move within this menu. Move to the Support option, select the e-Manual option, and then press Select to open it. The e-Manual contains two rows of buttons. Use the up and down arrows to move between rows and the left and right arrows to move within a row. Press Select to open the section you want to read.

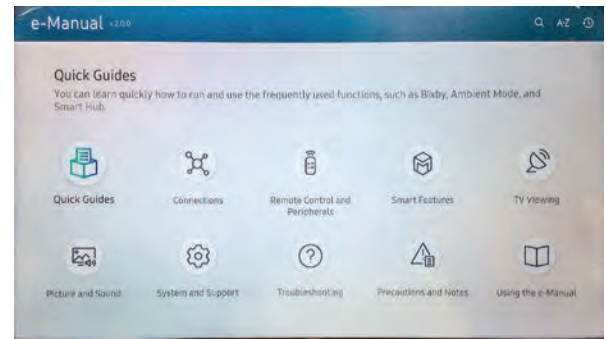

IMPORTANT

The Samsung e-Manual may contain features not applicable to your television.

Caring for the TV

- If a sticker was attached to the TV screen, some debris can remain after you remove the sticker. Please clean the debris off before watching TV.
- The exterior and screen of the TV can get scratched during cleaning. Be sure to wipe the exterior and screen carefully using a soft cloth to prevent scratches.
- Do not spray water or any liquid directly onto the TV. Any liquid that goes into the product may cause a failure, fire, or electric shock.
- To clean the screen, turn off the TV, then gently wipe away smudges and fingerprints on the panel with a micro-fiber cloth. Clean the body or panel of the TV with a micro-fiber cloth dampened with a small amount of water. After that, remove the moisture with a dry cloth. While cleaning, do not apply strong force to the surface of the panel because it can damage the panel. Never use flammable liquids (benzene, thinner, etc.) or a cleaning agent. For stubborn smudges, spray a small amount of screen cleaner on a micro-fiber cloth, and then use the cloth to wipe away the smudges.

Samsung Air TV Programming

This article provides the basic programming instructions for Samsung Air TV.

1. If there is no signal after turning on the television, push the Home button on the remote.
2. Use the left arrows until "Settings" appears on screen. Push "Select."

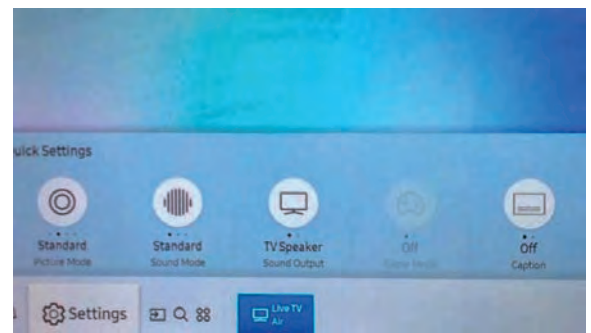

3. Scroll down to "Broadcasting," and push "Select."

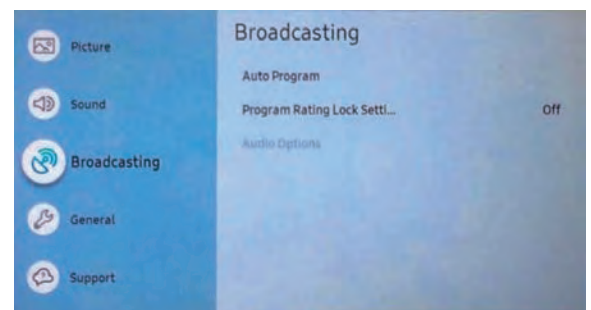
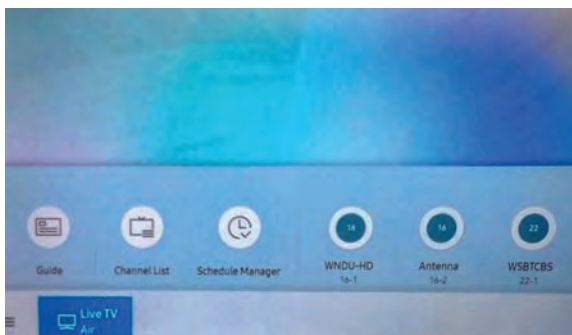

4. When “Auto Program” is highlighted, push “Select.”

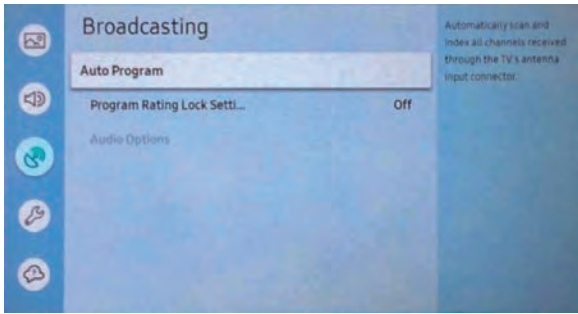

5. Highlight “Start,” and push “Select.” The TV will search for local channels and store them.

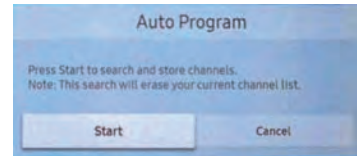

⚠ NOTICE
These steps will need to be completed each time the coach is moved to a new location.



EXTERIOR

Experience as much, or as little, of the outdoors as you want in comfort and style.

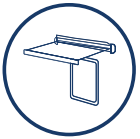

Awnings

Overview

Awnings are a standard feature on your coach. Newmar offers a variety of brands and types of awnings, depending on the year and model of your coach, as well as the available options that were selected at the time of your coach's manufacture. Select models may feature slideout toppers, entrance door, and/or window awnings.

The patio awning is the larger-sized awning on the coach and is the main awning. These awnings connect at or near the roof, providing shade, light, and rain protection on the passenger side of the coach.

The powered patio, window, and door awnings (if equipped) on your coach can be operated with ease. Use the appropriate switches to extend or retract the awnings as desired. Slideout toppers or covers operate as the slideouts are extended and retracted.

The switch is typically located in the overhead control panel. If they are not at this location, check above the passenger window, as it may be hidden by the window shade. Some coach awnings may also operate via a remote control or the SilverLeaf Virtual Keypad (if equipped).

IMPORTANT

Prior to extending any of your coach awnings, check for any obstructions that may prevent the awnings from deploying properly. Inspect the area around your unit where the awning will extend to ensure proper clearance.

CAUTION

Awnings should be retracted during accumulating rains. Pooling water on the awning can result in damage to the awning hardware and/or fabric.

NI-132

NOTICE

Damage to your awnings as a result of weather is not covered by warranty.

Dometic Power Patio Awning Operation (9100 Series)

This article provides basic operation instructions for a Dometic Power Patio Awning (9100 Series).

IMPORTANT

These brief operation instructions are for quick reference only and should not take the place of the complete manual(s) provided by this product's manufacturer. Refer to the corresponding links and files in Newgle for more details about your product.

Extending The Awning

1. Press and hold the (extend) awning switch until awning extends to its out position.



CAUTION

Maintain a horizontal distance of at least 16" between fully open awning and any permanent object.

NOTICE

Awning will stop when button is released no matter how far awning is extended / retracted.

⚠ WARNING

IMPACT OR CRUSH HAZARD: Do NOT allow awning to remain in over-extended position as this could trap heavy debris, or could cause water to pool or snow to accumulate on awning fabric. This weight will cause awning to become unstable, and bend or collapse. Failure to obey this warning could result in death or serious injury.

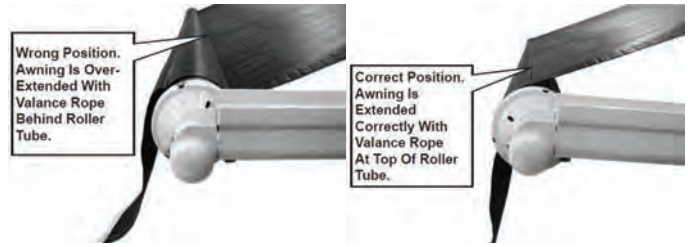

1. Verify valance is in correct position, and adjust if necessary. If the awning is over-extended, press the awning switch down to retract the awning until the valance is in the correct position.

Adjusting Awning Pitch

The FRTA (fabric roller tube assembly) will be lower than RV's awning rail when hardware is fully extended. This pitch (slope) will help accommodate water runoff. If a steeper pitch is desired, the FRTA must be lowered.

To lower FRTA:

1. With awning fully extended, loosen adjustable knob on adjustable pitch arm assembly (bottom arm).
2. Press in on spring loaded button on right side of adjustable pitch arm assembly to allow adjustment.

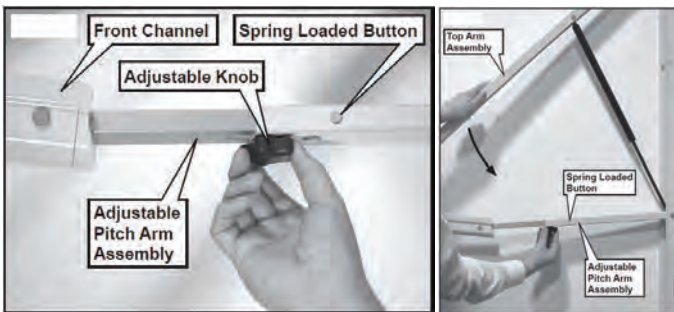

3. Pull top arm assembly down to lower FRTA to desired height.
4. While holding top arm assembly in place, tighten adjustable knob to set pitch (slope).
5. Repeat steps (1) through (4) for opposite side.

⚠ CAUTION

PINCH HAZARD: Keep CLEAR of openings around adjustable pitch arm assembly while adjusting awning pitch (slope). Adjustable pitch arm assembly (bottom arm) will telescope. Failure to obey this caution could result in injury.

⚠ NOTICE

Do NOT allow corner of entry door to contact awning fabric. Otherwise, premature wear or tearing of awning fabric could occur.

⚠ WARNING

IMPACT OR CRUSH HAZARD. ALWAYS lower one side of hardware into water shed position when adjusting awning [pitch / slope]. Otherwise, water could pool on awning fabric. Failure to obey this warning could result in death or serious injury.

⚠ IMPORTANT

Make sure the top arm assembly that's farthest from entry door is lowered more than the other.

Preparing The Awning To Shed Water

Lowering one arm assembly into water shed position (to create a slope from other arm assembly) will allow water run-off during light rain.

1. With awning fully extended, verify top arm assembly nearest entry door is fully extended, and that adjustable knob is tightened.

⚠ WARNING

IMPACT OR CRUSH HAZARD: Do NOT allow water to pool or snow to accumulate on awning fabric. The awning will become unstable, and could bend or collapse. Whenever heavy rain or snow is expected, place awning in stowed (closed) position. Failure to obey this warning could result in death or serious injury.

- Loosen adjustable knob on adjustable pitch arm assembly (bottom arm) that's farthest from entry door.
- Press in on spring loaded button on right side of adjustable pitch arm assembly to allow adjustment.
- Pull top arm assembly (farthest from entry door) down until awning slopes approximately 10°, or 9" minimum from other arm assembly.

IMPORTANT

This slope requirement is in addition to the slope from RV's awning rail.

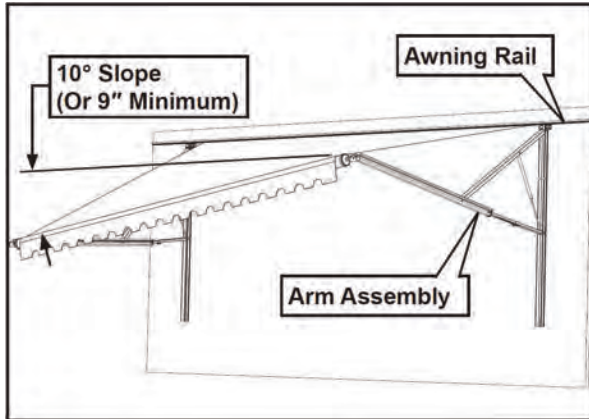

- While holding top arm assembly in place, tighten adjustable knob to set in place.

Retracting Awning Prior To Travel

- Remove any accessories from the awning, and make sure the awning path is clear of obstructions.
- Ensure the LED light strip switches are in the OFF position.
- Press and hold awning switch in the retract position until the awning is fully closed.

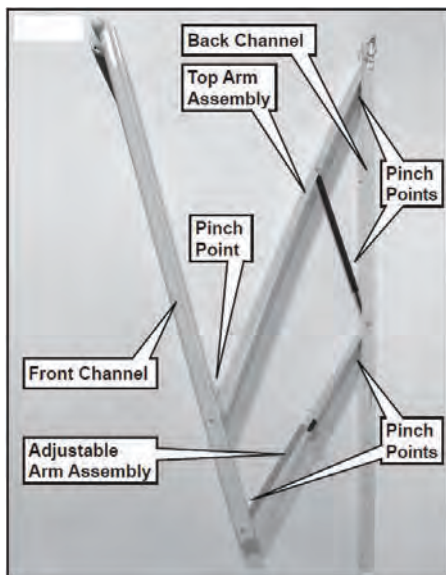

WARNING

IMPACT OR CRUSH HAZARD. NEVER disengage adjustable knob during windy conditions, or with water pooled or snow accumulated on awning fabric. This could cause the awning to move unpredictably, become unstable, and bend or collapse. Failure to obey this warning could result in death or serious injury.

NOTICE

Do **NOT** allow corner of entry door to contact awning fabric. Otherwise, premature wear or tearing of awning fabric could occur.

IMPORTANT

Lowering the arm assembly that's nearest entry door could allow door to contact fabric. If awning pitch was previously adjusted lower, raising arm nearest entry door will provide more fabric clearance.

CAUTION

PINCH HAZARD: Keep **CLEAR** of openings around adjustable pitch arm assembly while adjusting awning pitch (slope). Adjustable pitch arm assembly (bottom arm) will telescope. Failure to obey this caution could result in injury

WARNING

Keep **CLEAR** of arm assemblies while closing awning. Arm assemblies will [fold / close] against back channel. Failure to obey this warning could result in death or serious injury.

WARNING

IMPACT OR CRUSH HAZARD: Make sure ignition interlock is working correctly before traveling with RV. If awning responds to switch with ignition in ON position, accidental operation during transit could occur. The awning **MUST** be disabled, then serviced by a qualified service technician. Failure to obey this warning could result in death or serious injury.

Operating The Awning Via Handheld Remote Control

DOWN ARROW

Press and hold the down arrow to extend the awning.

UP ARROW

Press and hold the up arrow to retract the awning.

SQUARE ICON

Press the button with a square icon to stop the awning in the current position.

LIGHTS

- Press in the center between the double left and double right arrows to turn the awning lights on and off.
- Press the double left arrow to dim the LED light strip.
- Press the double right arrow to brighten the LED light strip.



⚠ IMPORTANT

If the coach is equipped with a separate awning light switch, the awning lights must be turned on via the Dometic remote control (press between the double left and double right arrows) before the light switch can be used to operate the awning lights.

Operating The Led Lights In The Awning Tube

Turn the awning light switch to the ON position to illuminate LED light strip in the awning tube.

Do NOT use the tube LED light strip while the awning is closed. Turn the awning light switch to the OFF position when the LED light strip is not in use.

Operating The Awning Manually

For information regarding manual operation of the awning during a power failure, refer to Dometic's 9100 Awning Operating Instructions in Newgle.

Source: Dometic 9100 Awning Operating Instructions

Compartments

Storage compartments are located on the exterior sides of your unit. These compartments provide additional space for your belongings while you are traveling. Select coach models feature optional manual slide trays and standard lighting, while others may feature compartments complete with power slide trays, dual side access, and automatic LED lighting throughout the storage area.



⚠ IMPORTANT

Before traveling, perform a pre-trip inspection that includes checking each baggage door to ensure each one is latched and locked securely.

⚠ CAUTION

Use caution when packing the storage areas. Do not pack items around water heaters, refrigerators, furnaces, hydronic heating units, or any other heat-producing appliances.



Doors, Handles, and Chimes

This article provides basic information about the doors, handles, and chimes installed in a Newmar coach. The front entrance door is equipped with a dead bolt lock for added security, and select coach models may have a power flush step well cover.

For your safety and convenience, all current models feature a grab handle at the entrance door to assist you in entering and exiting the coach. Select models may incorporate the keyless entry system, and many have a doorbell button integrated into the grab handle as well.

When the door is opened fully, the door has a “door check” feature that will automatically hold the door open. To close the door, simply pull to release the detent, then close and latch the door. Center entry doors may incorporate a gas strut to hold the door open.

Entry and Screen Door Overview

This article provides an operational overview of the entry and screen door.

NOTICE

This information is generic in nature and may not be specific to your exact coach model and/or year.

Deadbolt Operation

1. From the inside of the coach, operate the dead bolt by first making sure the door is closed securely in the second stage latch. Rotate the dead bolt lever clockwise.
2. From the outside of the coach, use the key and rotate it counter-clockwise to engage the dead bolt.
3. To lock the door without using the deadbolt, press and hold the number one key on the keyless entry touch pad (if equipped).
4. Flip the red lever before shutting the door, and use the key fob (if equipped).

NOTICE

Do not extend the deadbolt before closing the door, as damage may occur.

Entry Screen Door Operation

1. Store the entry screen door’s top screen for travel by pulling down in the center and unlatching the two hooks at the bottom.
2. Allow the screen to retract gently while continuing to hold the bottom of screen.
3. When not traveling, pull the screen down in the center, and latch the screen using the hooks at the bottom.

Manual Shade Operation

1. To lower the entry door manual shade, pull down near the center of the shade.
2. Release the shade slowly to keep the shade in the desired location.
3. To raise the entry door manual shade, quickly pull down the shade and gently release it, allowing it to retract. If necessary, hold the bottom of the shade to control the retraction speed.

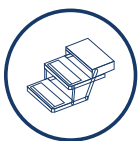

Entrance Steps

Your coach may be equipped with electric entrance door steps. Select coach models may be equipped with hydraulic steps. Both types of steps automatically extend when the entrance door is opened and retract when the entrance door is closed.

Electric Exterior Entrance Steps Overview

This article provides an operational overview of the electric exterior entrance steps installed on select coach models.

⚠ IMPORTANT

These brief operation instructions are for quick reference only and should not take the place of the complete manual(s) provided by this product’s manufacturer. Refer to the corresponding links and files in Newgle for more details about your product.



Operation

With the **Entrance Step switch** in the overhead cabinet flipped in the operational position, the entrance step will operate each time the entrance door is opened or closed.

If the door is closed when the **Entrance Step switch** is flipped opposite of the operational position, the step will extend one time. If the door is open when the Entrance Step switch is flipped opposite of the operational position, the step will stay extended.

The step will remain in the extended position unless the ignition signal is activated, which overrides the **Entrance Step switch**. In this case, the step will extend or retract when the door is opened or closed.

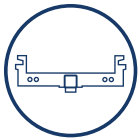

Hitches and Towing Components

Your motorhome is equipped with a hitch and tow plug, as it is designed for towing light loads. Your hitch may provide you with the capability of towing your car or trailer while traveling. A wiring harness or pigtail is needed to connect tail lights, brake lights, turn lights, etc. of the towed vehicle with that of the coach. Some coach models feature rear docking lights to assist with tow vehicle hookup at night.

Prior To Towing

Prior to towing, inspect all towing connections, including the hitch mounting bolts for unusual wear or corrosion. Check the mounting flanges for any deformation, as well as the hitch welds for any cracks, signs of movement, or fatigue in the hitch assembly. Safe and satisfactory performance of the towing system depends on the type of towing equipment connected to the hitch receiver. The assembled length of the drawbar/towing system used should be kept to a minimum. Do not exceed the rated capacities of the hitch or the components used to attach the towed vehicle or trailer.

⚠ IMPORTANT

Newmar is not responsible for damage or failure of the hitch receiver caused by the use of excessively long drawbars or other styles of drawbars that create leverage loads on the hitch receiver beyond its designed capabilities.

Towing Capacity

The total weight of the motorhome and any vehicle towed must not exceed the GCWR (Gross Combined Weight Rating). When planning to tow, approaching the GVWR (Gross Vehicle Weight Rating) may reduce the motorhome’s towing capacity. When weighing the motorhome, be sure to take passenger locations into consideration. The towed vehicles must have adequate active brakes. Contact your state Department of Transportation or your local Newmar dealer for your state requirements.



Ladders

This article provides safety information for using a ladder installed on a Newmar coach.

IMPORTANT

When going up or down the ladder, make sure the ladder is clear of debris, ice, water and any other slippery substance. Wear shoes that provide good traction. Slip-on shoes are not recommended when using the ladder.

IMPORTANT

The rear ladder maximum weight capacity may differ by manufacturer and dimensions of the ladder. Observe and do not exceed the weight rating for your ladder, which may be noted on the bottom of one of the ladder rungs.



Mirrors

Exterior Mirror Operation and Adjustment

This article provides basic operation and adjustment instructions for an exterior mirror.

Overview

Your coach may be equipped with convex remote-controlled two-part exterior rear view mirrors. The top portion of the mirror is flat, providing conventional reflected views down the sides of the RV, while the bottom portion is convex to provide an expanded view, helping to eliminate blind spots. These mirrors may also contain heating elements to defog, defrost, or de-ice the mirror glass during cold weather operation.

Operation

Some mirrors can be operated via remote control. These mirrors are adjusted by using the multi-directional switches located on the driver's door (optional on some models) or console. Make sure the seat is positioned for proper vehicle control, and then adjust the mirrors for maximum rear visibility prior to driving.



ADJUSTMENT CONTROL

The Mirror Control switch operates the electric portion of the mirror and adjusts the mirror up, down, back, and forth. To select which mirror to adjust, flip the selector to the left or right position. Move the selector to the center position to obtain the best view and make the directional arrows inactive. The adjustment control moves the top half of both mirrors. The bottom half of the mirror is convex and is adjusted manually.

HEAT

The red switch located near the mirror adjustment control operates the mirror heat (if equipped). The ignition switch must be on for the mirror heat switch to operate.

1. To turn the mirror heat on, turn the switch to the "ON" position. The light will illuminate on the switch when the mirror heat is operating.
2. To turn the mirror heat off, turn the switch to the "OFF" position. The light on the switch will turn off when the mirror heat is no longer operating.

IMPORTANT

Objects viewed in the convex mirrors are closer than they appear.



Paint, Roof, and Siding

This article provides a basic overview and maintenance of the roof and sidewalls.

Sidewalls

Newmar RV sidewalls are designed with structure to make them more rigid and dependable. By building aluminum frames with studs 16 inches on center, your sidewalls and roof will form a strong, lightweight, integrated structure so you can enjoy superior insulation. The sidewalls and end caps of your coach are constructed of smooth fiberglass, which is features an automotive style "Clear-Coat / Color Coat" painted finish.

SIDEWALLS MAINTENANCE

This article provides a basic overview and maintenance of the roof and sidewalls. Clean any unpainted fiberglass material with a mild cleanser and warm water. Use only soft cloths. Using stiff bristle brushes may cause scratches in the fiberglass surface.

⚠ IMPORTANT

Newmar is not responsible for weathering/oxidation of gel-coated surfaces.

EXTERIOR PAINT MAINTENANCE

For cleaning and waxing instructions and recommended products, refer to the Miscellaneous Care and Maintenance section in Newgle. Paint codes are typically posted on the back side of one of the upper kitchen cabinet doors.

Roof

This unit is manufactured with a 7mm decking material covered with fiberglass or rubber membrane. Proper care and routine maintenance of your roof is necessary for trouble-free performance. Inspection of roof seams and joints should be performed by an Authorized Newmar Service Center annually.

For units equipped with roof drains, it is important to make sure the roof drain catch basin strainers are cleaned and kept free of debris. There are four (4) of them, and they are located at the front and rear ends of the roof gutters, on both the left and right sides.

ROOF MAINTENANCE

Regular cleaning and maintenance is essential to insuring a long, trouble-free life. Before cleaning, it is important that you inspect the sealants and gaskets used to seal components to the roof structure to be certain there is no leakage during the cleaning process. Any cracks or voids in the sealants and seals MUST be repaired prior to spraying the roof with water. Extreme caution should be used when inspecting or cleaning the roof.

⚠ WARNING

It is recommended that access, cleaning, and maintenance be conducted by a qualified professional at your local dealership. Use caution if working on top of your vehicle. The wet roof surface is extremely slippery.

Rubber Roof Care and Maintenance

This article provides basic care and maintenance information for a rubber roof. Proper care and routine maintenance of your roof is necessary for trouble-free performance. A ladder may be installed on your coach to assist you in gaining access to the roof for the sole purpose of routine inspections and maintenance.

Proper care and maintenance of your recreational vehicle, including your rubber roof, is important for trouble-free performance. Normal maintenance is simple and easy, and does not require special materials. Keep the roof clean. Clean the roof at least four (4) times annually.

1. For normal cleaning, use RC100 Decor Synthetic Roof & General Purpose cleaner or a mild laundry detergent.

⚠ CAUTION

Do not use general purpose cleaners or conditioners containing petroleum solvents, harsh abrasives or citric-based cleaners. You may cause irreparable damage to your roof.

2. Rinse the complete roof with clean water to remove any loose dirt or debris.
3. Using a medium bristle brush, along with your selected cleaner mixed with water, scrub the entire roof. Rinse thoroughly with clean water to avoid residue build up on the roof or sidewalls of the vehicle.

4. For more difficult stains, you may use cleaning materials mentioned above in a more concentrated mixture. For stubborn stains, use of a cloth dampened with household bleach. Household bleach can be used (fully concentrated) and allowed to soak in stubborn stain areas, then scrubbed with a medium bristle brush or rag. Rinse thoroughly. Do not pour the bleach on the roof and allow it to run down the sides of the vehicle. Concentrated bleach may damage the graphics.

⚠ WARNING

Use caution when working on top of your vehicle. The wet roof membrane may be extremely slippery.

Exterior Paint Overview

We're passionate about paint. And we believe that the RV we create for you should be as beautiful as it is comfortable. Our coaches are more gorgeous than ever, with a sleek, stunning exterior showcased by all-new graphics and the exquisite Full-Paint Masterpiece™ Finish. Our goal is to create a perfect finish every time we paint a Newmar. This is how we do it:

- Between 12 and 16 gallons of paint are used on each model.
- Several types of primer are applied, followed by a base coat, color for graphics and a final, clear coat.
- We use materials of only the highest quality and integrity.
- Our technicians are among the most knowledgeable and highly experienced.
- The equipment and techniques we have created are among the most advanced.

We always ensure that each coat of paint lays flat and smooth to produce a stunning brilliance. That's how we can promise that your Newmar RV will offer you an exterior of the highest quality and durability.

For cleaning and waxing instructions and recommended products, refer to the Miscellaneous Care and Maintenance section in Newgle. Paint codes are typically posted on the back side of one of the upper kitchen cabinet doors.

DuraShield Flex™ Paint Protection Use and Care Guidelines

This article provides basic care and maintenance guidelines for the DuraShield paint protection.

Overview

DuraShield Flex™ Paint Protection Film is an extremely conformable, high-performance product. It provides superb conform-ability on highly-contoured vehicle surfaces and is the choice of industry-leading OEMs of high-end motorhomes. It also provides excellent protection to large, custom-painted surfaces exposed to damage from rock chips and road debris.

- Manufactured with a high-quality release liner and cap sheet to prevent “orange peel” effects that appear in some urethane films.
- Smooth, clear, high-gloss appearance will not distort the surface texture of the vehicle.
- Enhanced application conformability virtually eliminates the need for relief cuts and seams.
- A superior urethane surface also delivers greater scratch resistance while maintaining a high, OEM gloss level.
- Quick, self-healing properties allow the film to mend minor scratches with sun or heat exposure.
- Repositionable adhesive allows installers to apply and re-lift as needed without distorting the appearance of the adhesive.
- Provides excellent stretch capabilities, great for installation in colder climates.
- Carries a warranty against discoloring, cracking, peeling or adhesive delamination.

Care and Maintenance

The installation of DuraShield Flex™ by a certified installer will protect your vehicle from minor road abrasions, small paint chips, insects and minor scratches. DuraShield Flex™ is formulated in a way to look new for years to come with proper care.

For best results, these care guidelines can enhance the look of DuraShield Flex™ and maintain proper adhesion to the vehicle:

- Wait 48 hours after installation to wash vehicle to allow for proper adhesion.
- Wash the vehicle with care wash soap and water. Rinse thoroughly.
- Keep high pressure spray nozzles at least 2 feet from the edge of the film. The force of high pressure spray, if held too close, may cause edge lifting and peeling.
- Treat your PPF with DuraGlaze™ Polymer Finish on a regular basis (every 6 months) to repel staining, bug splats, bird droppings, dirt and road grime. Applying DuraGlaze™ will extend the life, gloss, and appearance of DuraShield™ films and make cleaning easier.
- Do not use a tinted wax or wax with abrasives. Do not use a machine buffer/polisher on the film.
- Do test any cleaning solution on a small section of film in an inconspicuous area before using.
- Dried wax along the edge of the film may be wiped away using rubbing alcohol and a cotton swab. Be sure to rinse area with clean water.
- Use a microfiber cloth when cleaning or waxing DuraShield Flex™. Coarse cloths or excessive rubbing can damage the appearance of the film.
- Do not use aromatic solvents such as acetone, M.E.K., toluene, paint thinner, lacquer thinner or gasoline on DuraShield Flex™.
- Do not apply an overcoat of clear paint or film.
- Tree sap, hard water deposits and other environmental elements can be harmful to paint protection films. Avoid parking in areas that may pose this problem. Apply DuraGlaze™ for greater protection from these conditions. Carries a warranty against discoloring, cracking, peeling or adhesive delamination.

Source: DuraShield Flex Care and Maintenance



Windows and Windshields

The windows installed in your coach are either single or double pane tinted safety glass. Most current models offer sliding glass windows. A power window may be installed on the driver's side on select models. Proper care and maintenance of your windows and windshield is critical to maintaining good visibility and safe operation of the coach.

How To Open and Close The Emergency Exit Windows

This article provides step-by-step instructions for opening and closing emergency exit windows and doors.



Hehr Egress Emergency Exit Window

Select Hehr windows have an opening window pane in the egress window for ventilation. This style of window can also be opened in the event of an emergency.

TO OPEN THE VENT:

1. Unclip and lower the arm.
2. Swing the arm 90 degrees, and push out on the arm until the red handle latches.

TO CLOSE THE VENT:

1. Unclip the red handle from the latch by lifting slightly while pushing outward.
2. Once the latch releases, pull the arm in until the window is closed.
3. Rotate the arm 90 degrees until it latches into the closed position.



IN THE EVENT OF AN EMERGENCY, OPEN THE WINDOW:

1. Remove the screen by pulling out on the red handle.
2. Push and release the lever from the locking hook.
3. Rotate the lever 90 degrees, and push it through the slot in the window frame.
4. Escape through the opening.

Hehr Double-Latched Emergency Exit Window

TO OPEN THE EMERGENCY EXIT DOUBLE LATCH STYLE WINDOW:

1. Unclip and lower the arm.
2. Swing the arm 90 degrees, and push out on the arm until the red handle latches.

TO CLOSE AND LATCH THE EMERGENCY EXIT DOUBLE LATCH STYLE WINDOW:

1. Pull the window shut while holding the window track with one hand.
2. With the other hand, rotate the latch up until it connects with the track on the window.
3. Press the front side down until it latches.
4. Repeat the steps for the second latch.



How to Operate a Vented Crank-Style Window

This article provides an operational overview of a vented crank-style window.

To open a vented crank-style window, rotate the window knob clockwise until the window reaches the fully-extended position. The operator arms near the bottom will be nearly straight when the window is fully extended.

To close a vented crank-style window, rotate the window knob counterclockwise until the window is closed and the knob can no longer be turned. The operator arms near the bottom should also be snug.



Skylights Overview

This article provides basic information about the skylight installed in the coach. For improved lighting and headroom, a skylight may also be installed in the bathroom over the shower. The opening provides additional light during daylight hours, and the skylight is tinted to provide privacy and reduce glare.

Maintenance

The skylight should be inspected with the roof and components, and the sealant should be maintained. Some sealants are not compatible with the skylight material. Newmar recommends using Surebond SB- 140 butyl sealant around the skylight.

How To Clean The Windows

This article provides information about windows used by Newmar, which are equipped with sliding screens that can be removed for cleaning.

Removing The Screen

Open the window and screen. Press upward on the screen frame top, pushing the frame deeper into its pocket. This will compress the springs and allow the screen frame bottom to rotate out of the bottom track. Be careful with the plastic screen springs, so that they can be re-used.

Cleaning The Glass

Apply straight mineral spirits to a clean, soft cloth and wipe the glass. Dry with a clean cloth. Next, clean the glass again, using a clean cloth with a 50-50 mix of water and a household window cleaner like Windex™ or GlassPlus™. If there is still a residue, remove it with rubbing alcohol and dry.

How To Prevent Window Condensation

This article provides a preventative overview of condensation on the inside of the windows and within the coach. Accumulation of condensation on surfaces within your unit occurs when warm, moist air contacts a cool surface. It is most evident on the inside of windows.

⚠ IMPORTANT

Since surface condensation within the coach cannot be controlled by the manufacturer, damage caused by condensation is not covered by your Newmar Limited Warranty.

Damage may occur to your unit if excessive condensation exists. This problem can be controlled by:

1. Slightly opening a window or roof vent to allow the moisture to escape from the unit.
2. A small dehumidifier is also very effective in removing moisture from the air.

Condensation levels are highest during times when a person is cooking or taking a shower in the unit, but these are not the only times condensation is present. Condensation can migrate through ceiling panels and saturate the fiberglass insulation in your ceiling cavity. This condition often causes the occupants to believe the recreational vehicle has a roof leak. Walls and ceiling panels may also become wet when the moisture accumulates on these surfaces.

⚠ IMPORTANT

Newmar Corporation does not recommend the use of any catalytic heaters.

Windshield Maintenance and Replacement

Proper care and maintenance of your windshield is critical to maintain good visibility and safe operation of the coach.

Care and Maintenance

Keeping your windshield clean will provide optimum visibility to view the road ahead. Should you encounter rock chips or cracks, have them fixed by an automotive glass professional immediately to avoid costly windshield replacement. If the crack spreads, replacement may be necessary.

⚠ CAUTION

Do not operate the windshield wipers with damaged blades, as they may cause damage to the glass. Damage to glass by rocks, damaged wipers, or other foreign objects are not warrantable repairs.

Check the windshield washer fluid level prior to each trip, and top off the fluid reservoir as needed.

Windshield Replacement

When replacing a windshield, Newmar highly recommends purchasing the new windshield through the Newmar Parts department to ensure proper windshield fit. Customers and dealers have experienced many size and installation issues when attempting to use aftermarket windshields. If your windshield needs replaced, make sure that your dealer or glass replacement company purchases the replacement windshield directly from Newmar.



Wiper Systems

Wiper System Care and Maintenance

Proper care and maintenance of your wiper blades is critical to maintain good visibility and safe operation of the coach. Clean the rubber element every time you fill your gas tank, and remove loose dirt and road grime from the windshield. When washing your coach, use a small amount of non-abrasive glass cleaner on a wet sponge to clean both the windshield and the rubber wiping elements. In colder climates, use an ice scraper to remove snow and ice. Using your wipers to de-ice your windshield can damage the blades, as well as the arm and wiper motor.

Streaking, chattering, and worn blades may be caused by dry rubber that has hardened and cracked. Streaking can also be caused by oil, tree sap, road tar, or other foreign substances on the blade rubber or windshield. Chattering sounds as the blade passes across the windshield are caused by the “deformity” or “curve” in the rubber that some wiper blades develop over time.

Worn, damaged, or split rubber around the wiping edge is generally caused by age and use, but may be due to the effects of the sun’s ultraviolet rays on the rubber. Damage may also be caused by ice scrapers, automatic car washes, or vandalism. Damage to glass by rocks, damaged wipers, or other foreign objects are not warrantable repairs.

WARNING

Replace your windshield wiper blades when they become worn or damaged. Worn or damaged wiper blades may cause damage to the windshield, as well as interfere with the driver’s ability, possibly resulting in a crash leading to injury or death.



HVAC

Let it rain. Let it shine. Inside your Newmar motorhome, you'll be as comfortable as you are in a traditional home — no matter what the weather has in store. Total Comfort Air Conditioning, consisting of two, fully ducted systems that distribute cool air and remove warm air, and various heating systems make climate control simple and effective.

The exclusive Newmar Total Comfort™ air conditioning system comes standard on every Newmar coach, giving you the ultimate in climate control right at your fingertips. Total Comfort. Total Control. All available to you with just the touch of a button. The Total Comfort™ Air Conditioning system is just another way every Newmar RV offers more for enthusiasts just like you.

Both incoming cool air and returning warm air are effectively managed through individual ducting systems to quickly create cold air and efficiently remove warm air. Multiple vents and returns are strategically placed throughout the RV to create a true central air effect.



Air Conditioning and Heat, Dash

Dash Air Conditioning and Heat Controls and Settings

The article provides a basic overview for the dash air conditioning and heat controls and settings. The dash air conditioning control panel enables the driver to control the temperature, volume, and direction of the air discharged from the heating/air conditioning system. Select coach models may have a driver and passenger control with a switch that allows the driver to override the passenger controls.

Controls and Settings

BLOWER SPEED

One of the best ways to control the temperature is by changing the speed of the blower. The blower knob (left of center) provides four speeds in any mode, except when the control is set to OFF.

TEMPERATURE CONTROL

The center knob controls the temperature of the discharged air. Turn the knob to the right (red area) for warmer air, and to the left (blue area) for cooler air.

MODE

To achieve the maximum comfort in your coach, the air must be directed where it is needed. The mode switch (right of center) gives the driver the ability to select where the air will flow. The air conditioning system is designed to operate in all modes except VENT, FLOOR, and OFF. This provides significant moisture, dust and pollen removal for enhanced passenger comfort.

IMPORTANT

If the mode knob is in any position other than OFF, the blower is always on a low speed unless a higher speed is selected.

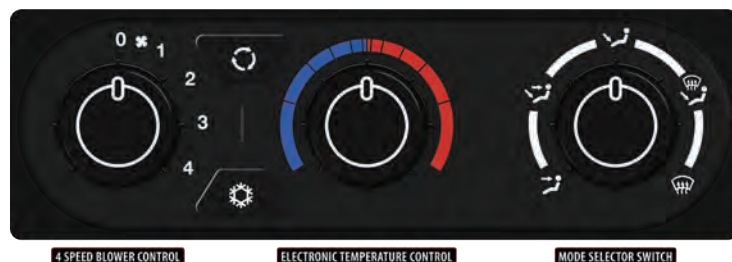
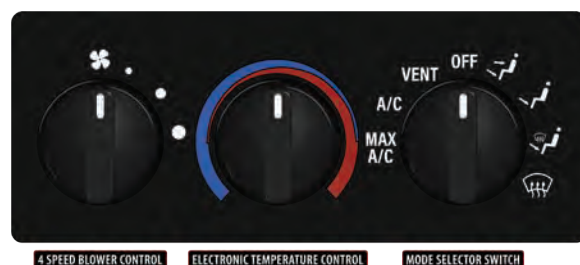

MAX A/C OR A/C RECYCLE BUTTON

Air is drawn from the passenger compartment and is discharged and recirculated through the dash louvers. This position is used to provide maximum cooling, and is generally used during extremely hot weather conditions for initial cool-down periods. Because this mode does not allow fresh “outside” air into the passenger compartment, it may cause fogging of the windows, and/or stale air, when used for prolonged periods of time. Switch to A/C mode periodically if these conditions occur.

A/C OR SNOWFLAKE BUTTON

Outside/fresh air is drawn into the system and discharged through the dash louvers. These louvers can be adjusted for maximum comfort.

VENT

Outside air is drawn into the system and discharged through the dash louvers. For enhanced passenger comfort, upper-level ventilation air is also discharged through the defrost outlets. When outside ambient temperatures are below approximately 40° F, the A/C compressor may cycle rapidly. Use Vent mode instead of A/C in these temperature conditions to cool the interior air temperature.

OFF

The blower motor does not operate in this mode. The fresh air inlet door closes, minimizing outside air infiltration into the vehicle.

BI-LEVEL

Outside air is drawn into the system and discharged through the dash louvers, floor, and defrost outlets. The A/C system operates in Bi-level mode.

FLOOR

Outside air is drawn into the system and discharged through the floor outlets. In some models, a small amount of air is directed to the windshield for defrost. The a/c system does not operate while in floor mode.

MIX

Outside air is drawn into the system and discharged through the floor and defrost outlets. The A/C system operates in Mix mode to provide windshield defogging.

DEFROST

Outside air is drawn into the system and discharged through the defrost outlets. The A/C system operates in Defrost mode to provide windshield defogging.

⚠ IMPORTANT

For operational safety in the event of the loss of vacuum, the HVAC system is designed to discharge air through the defrost vents to provide continuous windshield defogging.

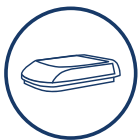

Air Conditioning and Heat, Roof

Roof Air Conditioning and Heat Overview

This article provides a brief overview of the roof air conditioning and heat pump, as well as filter maintenance. Keep your coach comfortable year around! Your coach’s air conditioners can be operated using the Comfort Control thermostat, KIB V-Bus LCD touchscreen, or the appropriate SilverLeaf screen.

Some roof top air conditioners have the ability to work as a heat pump when desired to produce heat instead of cooling. These models are effective at producing heat at ambient temperatures (above approximately 40 degrees). If the temperature drops below the threshold, most controls will revert to the furnace or hydronic heating system to produce the necessary heat.

Most air conditioning systems have a two minute built-in time delay, so there may be a slight delay in the operation of the air conditioner after the thermostat is set.

Filter Maintenance

1. Remove the vent cover from the return air duct or air conditioner.
2. Remove the filter.
3. Wash, rinse, and dry the filter. If the filter does not come clean, or is damaged, replace it with a new filter. Do not substitute other types of filters, as this may restrict air flow and cause other issues. Do not operate the air conditioners without filters.
4. Reinstall the filter on the cover, and place it back into the vent.
5. Repeat the process for each return air vent.



Fans and Ventilation

Vents operating on 12 volt power may be installed in your coach kitchen and bathroom. Depending on your vent setup, they may be controlled by a switch directly on the vent assembly or the switches located on the wall. Dash fans may also be installed on or in the front overhead cabinet and aid in windshield defrosting and air circulation in the cockpit area of the coach.

Dash Overhead Fan Overview

Gas Coaches

The O.H. Fans dash switch turns the overhead fan(s) on low or high, or turns them off, allowing the user to select the desired fan speed. The fan's purpose is to help circulate air around the windshield to prevent the windshield from fogging or icing up.



Fan-Tastic Vent Fan Overview

Fan-Tastic Vent will exchange the air in your vehicle in minutes. Cooking smoke and unpleasant aromas are whisked away in seconds. Fan-Tastic Vent can reduce the use of air conditioning allowing you to breathe natural, fresh ambient outside air. The core of the system is a powerful 12", 10-blade rotary fan that works with a slightly open window to create a balanced airflow. It is designed for maximum air exchange, minimum sound levels and power consumption. Fresh, clean, natural air is pulled in. Hot, stale, stuffy air is pushed out.

The vents may be controlled via a wall thermostat or the KIB switches or touchscreen panel and is equipped with a rain sensor on the roof hood. Anytime the vent is open and it senses rain, it will automatically close.

Once powered "ON" and the desired temperature is selected, the vent will run until the temperature is reached. When the temperature is reached, the vent will automatically shut off. The vent quickly clears the air in the coach.

IMPORTANT

Do not leave the fan in active mode while the unit is in storage or unattended for long periods of time. High winds, unusual conditions, or obstructions may prevent the vent from closing, resulting in leakage, which could cause serious damage to the coach interior.

Source: <http://www.fantasticvent.com/>

Fan-Tastic Vent Fan Operation via Wall Control

This article provides an operational overview of the Fan-Tastic Vent via Wall Control.

IMPORTANT

These brief operation instructions are for quick reference only and should not take the place of the complete manual(s) provided by this product's manufacturer. Refer to the corresponding links and files in Newgle for more details about your product.

Operation

1. Press the Power button at the top center to start the fan in the previously-used operating mode.
2. Turn off the fan, and close the lid.

MANUAL OPERATION MODE

Press the up or down arrows marked "Speed" to increase or decrease the speed of the fan. There are 13 speeds available, in 15 percent increments from ten percent to one hundred percent. The LED light(s) illuminate next to the selected fan speed percentage.

AUTO OPERATION MODE

Press the up and down arrows marked "Temp" to increase or decrease the temperature setting. There are 13 temperature settings available, in five degree increments from 60 to 90 degrees. The LED light(s) illuminate next to the selected temperature.



Vent Lid Operation

To open the vent lid without running the fan, press the Vent Lid button (up and down button below the speed arrows). Pressing the Vent Lid button will open the lid if it is closed and close the lid if it is open. If the fan is running and the user wants the dome open but the fan turned off, press the Power button at the top center, and then press the Vent Lid button to raise the vent.

Rain Sensor Operation

To disable the rain sensor, press and hold the Vent Lid button for three seconds. The Rain Sensor LED will illuminate when it is disabled. Press and hold the Vent Lid button for three seconds to re-activate the rain sensor and deactivate the LED.

Urea-formaldehyde Safety Guidelines

This article provides information about proper ventilation to prevent issues such as condensation and the release of urea-formaldehyde from coach products. Depending on your vent setup, they may be controlled by a switch directly on the vent assembly or the switches located on the wall. Dash fans may also be installed on or in the front overhead cabinet and aid in windshield defrosting and air circulation in the cockpit area of the coach.

Urea-formaldehyde is used in the production of particle board, hardwood plywood, and most paneling. Urea-formaldehyde resin may release formaldehyde vapors into the air, which may cause headaches, and in some people, eye, nose and throat irritation. Formaldehyde may intensify some allergies or upper respiratory problems like asthma.

Providing proper ventilation as needed by operating the power roof vents and opening windows should reduce the risk of such problems.

IMPORTANT NOTICE

Certain of our forest product suppliers have advised that urea-formaldehyde is used in the production of particle board, hardwood plywood or paneling which they supply us and which we utilize in our finish product. These suppliers have requested that we communicate this to our customers.

For your information, we are reproducing samples of statements which have been provided to us by our suppliers.

WARNING: THIS PRODUCT CONTAINS A UREA-FORMALDEHYDE RESIN AND MAY RELEASE FORMALDEHYDE VAPORS IN LOW CONCENTRATIONS. FORMALDEHYDE CAN BE IRRITATING TO THE EYES AND UPPER RESPIRATORY SYSTEM OF ESPECIALLY SUSCEPTIBLE PERSONS SUCH AS THOSE WITH ALLERGIES OR RESPIRATORY AILMENTS. PROPER VENTILATION SHOULD REDUCE THE RISK OF SUCH PROBLEMS. IF SYMPTOMS DEVELOP, CONSULT YOUR PHYSICIAN.

Adorn, Inc.

WARNING: IRRITANT: THIS PRODUCT CONTAINS A UREA-FORMALDEHYDE RESIN AND MAY RELEASE FORMALDEHYDE VAPORS IN LOW CONCENTRATIONS. FORMALDEHYDE VAPOR MAY, IN SOME PEOPLE, CAUSE HEADACHES, EYE, NOSE, AND THROAT IRRITATION AND AGGRAVATION OF ALLERGIES AND RESPIRATORY PROBLEMS, SUCH AS ASTHMA. PROPER VENTILATION SHOULD REDUCE THE RISK OF SUCH PROBLEMS. IF SYMPTOMS DEVELOP, CONSULT YOUR PHYSICIAN.

Woodbridge, Inc.

WARNING: THIS PRODUCT CONTAINS A UREA-FORMALDEHYDE RESIN AND MAY RELEASE FORMALDEHYDE VAPORS IN LOW CONCENTRATIONS. FORMALDEHYDE VAPOR MAY, IN SOME PEOPLE, CAUSE HEADACHES, EYE, NOSE, AND THROAT IRRITATION AND AGGRAVATION OF ALLERGIES AND RESPIRATORY PROBLEMS, SUCH AS ASTHMA. PROPER VENTILATION SHOULD REDUCE THE RISK OF SUCH PROBLEMS.

Robert Weed Plywood Corp

Ventilation is important in maintaining a comfortable environment and we direct your attention to the discussion of ventilation contained in your Owner's Manual.



Furnaces

How to Operate and Maintain the Furnace

This article provides basic operation and maintenance instructions for a forced-air furnace. The furnace installed in your coach is a forced-air furnace fueled by propane gas and is controlled by the air conditioner wall thermostat or the KIB touchscreen panel. This thermostat controls both the heating and cooling of the coach. The heat is supplied throughout the coach via the ducts in the floor.

For more information about the thermostat and KIB touchscreen, refer to Newgle.

⚠ WARNING

There are no owner serviceable parts on the furnace. Never attempt to modify this furnace. Fire, explosion, asphyxiation, or carbon monoxide poisoning may occur. If the furnace malfunctions, consult a trained service technician.

⚠ WARNING

Do not store anything directly in front or on either side of furnace.

⚠ AVERTISSEMENT

Ne rien poser contre l'avant ou les côtés du générateur d'air chaud.

Proceed with caution when storing items under the cabinets to prevent crushing or damaging the furnace ducting or blocking the cold air return.

The furnace will not operate properly if the air flow at the floor registers, or the air return to the furnace, is blocked by personal, storage items, or rugs.

Operating The Furnace

To operate, set the thermostat to the desired temperature setting and turn the thermostat ON. Allow 60 seconds for the furnace to begin operating. To shut down the furnace, turn the thermostat OFF. After the furnace has been turned off, the fan will run for approximately 60 seconds to cool down.

WARNING

For your safety, do not use gasoline or other flammable liquids near the furnace or any other appliance.

WARNING

OPEN VENT OR WINDOW ANYTIME VEHICLES, NOXIOUS FUMES OR OTHER HAZARDOUS ITEMS ARE IN THIS AREA.

MS-127

Smoke and fumes may be created as a result of the residual burn off of the manufacturing compounds that are sometimes present the first time the furnace is used.

This is normal; however, to minimize the smoke and fumes, the initial lighting of the furnace should be completed with the windows and doors open.

WATER COMPARTMENT HEAT VIA FURNACE

Coaches equipped with a forced-air furnace(s) have a designated heat duct for the water compartment in the basement to reduce the risk of freezing.

IMPORTANT

Heat output to the water compartment is only operational when the furnace is heating the interior of the coach.

Maintaining The Furnace

Check the gas system for leaks at least once a year. On the exterior of the coach you will find a furnace cover. This cover should be removed by authorized service technicians only.

Clean the complete furnace and air tube passageways periodically to remove dust, lint, etc. The furnace should be thoroughly cleaned before the start of each heating season. Any debris in the system may restrict air flow for combustion, bind the combustion air impeller, or prevent the blower motor from running properly.

Also, check the burner pilot orifices for debris. Lint accumulations may cause the blower to become unbalanced, vibrate, and restrict the ability of the blower to move air. If lint is blown into the heat exchanger, it may cause odors or create a fire hazard. Contact an authorized service technician for annual cleaning.

WARNING

Use caution when washing the exterior of your vehicle. Water should not be sprayed directly into the furnace vent. If water is forced beyond the rain baffles into the furnace vent, rusting of the furnace could occur. This could also cause improper combustion.



Thermostats

Keep your coach comfortable no matter where you are. Whether it's cold or hot outside, on the inside, you will always be "just right" using your coach's thermostat.

Dometic Comfort Control Center II Thermostat Overview

This article provides an operational overview of the Dometic CCC II thermostat.

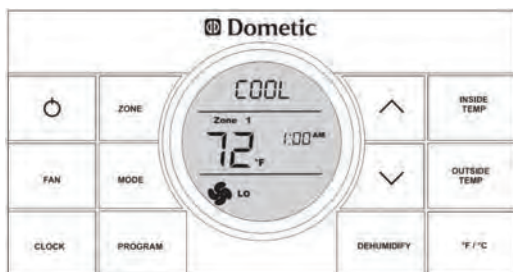

Power

Pressing the POWER button will turn the thermostat on or off.

Fan

Pressing the FAN button allows you to select the Auto (automatic fan selection) or manual setting of fan, as well as the fan speed (HIGH, MED, LOW).

Clock

Pressing the CLOCK button will cause the HOURS setting to flash, allowing you to adjust the HOUR value using the up and down arrows. Pressing the clock button a second time will cause the MINUTES setting to flash, allowing you to adjust the MINUTES value using the up and down arrows. Pressing the clock button a third time will set the time, and promptly exits out of the clock-setting mode.

Zone Button

Pressing the ZONE button allows you to select which zone to control.

▲ / ▼ Temperature Set

After selecting the zone and mode, this button allows you to determine the desired temperature by using the up and down arrows.

°F/°C (Temp Format)

Pressing the *F/*C button will allow you to choose between the Fahrenheit or Celsius settings.

Mode

Pressing the MODE button allows you to choose between various options, depending on the system installed in the coach. Choices may include the following:

- OFF = off
- COOL = setting for air conditioning
- AUTO = allows the thermostat to determine to use one of the heating options or cooling option to maintain a set temperature
- HP = heat pump setting to use A/C to heat instead of cool
- FURN = furnace setting to use the furnace for heating
- AQUA = coaches with Aqua Hot heating systems for heat instead of a furnace
- HS = heat strip (Newmar does not use this function, so it is likely that this option will not show up on the thermostat; however, if the dip switch for the heat strip is turned on, it will appear)
- FAN = fan only allows you to use the fan to move air without heating or cooling



INTERIOR

Amish craftsmanship and elegance in design meld the wood cabinetry and furniture seamlessly with the Newmar interior. Flooring, both tile and carpet, is installed with Newmar's own in-house process, ensuring the best in quality and longevity, as well as the finest fit. This category provides detailed information about your furniture, cabinetry, flooring, fabrics, window coverings, and all of the interior accessories that turn your coach into a home.



Beds and Mattresses

Several styles and sizes of beds and mattresses are available depending on your coach floorplan, such as pillow top and air mattresses. Your bed platform lifts to provide an additional convenient storage area. A strap may be provided to help raise the lid of bed base and is held open by pressurized struts to allow hands-free access.

Air Mattress Operation

This article provides basic operation instructions for an air mattress.

Air Mattress Operation with Built-In Pump

TO INFLATE THE AIR MATTRESS:

1. Unstrap and unfold the air mattress.
2. Open up the pump cord storage, and route the plug to a nearby 120 volt outlet.
3. Turn the arrow, and turn the switch on to inflate the air mattress.
4. When full, the sound of the pump will change. Turn the switch off.
5. Place the air mattress on the bed.

TO DEFLATE THE AIR MATTRESS:

1. Rotate the dial to deflate the air mattress.
2. Turn on the pump, allowing it to remove the air from the mattress.
3. When deflated, the sound of the pump will change. Turn the switch off.
4. Unplug and store the power cord.
5. Fold up the mattress.

Air Mattress Operation with Separate Pump

Some air mattresses are equipped with a U.L. approved electric inflation pump that plugs into a standard 11v household outlet. Position your sleep sofa so that accessing an electrical outlet is convenient.

TO INFLATE THE AIR MATTRESS:

1. Route the pump plug to a nearby 120 volt outlet.
2. Remove the valve cap on the air mattress by simply turning it counter clockwise.
3. After the cap is removed, insert the pump motor, and turn it clockwise until pump is engaged.
4. Allow the pump to inflate the mattress until the desired firmness is reached.
5. Remove the pump and replace the valve cap. A motor pitch change occurs when the mattress is full.
6. Replace the valve cap after inflation and seal valve by turning clockwise.

TO DEFLATE THE AIR MATTRESS:

1. Open the deflation valve by lifting the valve latch. Allow the mattress to deflate before folding.
2. Swing the valve to the closed position (do not lock).

WARNING

Air trapped in mattress by locking valve could cause damage. Do not lock valve while mattress is folded.



Cass Hudson Cockpit Drop Down Bunk Bed Operation

This article provides an operational overview of the Cass Hudson Drop Down Bunk Bed installed above the cockpit chairs in some coaches. The bed lift system stows the top bunk in the travel position at the ceiling.



Operation

TO STOW THE BED

1. Grasp the bed assembly firmly, and push up until both side latches are securely locked into place.

TO USE THE BED

1. Press the switch to release the latch.
2. Grasp the bed assembly firmly and pull down until it stops.
3. Hang the bunk ladder.



Safety Precautions

Coaches equipped with a drop down bunk bed may have labels adhered to a surrounding area to provide special instructions or weight capacities. Acknowledge and follow all warning labels to prevent any damage to equipment or personal injury. The following labels are examples only. Actual instructions and weight restrictions may vary.

⚠ WARNING

On coaches equipped with a flip-down bunk or bunk bed lifts, NEVER operate the bed(s) with person(s) or object(s) on the bed platform or travel with any object(s) other than bedding on the beds.

⚠ IMPORTANT

These brief operation instructions are for quick reference only and should not take the place of the complete manual(s) provided by this product's manufacturer. Refer to the corresponding links and files in Newgle for more details about your product.

⚠ CAUTION

Ensure that the areas above, below and adjacent to the bed are free from obstructions before operating the bed. Properly secure loads in the bed area to avoid damage to the bed mechanism from shifting or falling loads.

⚠ IMPORTANT

Raise the bed(s) to the FULL UP position when traveling to avoid damage to the bed as a result of bouncing.

⚠ WARNING

To help prevent serious or fatal injuries from entrapment or falls:

- Never allow a child under 6 years on upper bunk
- Use only a mattress that is _____ inches long and _____ inches wide on upper bunk
- Ensure thickness of mattress and foundation combined does not exceed _____ inches and that mattress surface is at least 5 inches below upper edge of guardrails

DO NOT REMOVE THIS LABEL

Max Weight

150 LBS

Bunk To Be

Used For

Sleeping Only

Flexsteel Lift-N-Lock RV Bunk Bed Operation

This article provides basic operation instructions for a Flexsteel Lift-N-Lock RV Bunk Bed. The space-saving design sits flush to the wall and turns unused vertical space into a bed with another sleeping area below, meaning no additional floor space is needed.

⚠ IMPORTANT

These brief operation instructions are for quick reference only and should not take the place of the complete manual(s) provided by this product's manufacturer. Refer to the corresponding links and files in Newgle for more details about your product.

Converting The Lift-N-Lock Sofa To A Bunk



1. Remove back cushions from the sofa.
2. Release the latch in the middle of the couch base by the floor.
3. Lift up on the sofa seat assembly and push up until it latches into place.
4. Pull up on the ladder assembly, lifting until it locks in place as the top bunk guardrail and ladder.
5. Lift and latch each side panel on the bottom bunk.

Converting The The Lift-N-Lock Bunk To A Sofa



1. Unlatch each side panel on the bottom bunk and lay it down on the mattress.
2. Pull the top bunk guardrail up and rotate out to drop it toward the bottom bunk.
3. Press inward to release the ladder and lay it down on the bottom mattress.
4. Push the sofa seat assembly down until it latches into place.
5. Place the cushions back on the sofa.

IMPORTANT

Adhere to warnings posted by Flexsteel regarding the weight and use of the convertible Lift-N-Lock Bunk Bed.

Sources: Flexsteel Lift-and-Lock Sofa Bunk Product Page; Flexsteel Lift-N-Lock RV Bunk Bed YouTube Video



Cabinetry and Woodwork

Cabinetry and Woodwork Care and Maintenance

Newmar's exquisitely crafted cabinetry newly gleams with chrome-finished hardware, the perfect complement to the array of appliances that make cooking and clean-up a breeze. Amish craftsmanship and elegance in design meld the wood cabinetry and furniture seamlessly with the Newmar interior. All Newmar cabinetry is custom built in our facility and designed with function and convenience in mind, as well as to provide as much storage as possible in your coach.

Construction

All joints on Newmar hardwood cabinets are glued, and then screwed together for extra durability. Hardwood raised panel cabinet doors are standard throughout the coach. Depending on your coach model, you may have hardwood cabinets or vinyl veneer finished cabinets. A variety of vinyl veneer and stain finishes are available for the cabinetry. A hand-sanded finish helps minimize seams so your hardwood cabinetry is as beautiful as it is durable.

Metal drawer guides provide a smooth opening and closing of the drawers in your coach. To open a drawer, lift up slightly and pull open. This feature helps prevent the drawers from opening during transit. Your unit may also include features such as adjustable pull out pantry boxes in the kitchen, soft-close drawers, or a molded silverware divider tray for added storage.

NOTICE
This vehicle is TSCA TITLE VI COMPLIANT and contains composite wood products that comply with the applicable California Code of Regulations Section 93120.2(a) Phase 2 (P2) formaldehyde emission standards specified on the above date of manufacture.

NOTICE
This vehicle is designed as a Recreational Vehicle. When used for an extended period of time, while furnace heating is required, sweating and condensation conditions may occur. The following precautions should be taken to minimize these conditions:
(1) Use range hood when cooking.
(2) Use the bathroom power vent when bathing or showering.
(3) Open windows slightly for ventilation whenever possible.
(4) Use dehumidifier to keep humidity as low as possible.

Humidity and Climate Change

Controlling the coach environment is the first priority of cabinet care and maintenance. Wood products shrink and grow according to the environment in which they are placed. These changes are in direct relationship to the relative humidity levels. As the humidity increases, the wood expands, and as the humidity decreases, the wood shrinks. This process does not happen instantaneously the longer the wood is exposed to low humidity, the more it will shrink as it dries out, and visa versa.

Coach owners who travel around the country may be more prone to this issue, as their coach is exposed to both extreme humidity and extreme dryness. It is necessary to acknowledge the fact that wood changes according its environment. Newmar recommends maintaining relative humidity levels between the range of 35-50 percent and temperature levels between the range of 40-90 degrees. The air conditioner or a dehumidifier will reduce the humidity level; however in dry climates, a humidifier may also aid in maintaining the appropriate humidity levels by raising the humidity level.

The following labels are examples of the notices that may be posted in the coach in regards to condensation prevention and formaldehyde exposure.

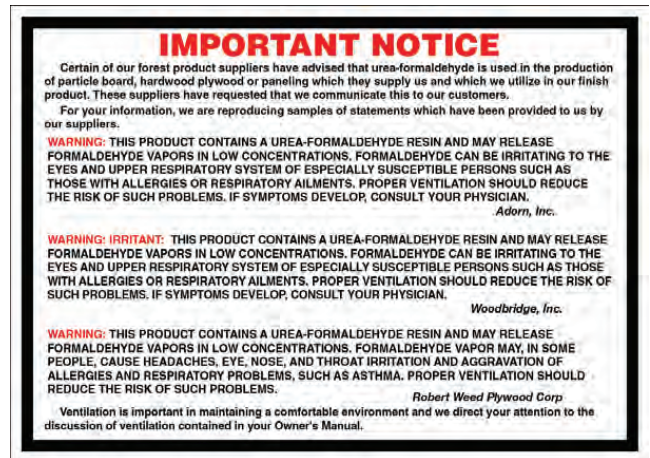

⚠ NOTICE

Hardwoods may change color or darken when exposed to sunlight. It is important that the window shades be down during long periods of storage. Changing shades of color, or discoloration, from exposure to sunlight is not a warrantable repair, as it is the nature of the hardwood products in your coach.

Care and Maintenance

The cabinetry should be wiped down with furniture polish to sustain the natural beauty and luster of the wood.

⚠ IMPORTANT

As with any wood product, do not saturate these cabinets with water or any other liquid. Be sure to wipe up spills as they occur to avoid staining.

Kitchen Cabinet Extension, Peninsulas, and Islands Overview

This article provides basic information about kitchen extensions, peninsulas, and islands.

Pull-Out Cabinet Extensions

The cabinet “extension” is incorporated directly into the kitchen cabinetry, and glides out on drawer guides to provide additional counter space when needed.

⚠ CAUTION

All pull-out cabinets must be secured prior to transit, as damage to the cabinetry and/or interior of the coach, or physical injury, may occur.

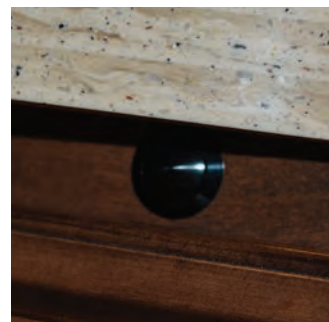

On 2017 and newer coaches, press the push button switch right above the pull-out island to release the island extension. On older coaches, unlock the extension by accessing the lever located in the top drawer.

Stationary Peninsulas

The stationary peninsula provides additional storage and countertop space. The kitchen slideout extends and retracts around the peninsula while it stays in place.



IMPORTANT

Make sure the countertop is clear of obstructions or debris in the path of the slideout before extending or retracting the slideout. Do not allow any objects to fall between the peninsula and the slideout, as they may cause damage.

Stationary Islands

The island provides additional storage and countertop space. The stationary island may house the central vacuum system, as well as crucial plumbing and electrical fixtures.



IMPORTANT

Make sure the areas around the island are clear of obstructions or debris and all cabinet doors are securely closed before retracting the slideouts.



Ceiling and Walls

The ceiling and walls in your coach are designed with more than function in mind, they are pleasing to the eye as well.

Ceiling and Walls Care and Maintenance

The ceiling in your coach may be covered with a padded vinyl ceiling headliner and should be cleaned periodically to maintain a new appearance. Use a non-abrasive cleaner with a soft cloth. Do not use solvents of any kind, as they may damage the surface.

The decorative wall coverings can easily be maintained and are not much different from wallpaper and should be cleaned with a solution of mild soap and water or a non-abrasive cleaner with a soft cloth.

CAUTION

For stubborn spots, test any cleaner on a area that is hidden, as some cleaners may fade or discolor the wall covering. Do not use solvents of any kind, as they may damage the surface.



Countertops and Backsplashes

Solid Surface Countertop and Backsplash Care and Maintenance

This article provides proper care and maintenance instructions for solid surface countertops and backsplashes. No special cleaning products are necessary; however, the countertops and backsplashes can be damaged if they are not cared for properly.

Cleaning

The solid surface composite countertops are non-porous, so most dirt and liquids sit on the surface and can easily be cleaned with a soap or mild detergent.

Wipe up spills as soon as they occur. Film can also build up on the countertop if water is left to dry, making it appear blotchy and uneven. Always wipe the countertop completely dry with a soft cloth after spills and cleaning.

Spray the surfaces with a hard-surface cleaner, and leave it for a few minutes before wiping clean with a damp cloth. Strong chemicals and solvents may damage the surface and should be wiped up immediately, then rinsed with water.

⚠ IMPORTANT

Avoid using window cleaners that may leave a waxy build-up that dulls the surface.

Avoiding Damage

HEAT

The solid surface countertops can be damaged with excessive heat or the use of harsh chemicals. Never put hot pans directly on the counter or in the sink. Avoid pouring hot liquids directly into a solid surface sink; run cold water while pouring hot liquid into the sink to avoid damage. If possible, allow the pan or pot to cool first.

Use caution when using heated appliances, such as crock-pots, electric frying pans, toaster ovens, etc. When possible, never use these appliances directly on the countertop.

⚠ IMPORTANT

Always use a heat pad or trivet to protect the surface from heat that may mar or damage the surface.

SCRATCHES

Try not to cut or chop food directly on the countertop, as you can score and scratch it. Slight abrasion marks may occur during normal daily use; cleaning regularly will ensure the durability and longevity of the countertops. Darker and heavily pigmented colors may show wear and tear more readily, and may require additional or more frequent maintenance.

Some deep scratches can be sanded out, and defects in solid surface countertops can be repaired, by trained professionals.

⚠ IMPORTANT

Always use a cutting board when cutting or chopping. Never cut or chop food directly on the countertop.

CHEMICAL SPILLS

Strong acids and cleaners may discolor the surfaces and should be wiped up immediately and cleaned with soapy water to prevent damage to the surface. Prolonged exposure may require professional repair or replacement.



Fabrics and Materials

Newmar uses only the most highly regarded names in residential décor to make their finest luxury coach a reality. High-quality fabrics are used throughout your coach, including the bedspread, shams, accent pillows, draperies, headboard, valances, and much more.

Fabrics and Materials Care and Maintenance

This article provides care and maintenance recommendations for the fabrics and materials installed in a Newmar coach.

⚠ IMPORTANT

The fading of upholstery, carpet and other interior fabrics can be caused by excessive sunlight. The drapes, blinds, or shades should be kept closed if the coach will be parked for an extended period of time to minimize fading. Normal deterioration due to wear and/or exposure to sunlight is not covered by the Newmar Limited Warranty.

The fabrics used in your coach may contain fire-retardant additives that may be damaged by use of improper cleaning products. Cleaning instructions for these items are DRY CLEAN ONLY. Water-based products are not recommended for cleaning the fabrics in your new unit. Most water-based household cleaning products are not formulated for use on these fabrics and may cause excessive shrinkage or fading. For best results, the fabrics in this unit should be cleaned by a professional carpet and upholstery cleaner.

Spills, spots, or stains should be treated as soon as possible to avoid permanent damage. If a spill occurs, blot the fluid with a dry towel. Do not rub the spill. Rubbing may cause the liquid to “set” in the fabric. When attempting to clean a spot or stain, always start from the outside and work inward to avoid spreading it further.

⚠ IMPORTANT

Some stains or soils are extremely difficult or impossible to be removed completely. These should receive immediate, professional attention. Spills, spots, stains or soils are the responsibility of the owner, and are not covered by the Newmar Limited Warranty.

⚠ WARNING

When cleaning the upholstery and fabric in the unit, do not use lacquer thinner, nail polish remover, laundry soaps, or bleach. Never use carbon tetrachloride or gasoline for cleaning purposes. These items may cause damage to the materials being cleaned, and most are highly flammable.

Ultrafabrics Cleaning Guidelines for Flexsteel and Villa Furniture

This article provides the care and maintenance guidelines for Ultrafabrics material.

One of the best ways to keep Ultrafabrics looking great is through proper maintenance and regular cleaning to prevent excessive dirt from accumulating. To help keep your quality fabrics looking their best, follow these guidelines to extend the life of the fabric:

- Wipe up spills as soon as they occur
- Clean with soap and water or alcohol based cleaners
- Sanitize using disinfectants such as (1:5) bleach/water solution
- For stubborn stains, wipe off with isopropyl alcohol as soon as possible
- Thoroughly rinse all solution residue with clean water
- Air dry

This information is not a guarantee. Please use all cleaning and disinfecting agents safely and as instructed. The use of other cleaning agents, disinfectants, conditioners or protectants is not recommended and can degrade fabric’s performance and may void Ultrafabrics warranty.

Ultraleather® | Pro note: A variety of clothing and accessories may contain dyes that could transfer to lighter colors, depending upon variations in temperature and humidity. Dye transfer is difficult to control, not always fully preventable, and may be irreversible. Fabric may not protect against intentional stains or permanent inks.

Source: Recommended Cleaning Instructions for Ultrafabrics

Dash Material Maintenance

This article provides suggested maintenance instructions for the dash material. In order to keep the dash in like-new condition, follow these guidelines:

Do–

- Dust and clean the dash with a soft, damp cloth, or chamois, wiping the surface gently.
- Use a mild detergent and lukewarm water.
- Dry the surface, after washing and rinsing, by blotting with a damp cloth or chamois.

Do Not–

- Use harsh chemicals that may damage the dash.
- Use cloths containing grit or abrasive particles or kitchen scouring compounds to clean or dust the dash.
- Subject the dash to hard, direct blows.
- Use boiling water or strong solvents to clean the dash, as they will soften the plastic.



Flooring

Flooring – both tile and carpet – is installed with Newmar’s own in-house process, ensuring the best in quality and longevity, as well as the finest fit. The flooring in every Newmar coach — from our high-quality, durable tile to the plush, luxurious carpeting— is placed with the highest level of care.

Carpet Care and Maintenance

This article provides care and maintenance recommendations for carpet. The installed carpeting is made of synthetic materials, mostly nylon fiber and is easy to maintain.

Vacuum regularly to remove dirt, dust, lint, and other abrasive grit. Water-based spills and spots should be soaked up and removed immediately with a damp cloth. Grease or oil based stains and spots should be spot cleaned with a commercial spot cleaner intended for this purpose.

When complete shampooing is desired or necessary, it is best to have it done be a professional carpet cleaner. Wait for the carpeting to dry thoroughly before walking on it.

⚠ IMPORTANT
Do not soak or water-log your carpeting.

⚠ IMPORTANT
In carpet areas that receive the most sunlight, close the curtains, blinds, or shades to prevent fading.

⚠ IMPORTANT
Act quickly to clean up when anything is spilled or dropped on the carpet.

Vinyl Flooring Care and Maintenance

This article provides care and maintenance recommendations for vinyl flooring, which is placed with the highest level of care.

For routine cleaning, sweep or vacuum regularly. Then, use a damp mop with warm water to clean a small area at a time. Rinse the mop frequently as to not redistribute the picked up dirt. If washing is needed, use a product designed for no-wax flooring.

⚠ IMPORTANT
Do not use solvent-based waxes or polishes, as damage to the flooring may result.

Tile Flooring Care and Maintenance

This article provides care and maintenance recommendations for tile flooring, which installed with Newmar’s own in-house process. The tile in every Newmar coach is placed with the highest level of care for the best fit, quality, and longevity.

As needed, sweep your floor to remove dirt and grit. Wipe up any spills promptly. Damp mop once a week (or more often for heavy traffic areas) using a tile cleaner. Use a neutral pH cleaner compatible with grout cleaning, professional carpet and upholstery cleaner.

⚠ IMPORTANT
Never use detergent, soap or other harsh cleaners, which can dull the surface or promote mildew growth. Cleaners should never contain acids, vinegar, chlorine, or ammonia, as these chemicals can damage and discolor both the grout and the stone or tile.



Furniture

Covered in coordinating fabrics and accented with pillows, a variety of furniture is available in your coach. Options may include recliners, sofa beds, dinettes, and booths. Your furniture is designed with function and design in mind. For more information about furniture, refer to Newgle.



Interior Doors and Hardware

The interior doors add to the beauty and privacy of your coach. Newmar installs a variety of functional doors from the basic hinged-swinging door, recessed hardwood pocket doors, and even pivoting doors on select floorplans. Each interior door is designed to fit and function for trouble-free operation.

IMPORTANT

Always secure all interior doors prior to travel to prevent damage to the doors and any surrounding objects.



Interior Furnishings

Interior furnishings such as clocks, artwork, and other decorations help make your coach feel like home. Other furnishings may be installed to provide the essentials and the amenities for your convenience while traveling.

Pictures, Clocks, or Wall Art

Most pictures and wall art installed at the factory have a hanger at the top and Velcro at or near the bottom. There may also be Velcro on the sides. To remove the picture or wall art, pull the Velcro loose at the bottom and sides, and then remove it from the hanging device. Some decorations without a frame may have exposed screws that may be difficult to find. For this type of decor, locate the screws, and remove them.



Interior Steps and Step Covers

On select coaches, the switch for the interior step cover is located either on the side of the passenger console or on the dash console near the center. This cover allows you to freely walk inside of the coach without having to be on the steps while in transit or when parked for longer periods of time. In addition, select coaches are equipped with step treads that can be lifted for additional storage.



Shades and Window Coverings

Power Windshield Shade Operation

This article provides basic operation instructions for a Power Windshield Shade.

NOTICE

This information is generic in nature and may not be specific to your exact coach model and/or year.

IMPORTANT

Do not manually pull down on the power shades, as damage may result.

Visor/Shade (Day Shade)

The Visor switch is located on the dash and adjusts the windshield screen up or down. When the ignition switch is turned on it limits the visor travel to approximately 1/2 way down and with the key off it travels all the way down to the dash. The screen will travel up until it reaches the stop setting.



Front Privacy Drape / Shade (Night Shade)

Press the UP or DOWN button for the appropriate shade. Switches may be labeled “Front Privacy Drape” or “Shade.” Switch-operated shades require the switch to be held until the shade either reaches its limit or the desired intermediate position (the shade can be stopped at any point by simply releasing the switch).

The switch labeled “Front Privacy Drape” or “Shade” is located in the overhead cabinet or on the dash and adjusts the windshield shade up or down.



1. With the ignition on, press and hold the switch in the down direction to extend the drape to the ignition stop set limit, which is approximately half-way. This is to allow the driver to see out the window.
2. With the ignition off, press and hold the switch in the down position to extend the drape until it reaches the “down” stop set limit.
3. With the ignition on or off, press and hold the switch in the up position to retract the drape until it reaches the “up” stop set limit.
4. Release the switch during travel to stop the drape extension or retraction between the “up” and “down” stop set limits.

Manual Day and Night Shade Operation

This article provides basic operation instructions for the manual day and night shades.



Day Shades

The first section visible when closing the shade is the “DAY” section. This material is translucent. Sunlight passes easily through the material into the unit while allowing a degree of privacy.

TO LOWER THE DAY SHADE:

- Grasp the shade near the center, and gently pull it down to the desired position.
- Release it slowly and gently to maintain the desired position.

TO RAISE THE DAY SHADE:

- Quickly pull down the shade and gently release it, allowing it to retract. If necessary, hold on to the bottom to control the speed of the retraction.

Night Shades

The second visible section is the “NIGHT” section. This material is a heavier, more opaque material. Very little to no light passes through it, so these shades are generally used in the evening or when more privacy is desired, though under certain light conditions, it can cast shadows and silhouettes.

TO LOWER THE NIGHT SHADE:

- Grasp the shade near the center, and gently pull it down to the desired position.
- Release it slowly and gently to maintain the desired position.

TO RAISE THE NIGHT SHADE:

- Quickly pull down the shade and gently release it, allowing it to retract. If necessary, hold on to the bottom to control the speed of the retraction.



PLUMBING

Plumbing Overview

⚠ CAUTION

Read and understand all operating instructions for the plumbing system prior to using your coach. Failure to connect and operate the system correctly may result in damage not covered by the Newmar Limited Warranty.

About The Fresh Water System

The Fresh Water System consists of the fresh water holding tank, water pump, valves, connection hoses, and fresh water plumbing lines. This system is responsible for providing potable water for drinking, cooking, bathing, and all other activities that require clean water.

The fresh water system begins with a hose or hose reel, which provides the connection to the fresh potable water. Then, via the fresh water valve, the water is diverted through the coach to be distributed through the cold water plumbing lines to the fresh water holding tank or to the cold water connections of each faucet and the water heater. From the water heater, the water is then dispersed through a series of water lines to each faucet on the hot water inlet and the hot water spigots (if equipped).

About The Waste Water System

There are two separate waste systems: the gray tank system and the black tank system, which includes sinks, lavatories, showers, tubs, and toilets. Each tank has its own control valve, and both tanks drain through the sewer drain hose. The waste water system catches and contains the used water and divert the waste water through the traps and drain lines to the grey or black holding tank(s). It is then stored until the tanks are emptied using a sanitary drain or dump station.

Water Compartment Overview

The water compartment in the coach typically contains the tanks and most of the controls for the plumbing system. It is usually located on the driver side of the coach immediately in front of the rear wheels, as it is isolated from other compartments, is heated and insulated, and sometimes occupies more than one compartment (gas coaches).

Ease of operation was the key element in the design of the water compartment and plumbing in your unit. The fresh water system in your coach is designed to operate at a maximum of 60 PSI. Water pressure levels above this level can damage the fresh water plumbing in your unit. If your water pressure ever surpasses 60 PSI, you must install a pressure regulator to reduce the incoming pressure, or fill the fresh water tank and use the internal water pump to supply water to your coach.

The water compartment contains parts of both the fresh and waste water systems, including:

- City Water Connection
- Whole House Filter
- Exterior Shower (if equipped)
- Waste Water Tank Drains
- Flushing Connections

⚠ IMPORTANT

Below are examples of water compartments. Components and setup will vary by coach model and year.



Bay Star Water Compartment

Water Compartment Heating via a Forced-Air Furnace

This article provides an overview of the water compartment heating via a forced-air furnace. Coaches equipped with a forced-air furnace have a designated heat duct for the water compartment in the basement to reduce the risk of freezing.



⚠ IMPORTANT

Heat output to the water compartment is only operational when the furnace is heating the interior of the coach.

Holding Tank Heat Pad Switches and Indicator Lights

This article provides a brief overview of the Holding Tank Heat Pad Switches and Indicator Lights. Coaches produced and equipped (after June 2015) with optional holding tank heating pads are GFCI-protected and incorporate an indicator light to the switch panel to signify that 120 volt electricity is being supplied to the heating pads.

If the indicator switch does not illuminate when you turn it on, check the GFCI outlet located in the basement compartment (the location will vary based on coach floorplan and tank placement).

The heat pad switches may be incorporated in the monitor panel in 2018 (and newer) coaches equipped with the KIB tank monitoring system.

If your coach is equipped with tank heat mats and the switch is activated, the tank heat icon will appear under the grey and black tanks. The tank level must be at least five percent for the control panel to send power to the tank heater and has a one minute delay before activation.

If the tank is equipped with a heating pad, there will be a tank indicator below the tank bar graph. When the tank heater is active, the indicator will turn orange. When inactive, the indicator will turn grey.



⚠ IMPORTANT

The TMS-100 is not monitoring any temperatures; this simply activates or deactivates the heat pads.

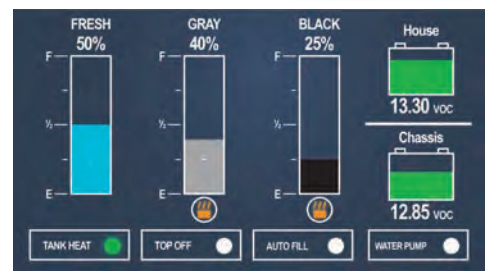

Fresh Water System

The Fresh Water System consists of the fresh water holding tank, water pump, valves, connection hoses, and fresh water plumbing lines. This system is responsible for providing potable water for drinking, cooking, bathing, and all other activities that require clean water. The capacity of your fresh water tank may vary, depending on the coach model and year.

Fresh Water Lines, Low Point Drains, and Plumbing Leaks

This article provides a basic overview of Fresh Water Lines, Low Point Drains, and Plumbing Leaks.

Fresh water lines are used to distribute potable water throughout the coach. The hot water lines are typically red in color or translucent with red lettering. The cold water lines are typically blue in color or translucent with blue or black lettering. Fresh water lines located beneath the slideout floor are typically heated to prevent freezing (i.e. refrigerator water supply). The water lines are routed in the heated water bay and inside the heated living area as much as possible.

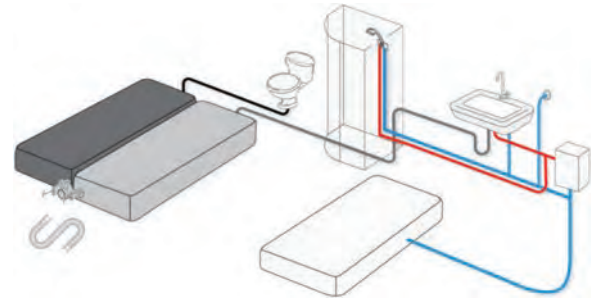

Fresh Water Lines To The Kitchen

The hot and cold plumbing lines connecting slideout-installed components, such as the kitchen sink and other optional equipment utilizing the coach water supply, are typically hard-plumbed within the slideout.

To ensure flexibility, a braided hose connects the rigid plumbing from within the slideout to the rest of the plumbing in the coach. This hose easily moves with the slideout as it extends and retracts. The plumbing lines are normally tied to the flexible drain pipe and extend and retract smoothly as the slideout travels.



Heated Fresh Water Lines

Heated fresh water lines are typically used on floorplans with bath fixtures or a refrigerator containing an ice maker or water dispenser located in a slideout. Heated water lines are used to connect the plumbing from the basement area to the refrigerator where the water lines are exposed under the slideout. The 12 volt power to the heated water line is usually fused in the cord compartment fuse panel in diesel coaches and on the firewall fuse panel on gas coaches.



Hot and Cold Low Point Drains

Low point drains are normally located in the water compartment and are marked “Low Point Drains.” Some valves are mounted in the water control panel and others are placed close to the water compartment and marked with a sticker nearby. Typically the coach has one hot water low point drain and one cold water low point drain, which are used to empty the water lines. Open the valves to relieve water pressure and drain the water lines. Close the valves for normal operation of the pressurized water system.

LOW POINT DRAIN CONFIGURATION EXAMPLES

On coaches equipped with tank rinse low point drain(s), turning the tank rinse drain valve to the “open” position will remove pressure and drain the tank rinse line. When finished using the tank rinse, it is recommended to turn off the water supply to the tank rinse connection. Open the valve, and drain off the pressure in the line before disconnecting the water hose.



Preventing and Repairing Plumbing Leaks

Vibration and flexing during traveling can cause pipes and fittings to work loose. Follow this checklist to prevent or repair any plumbing leaks:

- Check all of the plumbing connections for leaks on a yearly basis.
- If the water pump runs when all faucets are turned off, check for a leak.
- Be sure the drain valves are closed.
- Tighten any loose faucet connections with a wrench.
- Disconnect the leaking connections completely, and check for mineral deposits or foreign material on the sealing surfaces. Clean the surfaces thoroughly, and reinstall the fitting.
- Take the coach to an authorized service center for repairs if the system continues to leak.



Fresh Water Tank and Drain

This article provides a basic overview of the fresh water tank and drain. This tank is used to hold fresh potable water for use throughout the water system and is usually located on the floor of the water compartment; however, some coach floorplans may be equipped with a water tank located in another compartment. The fresh water tank is filled from the city water hook-up with a hose or hose reel.

⚠ WARNING

Potable water only. Sanitize, flush, and drain water tank before using. See owner's manual for instructions, care, and maintenance information. Failure to maintain tank can result in death or serious injury.

AD-04



The fresh water tank low point drain valve located in the service compartment near the water hook-up determines whether the city water is going through the water system or into the fresh water tank. The excess water will be vented from an overflow vent pipe onto the ground when the tank capacity has been reached. This pipe is installed in the fresh water tank to prevent tank rupture from overfilling.

Fresh water tank drains are located a few inches in front of or beside the fresh water tank and are connected to the fresh tank with a 1/2" or 1" water line.

Whenever possible, drain the fresh water tank before traveling or only carry what you will need to get to your destination. Water in the tank will reduce the carrying capacity of the coach. All of the water should be drained from the fresh water system when the coach is not in use for more than one week to prevent stagnant water and reduce organic growth. To drain the fresh water tank, open the valve located near the fresh water tank.

FRESH WATER TANK DRAIN CONFIGURATION EXAMPLES



Fresh Water Valves

The article provides a basic overview for the Fresh Water Valves in a coach. The rotating “Fresh Water Valve” located in the water compartment is used to pressurize the fresh water system in your coach, as well as to fill the fresh water tank when the coach is connected to city water.

The Fresh Water Valve position determines whether the water supply fills the tank or pressurizes the fresh water system in the coach. Simply rotate the “Fresh Water Valve” to the appropriate position to perform the desired function.

IMPORTANT

If you leave this valve in the manual tank fill position, you may experience low water pressure while operating the water pump.

FRESH WATER VALVE EXAMPLES



Auto Fill

For coaches equipped with an Auto Fill function, the coach must be connected to a pressurized water source and have the Fresh Water Valve in the “Auto Fill” position. In addition to turning the valve, the coach must also have the Auto Fill function enabled within the tank monitoring system. This function is used to automatically fill the fresh water tank and shut off the water supply based on the tank levels. The system will turn on the Auto Fill valve when necessary and turn it off when the tank reaches capacity.

Both the Precision Circuit Digi-level and the KIB TMSC-100 systems control the electric auto fill valve via the monitor panel in an overhead panel and are fused in the 12 volt house fuse panel. The KIB TMSC-100 system’s circuit board is typically located in the shore cord compartment, and the Digi-Level does not use a separate circuit board.

The SilverLeaf system allows the Auto Fill feature to be activated via the touchscreen or the SPX-300 panel located in the water compartment. It is controlled by the TM102 module and uses the fuse panel and relay board typically located in the shore cord compartment. For more information about the coach’s tank monitoring system, refer to the sub-category within the Electronics section.

City Water Connection

Before connecting to your coach, use a potable water source to purge any remaining air and stale water in the hose. Then, connect the hose from the potable water source to your coach or the hose from your coach to the city water supply (if equipped with a hose reel). Turn on the supply valve at the water source, and open each of the faucets to remove any air pockets in the coach plumbing lines. Once the water flows freely, close the faucet(s).



Water Pump

The water pump is used to pressurize the fresh water system when the unit is not connected to city water. The city water supply is under pressure, so the water pump is not necessary while you are connected to city water. Once the city water fill valve is not in the manual fill position, the water is supplied to the fresh water system components, including the hot water heater and faucets.

To disconnect from the city water supply, close the valve from the water supply. Release the pressure by rotating the fresh water valve to the tank fill position. Remove the hose from the city water supply, and store it in the water compartment. Once the pressure is relieved, rotate the fresh water valved to the appropriate operating position.

⚠ IMPORTANT

Use a water hose manufactured and labeled for potable water to ensure that the hose is drinking water-safe and will not alter the taste of the water.

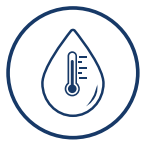

Water Heaters

Keep your water warm for cooking, bathing, and cleaning in your coach.

Atwood/Dometic Tank-Style Water Heaters with Direct Spark Ignition Operation

This article provides basic operation instructions for an Atwood/Dometic tank-style water heater with direct spark ignition.

⚠ IMPORTANT

These brief operation instructions are for quick reference only and should not take the place of the complete manual(s) provided by this product’s manufacturer. Refer to the corresponding links and files in Newgle for more details about your product.

⚠ IMPORTANT

Before operating the water heater, the tank must be filled with water.

⚠ WARNING

Do not store any combustible materials or liquids near or adjacent to the water heater.



To turn on and off the propane portion of the water tank, press the rocker switch on the Atwood water heater panel in the overhead compartment. The red reset button will illuminate if the water heater fails to ignite.

For coaches equipped with electric water heater elements, turn it on and off using the rocker switch on the opposite panel. The tank-style Atwood water heater is available in 4, 6, or 10 gallon sizes and use LP gas only or LP/Electric combination for the heat source.

Water Heater Operation On LP

1. Make sure the water heater is full of water and is not bypassed.
2. Turn on the gas valve on the LP tank.
3. Prior to activating the water heater, smell for any gas odors.
4. Turn on the switch to light the burner. The control board will attempt three times to ignite the LP at the burner. After three attempts, the red indicator light at the switch will illuminate.
5. If lockout occurs, turn the switch off, and wait several seconds before turning it back on. It will make three more attempts to light the burner.
6. On initial startup, it may take a few cycles to purge the LP lines.

Water Heater Operation With An Electric Element On 120 Volt Power

1. Check for the proper voltage supply (120 Volts).
2. Make sure the water heater is full of water and is not bypassed.
3. Turn on the switch to the electric element. The water heater will control the temperature.

Pressure Relief Valve

The temperature and pressure relief valve is located on the exterior of the water heater. It is designed to open if the temperature of the water within the heater reaches 210° F, or if the water pressure in the heater reaches 150 pounds.

Recreational vehicle water systems are closed systems, and during the water heating cycle, the pressure build-up in the water system may reach 150 pounds. When this pressure is reached, the pressure relief valve will open and water will drip from the valve. This dripping will continue until the pressure is reduced below 150 pounds, and the valve closes. This condition is normal and does not indicate a defective relief valve.



WARNING

Do not plug the relief valve under any circumstance.

Water Heater Bypass System

The water heater bypass valve(s) are located near the water heater. By closing the water heater supply valve and opening the bypass valve, you can divert water away from the water heater.

Using the bypass valve(s) while winterizing your coach will keep anti-freeze out of the water heater. Draining the water heater during winterizing is required. On most coaches, this consists of three valves: one at the inlet, one at the outlet of the water heater, and one in the middle (bypass) between the inlet and outlet lines. Some coaches may have a check valve on the outlet line allowing the use of fewer valves.

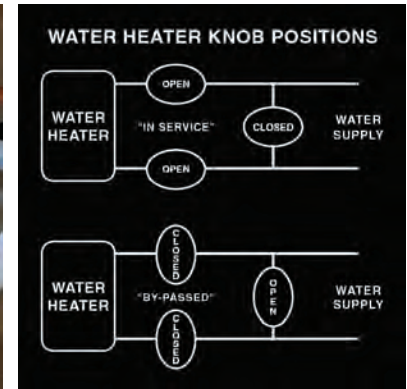

Water Pumps and Controllers

Water Pump Operation and Basic Troubleshooting

The water pump is self-priming and totally automatic, operating on demand whenever water is required. When not connected to city water, the coach's water pump is used to pump and pressurize water from the fresh tank for distribution through the hot and cold water lines.

When the water pump switch is turned on, the water pump builds pressure in the system and will shut off as soon as the system is correctly pressurized. When a faucet is opened, the pump will turn on and operate as necessary to maintain the preset pressure in the system. Water pump operation is not necessary while the coach is connected to city water, since the potable water is already pressurized.

When using water at a low flow rate (GPM), the pump may pressurize the system and short cycle, meaning the pump shuts on and off quickly. In many cases, the pump will stop short cycling if the flow rate of the water is increased.

Operation

1. Fill or partially fill the fresh water supply tank.
2. Open the kitchen and bathroom faucets.
3. Turn the water pump switch on, and allow the water to fill the water line and the hot water heater. The switch to this pump may be located in the exterior water compartment, in the kitchen, or in the bathroom.
4. Close each faucet after it delivers a steady stream of water (close the cold water first). Leave the hot water faucets on until they also deliver a steady stream of water. This will ensure that the water heater is filled with water.
5. The water pump should stop running once all faucets are closed.
6. The pump is now ready for automatic operation. The pump will run when a faucet is opened and stop when a faucet is closed and the correct pressure has been reached.

⚠ CAUTION

Never allow the pump to run for long periods of time without water in the supply tank, as pump damage or blown fuses may result.

Care and Maintenance

All of the water should be drained from the fresh water system when the unit is not in use for more than one week.

Troubleshooting

If water doesn't flow when a faucet is turned on while using the demand system, use the following troubleshooting tips.

If the pump is running, but there is no water:

- Fill the tank.
- Clear the water line to the pump or the pump inlet filter.
- Rotate the city water / tank fill valve to the correct position.

If the pump isn't running:

- Check the pump switch.
- Check the 12 Volt fuses.
- Check the electrical connections.
- Check the battery.

Water Pump Operation via C-Storm Controller with Momentary Contact Switches

This article provides a basic overview of the water pump operation via a C-Storm Controller with Momentary Contact Switches. The water pump may be operated from one or multiple locations, depending on the coach model, year, and floorplan.

The C-Storm water pump controller uses momentary contact switches with an LED indicator that is wired to a C-Storm latching control module that turns the pump on and off. The pump constantly has 12 volts being supplied to the pump motor. The ground side of the pump motor is turned on and off by the C-Storm water pump controller. This system uses a fuse located in the Newmar house fuse panel in the bathroom or front overhead panel on most coaches. The switches may be located in the exterior water compartment or in the coach (may be used with C-Storm or KIB System).



Faucets and Fixtures

Your installed bathroom and kitchen faucets and fixtures are available in many styles, finishes, and configurations, often complementing the other fixtures in your coach.

With proper maintenance, the faucets in the coach should provide years of trouble-free usage. The faucets and fixtures can be cleaned by wiping with a soft, damp cloth. Washing with warm water will remove dry water spots. Turn off the water and drain the pressure before attempting repair or replacement of the faucet.

⚠ IMPORTANT

Avoid using "S.O.S." type cleaning pads or other abrasive cleaners because they may scratch the surface. Do not use cleaners that contain harsh or abrasive chemicals. Alcohol or similar solvents should never be used.



Filters

Water Filter Care and Maintenance

This article provides basic care and maintenance recommendations for water filters. Your coach may be equipped with a fresh water filtration system. This system uses extruded carbon filter cartridges to remove sediment and certain impurities from the incoming water supply. The filter assembly is located in the basement water compartment. Select coach models may also have additional filters installed for drinking water.

When To Replace Your Filters

Most water filter manufacturers recommend that you replace your water filters every six months. These guidelines are based more on average household size and average consumption rates rather than your specific coach. The frequency of filter changes depends upon your water usage and the quality of water you are using. As you travel and hook up to different water sources some may contain more sediment, metals, sulfur and other impurities which affect the filter life, the taste and smell of your water. Other factors are how often it is used and stored and how long water is able to sit in the holding tank and become warm and stagnate.

Change the filter at least every six months and at any time you notice decreased water flow or notice unpleasant taste, odor, or algae after flushing and sanitizing the water system. Water filters and fresh water system maintenance are the customer's responsibility in order to ensure safe potable water.

Flow-Pur Whole House Water Filters

This article provides basic instructions for replacing a Flow-Pur Whole House Water Filter. Replacement filter cartridges are available through the Newmar parts department.

1. To replace the filter cartridge, turn off the water supply to the coach at the city water connection, or turn off the water pump if using potable water.
2. Drain the water pressure off the system by opening a faucet or low point drain, and press the red button on top of the filter housing.
3. Unscrew the filter canister by rotating to loosen and remove it (the top housing has male right hand threads, and the canister portion has female threads).
4. Insert the new filter cartridge, positioning it so the opening in the bottom of the filter is placed on the molded ring at the bottom of the canister.

CAUTION

When replacing the filter, make sure the rubber O-Ring seal is properly positioned in its groove in the cartridge housing. An improperly positioned or missing seal will cause leakage around the perimeter of the filter housing.

5. Reattach the canister to the filter housing by rotating the canister until it tight. Do not over tighten the canister when attaching it back to the housing.

IMPORTANT

Do not allow water to freeze in the water filter canister. Freezing will crack and permanently damage the filter housing and associated plumbing. Always remove the filter cartridge prior to winterization.





Power Washers, Sprayers, and Exterior Showers

Exterior Shower Overview

An exterior shower located in the water compartment on the driver side may be an optional feature on your coach and can be used to rinse off sand or grass, muddy shoes, or bathe a pet outside of the coach. The exterior shower may also be used to wash your hands or rinse off the sewer hose after dumping the waste water tanks.

The faucet operates just as it would in the kitchen or bathroom. When finished using the exterior shower, shut off both the hot and cold valves. Do not simply shut off the valve on the shower head itself, as it may cause hot and cold water to mix at the exterior shower and could allow drastic changes in water temperature throughout the coach.



Waste Water System

There are two separate waste systems: the gray tank system and the black tank system. Each tank has its own control valve, and both tanks drain through the sewer drain hose.



Sinks, Tubs, and Showers

This article provides an overview and care and maintenance recommendations for sinks, tubs, and showers. The sink and shower are the beginning of the waste water system. The basic purpose is to contain the used water so it can be drained via the attached waste water drain line to the holding tank.

Care and Maintenance

The maintenance requirements for sinks and the shower are on an as-needed basis. Occasionally, the attached drain and trap may need to be cleaned of soap scum and hair to maintain efficient drainage. The basins and shower walls can be cleaned to maintain the original luster. Clean the entire surface, including the exterior, of the lavatory and kitchen sinks and shower with mild soap and warm water. Wipe the entire surface completely dry with a clean, soft cloth.

⚠ IMPORTANT

Avoid using “S.O.S.” type cleaning pads or other abrasive cleaners because they may scratch the surface. Do not use cleaners that contain harsh or abrasive chemicals. Alcohol or similar solvents should never be used.

Follow these tips to maintain the shower(s) in the coach:

1. Make sure the shower doors are closed and latched or locked prior to travel.
2. Check for leaks in the shower seals. Reseal them as needed.
3. Using a mild detergent and a soft cloth, wipe down the shower walls and glass enclosures after each use to avoid soap scum and hard water deposits.
4. When winterizing the coach, clean up any remaining antifreeze in the shower, as it may cause staining.

Waste Water Drain Lines

The drain lines are plumbed from the sinks, showers, and toilets are sloped to drain waste water to the grey or black tank. However, if the coach is equipped with a lift pump, refer to the “Lift Pump” article. If the coach is equipped with macerator toilet(s), refer to the toilet article(s).

The drain lines connecting slideout-installed components, such as the kitchen sink and other optional equipment utilizing the coach water supply, are typically hard-plumbed within the slideout. The hard plumbing from the kitchen slideout connects to the hard plumbing from the tank using a braided drain line to ensure flexibility as the slideout extends and retracts. The fresh water plumbing lines are normally tied to the flexible drain pipe and extend and retract smoothly as the slideout travels.

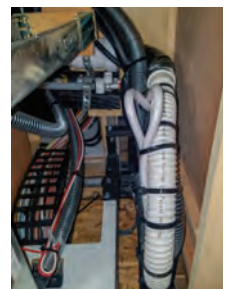

P-Traps and Waterless Traps

This article provides an overview and care and maintenance recommendations for traditional and waterless p-traps.

P-Traps

The sinks and shower drain have a water trap to prevent holding tank odors from entering the coach. These traps must have water in them in order to trap the odors. While traveling, the water may leave the P-Trap. While stored, the water may evaporate, allowing an odor to enter the coach. If this occurs, run water from the faucet into the drain, allowing water to fill the trap.

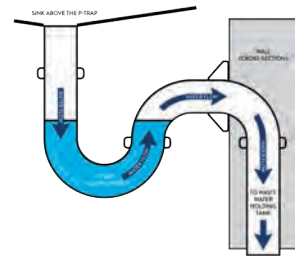

Waterless Traps

Some coach models with a rear shower may have waterless traps in lieu of conventional P-traps. Waterless traps are designed to allow water to drain and to prevent odor from entering the coach without the height requirements of the conventional p-trap. Pressure builds and the self-sealing valve opens as water drains from a fixture. The valve closes to form a tight seal after the water has completely drained from the sink or shower. No routine or seasonal maintenance is required for the waterless trap.

Foreign objects, such as hair, in the trap may allow odor to enter the coach and impede or slow water drainage and require occasional cleaning. When removing the waterless trap for cleaning, the ridges must be down and the direction of water flow must be correct when re-installed.

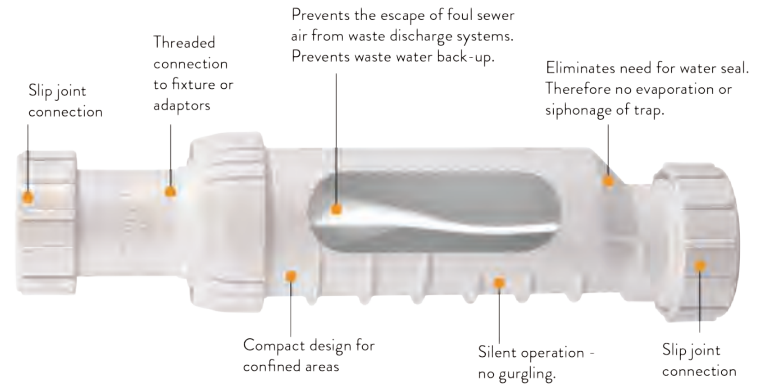

NOTICE
 Remove the waterless trap before using mechanical drain-cleaning devices. Waterless trap can be damaged.
 AD-125

⚠ IMPORTANT

If standing water occurs in your shower, do not attempt to unplug or open the drain with a coat hanger or a sewer snake. Before taking your coach to a service center, try leveling your coach so that the rear is raised slightly higher than the front. This may correct the condition and prevent drain-cleaning or a service repair. If this does not correct the issue, Newmar recommends taking your coach to a service center for drain-cleaning or repair.

Lift Pump Operation (SFA Saniflo Sanivite)

This article provides basic operation instructions for a Lift Pump (SFA Saniflo Sanivite). Certain floorplans may use a lift pump in locations where plumbing drains are too low or too far away for gravity drains to effectively reach the waste water holding tanks. The design is a small collection tank with an inlet from the sink or shower with a submersible pump to push the water out of the discharge to the holding tank.

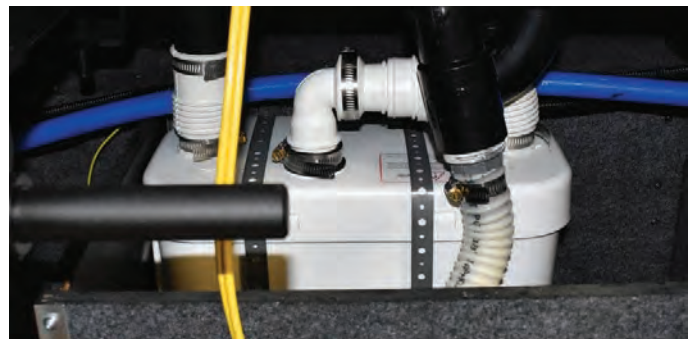

Note: Lift pumps operate on 120 volt power. The coach must be plugged into shore power or using the generator, or, when dry camping, the batteries must be charged and the inverter must be operational. Some coaches may have a separate small inverter just to operate the lift pump; however, most will share the inverter with other inverted circuits.

Note: On floorplans with lift pumps, follow proper winterization instructions to prevent the system from freezing.



Toilets

Toilet Overview, Care, and Maintenance

This article provides an overview of toilet operation and care and maintenance. “Go” in style and comfort, no matter where your travels may take you.

Waste Water Drain Lines

The drain lines are plumbed from the sinks, showers, and toilets are sloped to drain waste water to the grey or black tank.

Care and Maintenance

Before using the stool, treat the tank with water that is mixed with an odor-controlling chemical, which is readily available at any RV supply store. Mix as directed on the holding tank chemical package. After mixing and flushing the chemical mixture, the waste tank is ready for use. The stool should be cleaned regularly for maximum sanitation and operational efficiency.

When using your stool, it is wise to fill the bowl 3/4 full of water. This will help to wash the solids away from directly below the stool and to ensure complete dumping of the holding tank. After flushing, a small amount of water should remain in the bowl.

⚠ NOTICE

To prevent holding tank odors from entering the living space, make sure a small amount of water remains in the toilet bowl.

⚠ WARNING

Do not flush diaper wipes, feminine hygiene products, or any other products that would not be easily liquefied. Also avoid using holding tank deodorant capsules, as they may cause damage to the macerator. Damage resulting from flushing any materials or objects other than organic waste and toilet paper are not warrantable repairs.

⚠ IMPORTANT

These brief operation instructions are for quick reference only and should not take the place of the complete manual(s) provided by this product’s manufacturer. Refer to the corresponding links and files in Newgle for more details about your product.

⚠ IMPORTANT

Be careful not to spill the chemical on your hands, clothing, or the carpet, as it may cause a permanent stain.

⚠ CAUTION

Use only approved RV odor controlling chemicals in the holding tanks. Do not use chlorine or caustic chemicals like laundry bleach or drain-opening chemicals, as they will damage the seals in the toilet and dump valves. Products containing ammonia and petroleum may damage the ABS plastic holding tanks and seals.

⚠ IMPORTANT

Before adding water, consult the toilet manufacturer’s owner’s manual for the specific procedure relating to your system.

⚠ NOTICE

Residual water trickle in ceramic bowls: Due to integrated rim of this toilet bowl, water may continue to slowly trickle into toilet bowl for up to 20 minutes after flushing. If water trickle continues after 30 minutes, replace the water valve.

Standard Gravity-Discharge Toilets with Flush Pedal Operation (Dometic 300, 310, and 320 Series)

This article provides basic operation instructions for a Standard Gravity-Discharge Toilet with Flush Pedal (Dometic 300, 310, and 320 Series). Dometic 300, 310, and 320 series toilets provide lightweight, residential-size toilets for installation directly above a holding tank.

Adding Water To The Toilet Bowl

To add water to the toilet, press the flush pedal part of the way down. Water flows into the bowl while the flush ball remains closed. If the flush ball moves, let up on the pedal slightly. Adding water to an empty bowl helps prevent holding tank odors from entering the living space. Adding water is recommended prior to flushing solids and toilet paper.

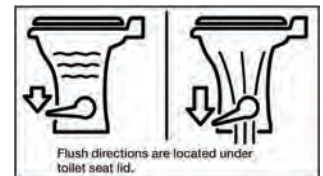

Flushing The Toilet

To flush, press the pedal down until it contacts the floor. Release the pedal after the complete flush.

- When flushing liquids, press the pedal for 1-2 seconds.
- When flushing solids, press the pedal until contents are rinsed from bowl. Flushing longer than necessary will cause holding tank to fill too quickly.

A small amount of water will collect in the bowl after a flush to create an airtight seal.

Source: Dometic 310 and 320 Series Gravity-Flush Toilet Instruction Manual

Macerator-Style Toilets with Flush Pedal Operation (Dometic 7600 Series)

This article provides basic operation instructions for a Macerator-Style Toilet with Flush Pedal (Dometic 7600 Series).

The Dometic MasterFlush 7600 series electric-flush toilet macerates waste and pumps it to a holding tank or other effluent storage or disposal system. Operated by a flush pedal, the toilet allows the user to add water to the bowl (before using or flushing) and to flush the toilet.

Adding Water To The Toilet Bowl

To add water to the toilet, press the flush pedal slightly. To avoid possible overflow, water flow will stop automatically if the pedal is pressed too long. More water is usually added only when flushing solids.

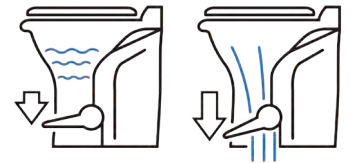

Flushing The Toilet

To flush, press the pedal down completely, then release it. This activates a powerful macerator pump that siphons water and waste from the toilet bowl, macerates and propels the effluent to the holding tank.

Changing Flush Modes

MasterFlush 7600 series toilets offer two flush settings to help manage water consumption:

1. Normal Flush: Uses 0.83 gallons per flush and adds water to the bowl after every flush.
2. Dry Bowl Flush: Uses 0.21 gallons per flush and does not add water to bowl after flush.
3. To change from Normal to Dry Bowl flush setting, press “Flush” pedal for about 10 seconds. Flush mode has been changed to Dry Bowl setting. Change mode to Normal flush by following the same procedure.

Source: Dometic 7600 Series MasterFlush Toilet Instruction Manual

Waste Water Holding Tanks

This article provides a basic overview of the waste water holding tanks. There are two separate waste systems: the gray tank system and the black tank system. Each tank has its own control valve, and both tanks drain through the sewer drain hose.

The waste drainage system was designed to provide adequate and safe storage and/or disposal of waste materials. The drainage system uses plastic piping and fittings connected to the sinks, toilet, and holding tanks to provide for their drainage to an outside termination. All waste water tanks are vented through the roof and covered with a vent cap. The coach should be reasonably level for best operation of the system.



Gray Water Holding Tank

The gray water holding tank is located in the underbelly of the coach, sometimes on top of the fresh water tank. It is primarily used for the drainage from the kitchen and bath sinks, shower, and the washing machine (if equipped).

Black Water Holding Tank

The black water holding tank is generally for sewage waste from the stool. It is typically located between the frame rails in the water compartment directly beneath standard flushing toilets. Macerator-style toilets can be installed away from the black tank.

Both tanks should be rinsed after dumping and treated with a waste tank additive to help break down and liquefy solid waste and help reduce odors. This chemical is readily available at any RV supply store.

Waste Water Disposal

Both of the holding tanks terminate in a valve arrangement that permits draining each tank separately or together. The valves that open to release the water are called gate valves. The blade that closed the opening in the sewer drain pipes is connected to the T-handle to release the contents of the tank(s) when pulled.

The sewer line must be securely capped during self-containment use to prevent leakage of waste material onto the ground or pavement.

Do not pull the holding tank gate valve open, or operate the electric dump valve switch (if equipped) when the protective cap is installed on the pipe. Always drain the tank into an acceptable sewer inlet or dump station.

⚠ CAUTION

The gray tank valve must be in the open position when operating the optional washing machine.

⚠ IMPORTANT

Be careful not to spill the chemical on your hands, clothing, or the carpet as it may cause a permanent stain.

⚠ CAUTION

Use only approved RV odor-controlling chemicals in the holding tanks. Products containing ammonia and petroleum will damage the ABS plastic holding tanks and seals.



⚠ CAUTION

Keep drain valve closed to minimize the presence of sewer gases. Sewer gases can be present when RV is connected to campground sewage hookup. Can lead to illness or personal injury.

AD-120



⚠ WARNING

Holding tanks are an enclosed sewer system and must be drained into an approved dump station. Both black and gray water holding tanks must be drained and rinsed thoroughly on a regular basis in order to prevent the accumulation of harmful or toxic materials.

How To Drain The Waste Water Holding Tanks

The holding tanks should only be drained when they are at least three-fourths full, to provide sufficient water to allow the complete flushing of waste materials in the drain lines and hose. If the tanks are not three-fourths full, add enough water to allow for sufficient flushing. Whenever possible, drain the holding tanks prior to traveling. The carrying capacity of your unit will be reduced if water is left in the black or gray tanks.

To empty the waste water tanks, follow the procedure below, depending on the type of waste system your coach uses. It is recommended to drain the black water tank before the gray water tank.

DRAINING THE WASTE WATER TANKS ON A COACH WITH A STANDARD GRAVITY DRAIN AND DUMP SYSTEM

1. Connect the adapter to the drain hose.
2. Unscrew the drain cap, and connect the hose with the adapter to the drain fitting. Support the hose as needed for optimal flow.
3. Open the gate valve all the way by pulling on the T-handle. The tank will start to drain as soon as the T-handle is pulled.

4. After you have drained the black water tank, immediately drain the gray water tank, allowing the water from the gray tank to wash the black water residue from the drain lines and hose.
5. When both of the tanks are empty, flush them with fresh water before you close the valves. Flush the gray tanks by pouring a couple of gallons of water into a sink drain. The drain outlet is engineered for quick release of the drain hose adapter.
6. Always close the gate valves and secure the end cap to prevent leakage while in transit.
7. Add a holding tank deodorant to help control the odor and break down the solid waste.

DRAINING THE WASTE WATER TANKS ON A COACH WITH A MACERATOR WASTE SYSTEM (SANI-CON)

- The Sani-Con macerating waste system provides the following convenient features:
- Provides a sanitary method for discharging liquid waste from the RV by easily and quickly emptying waste-water from the RV's holding tanks, without relying on gravity.
- The macerating system pumps liquid waste from holding tanks and does not rely on gravity.
- The macerator is designed to process human waste and toilet tissue, making the Sani-Con ideal for black water, as well as gray water, discharges.

1. Make sure the black and gray water dump valves are closed.
2. Point the hose nozzle upward, and remove the nozzle cap.
3. Insert the nozzle into the sewer connection.
4. Open the gray water dump valve, and run the macerator pump for a few seconds to confirm that the system is operating correctly.

 **IMPORTANT**

If there is a problem with the connection, or if the system is not functioning correctly, the macerator may need to be cleaned or serviced.

5. Shut the gray water dump valve, and turn off the pump switch once you have determined that there are no problems.
6. Open the black water dump valve, and turn on the macerator pump switch.
7. Monitor the tank as it empties. The pump will run louder when the tank is empty.
8. Turn off the pump switch once the tank is empty.
9. Flush the black tank, and operate the macerator while it is flushing.
10. Turn off the flush system, then turn off the macerator.

11. Close the black water dump valve.
12. Add tank chemicals and the amount of water recommended by the chemical manufacturer.
13. Drain the gray tank next to help flush out the macerator and sewer hose.

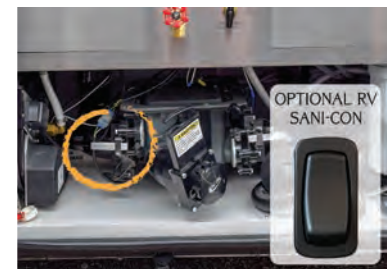

14. Open the gray water dump valve.
15. Turn on the pump switch.
16. Monitor the tank as it empties. The pump will run louder when the tank is empty.
17. Turn off the pump switch once the tank is empty.
18. Flush the gray tank, and operate the macerator while it is flushing (if equipped).
19. Turn off the flush system, then turn off the macerator.



20. Close the gray water dump valve.
21. Place the cap on the hose and store it.
22. Add tank chemicals and the amount of water recommended by the chemical manufacturer.

Camping With Sewer Hook-Up

When camping at parks with sewer hook-up, it is important to keep the black water holding tank gate valve closed at all times, except when dumping. The gray tank can be kept open while hooked to a sewer connection, but the black water tank must be kept closed. This is done so that an ample supply of liquid remains in the tank to provide a smooth flow through the gate and drain valve when dumping.

Sufficient liquid in the tank causes a swirling action that should take any accumulated solid wastes with it. Accumulation of solid wastes in the black water tank can be avoided by keeping the gate valve closed when connected to the sewer hook-up. If the valve is left open, solid wastes may accumulate in the tank. This may eventually result in costly repairs.

Holding Tank Rinse - No Fuss Flush

This article provides an overview of the holding tank rinse - no fuss flush. The coach may be equipped with a flushing system for the holding tank(s). When draining your sewer tank, attach a water hose to the sewer spray hookup. After the tank is drained, leave the gate valve open, and open the water valve to allow water to spray inside the sewage tank.

Allow the water to rinse the tank for a minimum of three to five minutes to ensure it is clean. This should flush the inside of the tank of any debris that may be left inside.

Next, disconnect the freshwater hose and close the gate valve. If there are any solids still left inside the tank, fill the sewage tank with approximately ten gallons of water through the stool. As you travel, the agitation of the water should help liquefy any solids left in the tank. You can dump the sewage tank again at your next destination.

Select coaches may also have a tank flush on the grey water tank. Follow the same flush procedure by leaving the grey tank gate valve open while flushing.

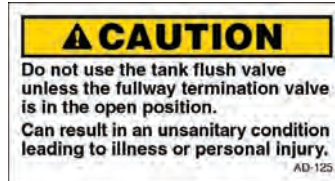

On coaches equipped with tank rinse low point drain(s), turning the tank rinse drain valve to the “open” position will remove pressure and drain the tank rinse line. When finished using the tank rinse, it is recommended to turn off the water supply to the tank rinse connection. Open the valve, and drain off the pressure in the line before disconnecting the water hose.

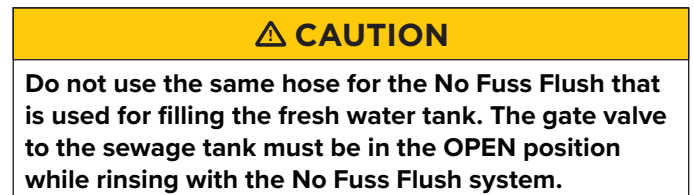
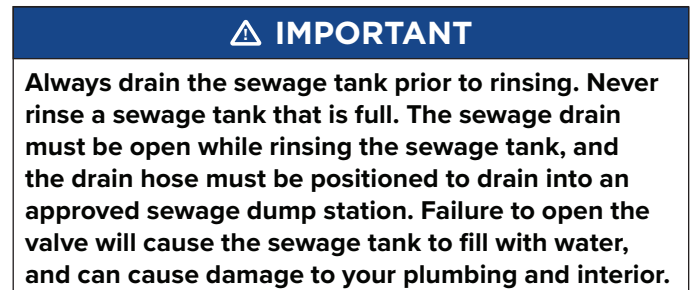



SLIDEOUTS

Extending and Retracting the Slideouts

This article provides step-by-step instructions for leveling the coach and operating the slideouts.

Before Extending The Slideouts

1. Park the coach on a reasonably level campsite.
2. Leave the coach at ride-height with air in the air bags (if equipped with air suspension) or on normal suspension (coaches without air suspension).
3. Plug the coach into shore power (if available) or start the generator to increase the voltage for better slideout operation.
4. For a full wall slideout, visually inspect the front vertical trim for adequate clearance. The spacing should look even from top to bottom. (See image.)
5. Verify that the path of the slideout is unobstructed and free from any surrounding objects, both inside and outside of the coach.
6. Once the appropriate conditions are met, follow the operating instructions posted in your coach to extend the slideouts.
7. Deploy the leveling jacks.

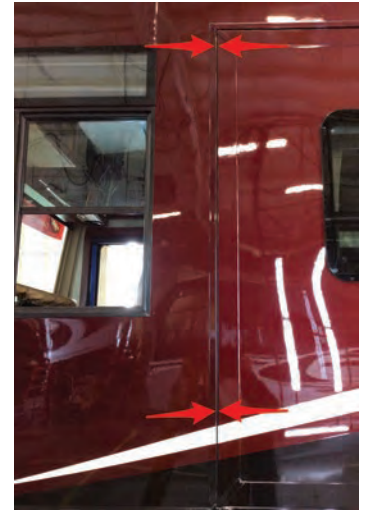

IMPORTANT

In the unlikely occasion that the slideout trim has inadequate clearances, try leveling or repositioning the coach and rechecking the clearances before extending the slideout.

Before Retracting The Slideouts

1. Retract the leveling jacks.
2. Start the coach.
3. Allow the coach air suspension to fill and return to ride height (units without air suspension will return to normal suspension).
4. Turn the engine off.
5. For a full wall slideout, visually inspect the front vertical trim for adequate clearance. The spacing should look even from top to bottom. (See image for reference.)
6. Verify that the path of the slideout is unobstructed and free from any surrounding objects, both inside and outside of the coach. This includes any water or debris that may have collected on the slideout roof or the topper awning.
7. Retract the slideouts.
8. Inspect all slideouts for complete retraction.
9. If the coach is equipped with manual lock arms, make sure to lock them.
10. Unplug the coach from shore power when you are ready to depart.

IMPORTANT

Debris left on the roof or topper may prevent the slideout from sealing properly when retracted, as well as prevent the mechanical lock arms from closing properly when the slideout is extended.

IMPORTANT

In the unlikely occasion that the slideout trim has inadequate clearances, try leveling or repositioning the coach and rechecking the clearances before retracting the slideout.

Electric Slideout Operation

This article provides basic operation instructions for an electric slideout.

Electric Slideout Switches



ELECTRIC BEDROOM SLIDEOUTS

The operating switch for the bedroom slideout is usually located on the bedroom wall. If there is a full wall slideout on the driver side of the coach, the switch may be located on the wall that separates the bedroom from the living room.

ELECTRIC KITCHEN SLIDEOUTS

The operating switch for the kitchen slideout is usually located in the overhead cabinet above the driver or passenger chair or the overhead cabinet above the entrance door.

Electric Slideout Operation

In order to operate a slideout with the required voltage levels, batteries should be fully charged, the generator should be powered on, or the coach should be connected to shore power. This maintains the voltage levels required to operate the slideouts.

- On diesel coach slideouts: Park brake must be engaged before operation the slideout rooms. The slideout room will not operate when Park Brake is released.
- On gas coach slideouts: Ignition key must be turned off or in accessories position before operating the slideouts. The slideout rooms will not operate when the ignition key is in the ignition ON position.

EXTENDING THE SLIDEOUT ROOM

1. Slideout end windows must be shut before moving room.
2. Look for and remove any obstructions before moving room.
3. Caution on motorhomes: Move driver seat forward before moving room.
4. If rooms are equipped with Manual Lock-Arms, be sure to release arms before running room out.
5. Press and hold the appropriate slideout switch until the slideout is fully extended and stops moving.
6. Release the switch. Note: The slideout room movement can be stopped at any time by releasing the switch.

ELECTRIC WARDROBE SLIDEOUTS

The operating switch for the wardrobe slideout is usually located in the bedroom, on the wall beside the corresponding slideout.

ELECTRIC FLAT FLOOR SLIDEOUTS

Newmar pushed the RV industry forward by introducing the first flat floor slideouts. We continue to lead today with our patented flat floor slideout designs. The same insight and experience that helped us improve slideout functionality has also helped us improve slideout quality.

The operating switch for the flat floor slideout is usually located in the overhead cabinet above the driver or passenger chair or the overhead cabinet above the entrance door.

ELECTRIC FULL WALL SLIDEOUTS

Most electric full wall slideouts extend from the living area to the master bathroom in a Newmar coach.

⚠ IMPORTANT

Read entire slideout room instructions posted in your coach before extending or retracting the slideout.

RETRACTING THE SLIDEOUT ROOM

1. Slideout end windows must be shut before moving room.
2. Look for and remove any obstructions before moving room.
3. Caution on motorhomes: Move driver seat forward before moving room.
4. Press and hold the appropriate slideout switch until the slideout room is fully retracted and stops moving.
5. Release the switch. Note: The slideout room movement can be stopped at any time by releasing the switch.
6. If rooms are equipped with Manual Lock Arms, be sure to engage lock arm when rooms are in and before moving coach.

Manual Operation of Room

Refer to the Manual Operation Instructions located on the kitchen overhead cabinet.

INSTRUCTIONS

READ ENTIRE SLIDE-OUT ROOM INSTRUCTIONS BEFORE MOVING SLIDE-OUT ROOM

GENERAL INSTRUCTIONS:

- 1) On Diesel coach side-out: Park Brake must be engaged before operating the slide-out rooms. The slide-out rooms will not operate when the Park Brake is released.
- 2) On Gas coach side-outs: Ignition key must be turned off or in accessories position before operating the slide-outs. The slide-outs rooms will not operate when the Ignition key is in the Ignition ON position.

Extending Slide-out Room:

- 1) Slide-out end windows must be shut before moving room.
- 2) Look for and remove any obstructions before moving room.
- 3) **CAUTION ON MOTORHOMES:** Move driver seat forward before moving room.
- 4) If rooms are equipped with Manual Lock-Arms, be sure to release arms before running room out.
- 5) Press and hold the appropriate slide-out switch until the slide-out is fully extended and stops moving.
- 6) Release the switch. Note: The slide-out room movement can be stopped at any time by releasing the switch.

Retracting Slide-out Room:

- 1) Slide-out end windows must be shut before moving room.
- 2) Look for and remove any obstructions before moving room.
- 3) **CAUTION ON MOTORHOMES:** Move driver seat forward before moving room.
- 4) Press and hold the appropriate slide-out switch until the slide-out room is fully retracted and stops moving.
- 5) Release the switch. Note: The slide-out room movement can be stopped at any time by releasing the switch.
- 6) If rooms are equipped with Manual Lock-Arms, be sure to engage lock arm when rooms are in and before moving coach.

MANUAL OPERATION OF ROOM:
Refer to the MANUAL OPERATION INSTRUCTIONS located on the kitchen overhead cabinet.

Revision 01: 2018

INSTRUCTIONS

MANUAL SLIDE-OUT ROOM EXTENSION AND RETRACTING INSTRUCTIONS

READ ENTIRE SLIDE-OUT ROOM INSTRUCTIONS BEFORE MOVING SLIDE-OUT ROOM

MOTORS WITHOUT MANUAL DRIVE NUT:

- 1) Manual lock arms must be released from locked position prior to extending the room.
- 2) Access must be gained to the motor attachment bolts. Remove the bolts and slide the motor off the square part of the shaft.
- 3) Once the motor is off, the slide out can be pushed manually in or out.

MOTORS WITH MANUAL DRIVE NUT:

If the unit is equipped with the shaft through the gearbox motor which is mounted near the center of the slide-out room, use the following directions:

- 1) Manual lock arms and power locks must be released from locked position prior to extending the room.
- 2) Access must be gained to the slide out motor located in the center of the slide out room.
- 3) Releasing the motor's 'Electro-Mechanical Brake': At the end of the motor remove the black plastic cover. Remove the tie-wrap and pull the cover off the motor. You must apply a 12 volt power source to release the brake. A source such as; a charged 9V battery will work. To apply the power source, separate the electrical connectors between the motor and brake and attach the connectors which lead to the brake to your power source. This will release the brake and allow manual cranking.
- 4) The manual extension or retraction requires only a 5/8" socket and ratchet wrench. By placing the socket on the 5/8" hex nut located on the gear box of the 900 motor, the slide-out can be moved in either direction by turning the hex nut.
- 5) If the slide-out does not move by using the hex nut, the room can be extended or retracted by using the procedure described for motors without the manual drive nut.

MANUAL OPERATION OF HWH ROOM:
Refer to the MANUAL OPERATION INSTRUCTIONS located in owners manual.

Revision 01: 2018

Slideout Safety

⚠ WARNING

Do not allow children to operate the slideout. Do not allow any person to place their arms, legs, body or head between any pinch point of the lock arms, slideout fascia, interior walls, exterior walls, objects, or floor as serious injury or death could result. Any adjustments, or repairs, must be made only by "Newmar" qualified personnel. Always check the interior and exterior of the coach for objects, or persons, that are in the path of the slideout when extending or retracting the room. Always check the room to be sure any objects, or debris, are removed before retracting the room. Operator must remain continually in control of the slideout room control switch while the room is moving in or out.

⚠ WARNING

Be sure that the driver's seat is in the forward position before activating the slideout room.

⚠ WARNING

Do not allow children to operate the slide-out. Do not allow any person to place their arms, legs, body or head between any pinch point of the lock arms, slide-out fascia, interior walls, exterior walls, objects, or floor as serious injury or death could result. Any adjustments, or repairs, must be made only by "NEWMAR" qualified personnel. Always check the interior and exterior of the coach for objects, or persons, that are in the path of the slide-out when extending or retracting the room. Always check the roof to be sure any objects, or debris, are removed before retracting the room. Operator must remain continually in control of the slide-out room control switch while the room is moving in or out.

(H-12)

⚠ WARNING

Be sure that driver's seat is in the forward position before activating the slide out room.

NE-043

Electric Slideout Maintenance

This article provides care and maintenance information for the electric slideout. Electric slideout drive mechanisms do not require lubrication as part of the scheduled maintenance. Some noise is normal during extension and retraction from the various moving parts and seals.

If lubrication is desired, Newmar recommends using a light coat of LPS 1 Greaseless Lubricant, which provides a dry, thin lubricating film that is resistant to dirt and dust buildup.

In addition, the torque on all electric slideout motor mounting bolts should be checked annually by an Authorized Newmar Service Center.

⚠ IMPORTANT

Newmar does not recommend the use of grease, silicone, or WD-40 on the slideout tubes or chains, as these products tend to collect dirt and dust.

How to Manually Retract an Electric Bedroom Slideout

This article provides three possible methods for manually retracting a bedroom slideout if it will not retract on its own.

⚠ IMPORTANT

Prior to proceeding with a manual retraction procedure, make sure the ignition key is in the off position and the park brake is set. Then, try retracting the slideout again, as some controllers require the ignition to be off, and others require the park brake to be set.

⚠ WARNING

The manual retraction procedures are for emergency use only. These procedures bypass all normal safety features. It is the responsibility of the person(s) performing the procedure to watch for moving parts and pinch points in order to avoid injury.

Procedure 1

This method requires the motor and gear box to be operational. This procedure bypasses the slide controller, switch, and the wiring. If battery power is unavailable or the motor/gear box is inoperable, move to procedure two.

⚠ IMPORTANT

This procedure can be performed on any single motor electric slideout.

1. Disconnect the red and black wires connected to the motor.
2. Using the the wires attached to the motor, connect to a 12 volt cordless battery to retract the slideout. If the wire polarity is reversed, the slideout will extend instead of retract.

⚠ IMPORTANT

If the slideout motor has a brake installed, you must also hook one brake wire to the battery with the red slideout motor wire and one with the black slideout motor wire.

1. Disconnect the wire(s) from the cordless battery pack.

Procedure 2

Determine which slideout setup your coach utilizes, and follow the steps below pertaining to your specific setup.

CONVENTIONAL BEDROOM SLIDEOUT SETUP

⚠ IMPORTANT

This procedure can be performed on coaches with a slideout motor located under the bed frame.

This method is the fastest one if the motor or gears fail, as it does not require battery power. However, this method requires a significant amount of manpower to push in the slideout.

1. Open the lid of the bed box.
2. Loosen the trantorque bushing.
3. Push the room into the retracted position.
4. Retighten the trantorque bushing.
5. Take the coach to an authorized service center for diagnosis and repair.

-or-

1. Open the lid of the bed box.
2. Loosen the trantorque bushing.
3. Turn the shaft with a wrench until the slideout reaches the retracted position. Make sure you do not damage the shaft with the wrench.
4. Retighten the trantorque bushing.
5. Take the coach to an authorized service center for diagnosis and repair.

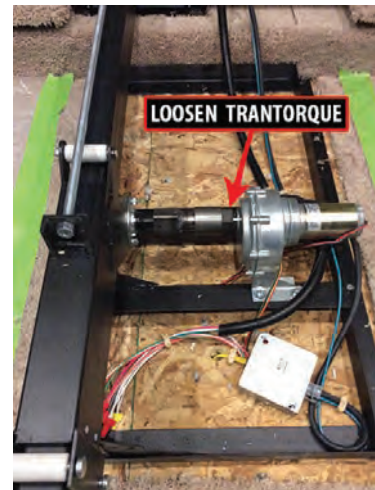

R-3 BEDROOM SLIDEOUT WITH TRANTORQUE AT MOTOR

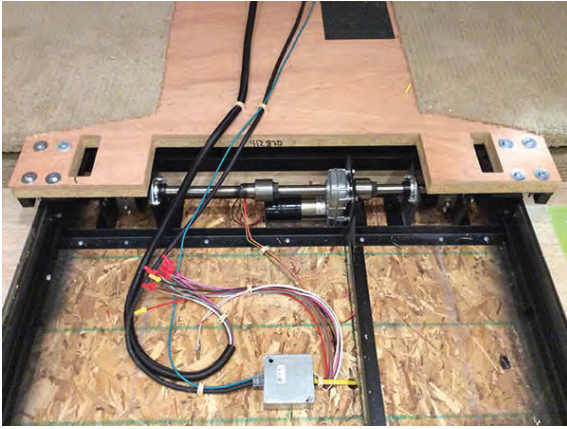

This method is the fastest one if the motor or gears fail, as it does not require battery power. However, this method requires a significant amount of manpower to push in the slideout.

1. Loosen the trantorque bushing at the slideout motor, allowing the slideout to extend and retract freely.
2. Push the room into the retracted position with the assistance of several people. This procedure can be performed on any electric slideout.
3. Remove the motor's black access cover, and tighten the trantorque bushing to 175 ft. lbs. This procedure can be performed on all electric slideouts.

IMPORTANT

This procedure can be performed on coaches without a square shaft and utilizes a slideout motor located under the slideout floor near the sidewall.

R-3 BEDROOM SLIDEOUT SETUP WITH SQUARE SHAFT

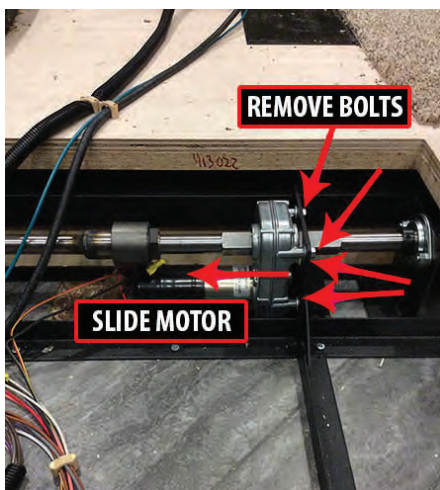

IF THE SLIDEOUT IS STUCK IN THE EXTENDED POSITION

1. Remove the four mounting bolts, and move over the slideout motor until it disengages from the square shaft.
2. Manually push the room in or out.

WITH MANUAL LOCK ARMS

3. Lock the room with manual lock arms (if equipped).
4. Take the coach to an authorized service center for diagnosis and repair.

WITH MECHANICAL LOCK ARMS

3. Slide the motor back over onto the square shaft and reinstall the four mounting bolts.
4. Wedge a 2x4" board between the slideout fascia and the exterior wall at the front and back of the slideout roof to hold the slideout in the retracted position.
5. Take the coach to an authorized service center for diagnosis and repair.

IF THE SLIDEOUT IS STUCK IN THE RETRACTED POSITION

1. If the motor fails while the slideout is in the retracted position, take the coach to an authorized service center for diagnosis and repair.

IMPORTANT

This procedure can be performed on coaches with a brake on the slideout motor.

Procedure 3

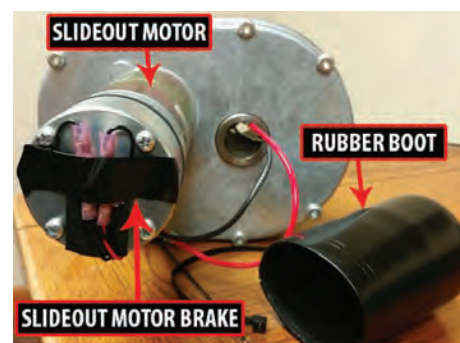

Only a few tools are necessary to complete this procedure; however, it requires the gear box to be operational. Follow the steps to manually retract the slideout by removing the brake and turning the shaft.

1. First, locate the strap that secures the rubber boot on the outside of the motor.
2. Remove the strap, and pull off the rubber boot, removing it from the motor.

3. Remove the four screws from under the rubber boot on the brake.
4. Once the brake is removed, use a wrench to turn the shaft to retract the slideout.

⚠ IMPORTANT

Make sure you do not damage portions of the shaft that will slide through the motor, trantorque, bearing, and cog wheels.

5. After the slideout is fully retracted, reinstall the brake.

⚠ NOTICE

Depending on the year, model, and floorplan of the coach, the exact slideout motor(s) location may vary. Generally, they may be accessed from under the bed.



How to Manually Retract an Electric Flat Floor Slideout

If the electric flat floor slideout will not retract on its own, there are three possible methods for retracting it manually.

⚠ IMPORTANT

Prior to proceeding with a manual retraction procedure, make sure the ignition key is in the off position and the park brake is set. Then, try retracting the slideout again, as some controllers require the ignition to be off, and others require the park brake to be set.

⚠ WARNING

The manual retraction procedures are for emergency use only. These procedures bypass all normal safety features. It is the responsibility of the person(s) performing the procedure to watch for moving parts and pinch points in order to avoid injury.

Manual Retraction - Method 1

This method is quick, but requires the motor and gear box to be operational. This procedure bypasses the slide controller, switch, and the wiring.

⚠ IMPORTANT

This procedure is possible to perform on any single motor electric slideout.

1. Disconnect the red and black wires attached to the motor from the coach wiring.
2. Using the the wires attached to the motor, connect to a 12 volt cordless battery to retract the slideout. If the wire polarity is reversed, the slideout will extend instead of retract.

⚠ IMPORTANT

If the slideout motor has a brake installed, you must also hook one brake wire to the battery with the red slideout motor wire and one with the black slideout motor wire.

1. Disconnect the wire(s) from the cordless battery pack.
2. Take the coach to an authorized service center for diagnosis and repair.

Manual Retraction - Method 2

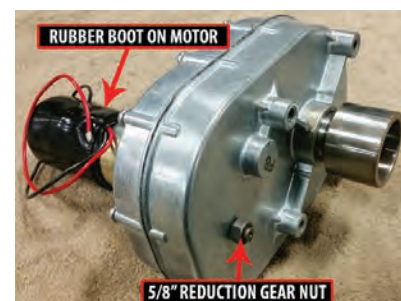

The second option takes longer; however, only a screw gun or ratchet is required. Follow the steps to manually retract the slideout using the gear reduction nuts. This method may be used on both the round and square shaft motors.

1. First, locate the strap that secures the rubber boot on the outside of the motor.

Manual Retraction - Method 3

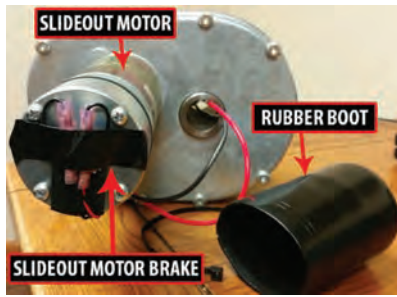

1. Remove the strap, and pull off the rubber boot, removing it from the motor.

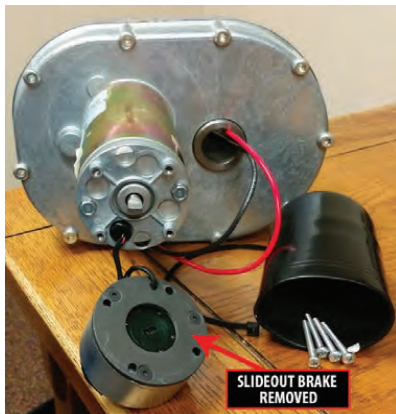

2. Remove the four screws from under the rubber boot on the brake.

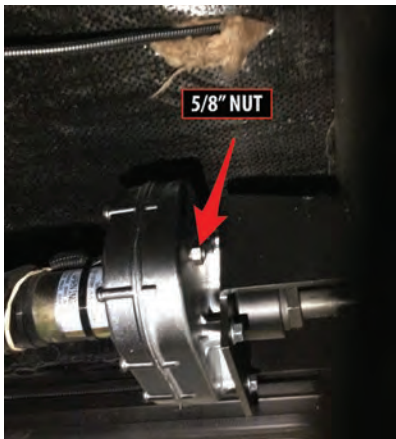

4. Once the brake is removed, use a screw gun or a ratchet with a 5/8" socket to turn the gear reduction nut to retract the slideout.

IMPORTANT

Screw guns are recommended due to the major reduction in the gears. It will take many revolutions of the gear reduction nut to retract the slideout.

5. After the slideout is fully retracted, reinstall the brake.
6. Take the coach to an authorized service center for diagnosis and repair.



This method requires a significant amount of manpower and is not applicable to the flat floor slide rooms with a square shaft drive motor because there is no trantorque at the motor.

1. Loosen the trantorque bushing at the slideout motor, allowing the slideout to extend and retract freely.
2. Now the room can be pushed in manually with the assistance of several people.
3. After the slideout has been pushed in, tighten the trantorque bushing to 175 ft. lbs.

NOTICE

Depending on the year, model, and floorplan of the coach, the exact slideout motor(s) location may vary. Generally, they may be accessed from under the slideout in the compartment area.

How to Manually Retract an Electric Full Wall Slideout

This article provides step-by-step instructions for manually retracting a full wall slideout when it will not retract on its own.

⚠ IMPORTANT

Prior to proceeding with a manual retraction procedure, make sure the ignition key is in the off position and the park brake is set. Then, try retracting the slideout again, as some controllers require the ignition to be off, and others require the park brake to be set.

⚠ WARNING

The manual retraction procedures are for emergency use only. These procedures bypass all normal safety features. It is the responsibility of the person(s) performing the procedure to watch for moving parts and pinch points in order to avoid injury.

Slideout motor location varies with coach length and floorplan. Typically the motor(s) are found under the slideout in the storage compartments just under the floor. The motor(s) may also be located above the wheel well behind a cover. If you find the slideout drive tubes, follow the round or square drive shaft(s) to the motor assembly. There is typically one motor in the front and one motor in the back of the coach.

If the full wall slideout will not retract on its own, there are two possible methods for retracting it manually. The first option takes longer; however, only a screw gun or ratchet is required. The second option is quicker, but requires a significant amount of manpower and is not applicable to square drive motors.

Manual Retraction - Method 1

This procedure will work on both round and square shaft motors.

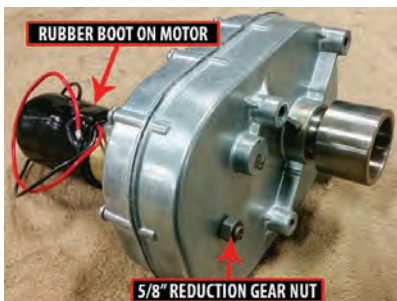

Follow the steps to manually retract the slideout using the gear reduction nuts.

1. First, locate the strap that secures the rubber boot on the outside of the motor.

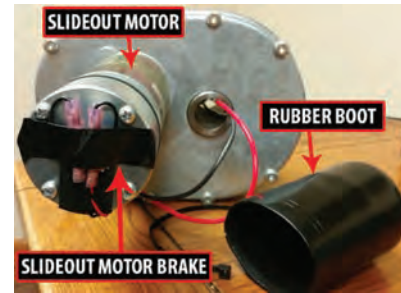

2. Remove the strap, and pull off the rubber boot, removing it from the motor.

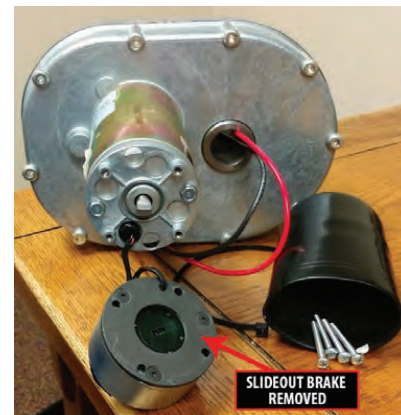

3. Remove the four screws from under the rubber boot on the brake.
4. Once the brake is removed, repeat the process for the second motor.
5. Use a screw gun or a ratchet with a 5/8" socket to turn the gear reduction nut to retract the slideout.

⚠ IMPORTANT

This process will need to be done in an alternating sequence when more than one motor is used. This is necessary to prevent the room from binding, unless you have a second person to perform the retraction procedure on the second motor at an equal retraction speed.

⚠ IMPORTANT

Screw guns are recommended due to the major reduction in the gears. It will take many revolutions of the gear reduction nut to retract the slideout.

6. After the slideout is fully retracted, reinstall the brake.
7. Take the coach to an authorized service center for diagnosis and repair.

Manual Retraction - Method 2

This procedure will not work on square shaft motors because there is no trantorque bushing at the motor.

This will be the hardest of the two options for full wall slideout manual retraction, as it requires assistance from several people as noted below. Follow the steps to retract the full wall slideout manually.

1. Loosen the trantorque bushing at each slideout motor, allowing the slideout to extend and retract freely. There are two motors on a full wall slideout, and both trantorque bushings will need to be loosened.
2. Now the room can be pushed in manually with the assistance of several people, as the full wall slideout will need to be pushed up the ramp onto the floor.
3. After the slideout has been pushed in, tighten the trantorque bushings to 175 ft. lbs.

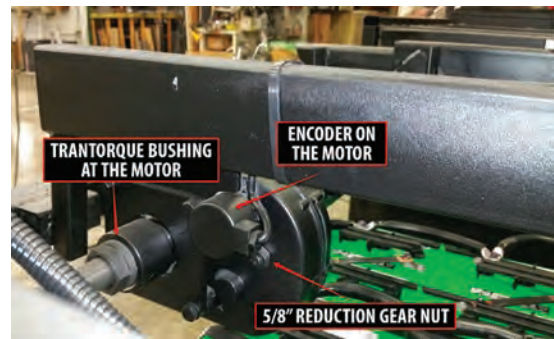

NOTICE

Depending on the year, model, and floorplan of the coach, the exact slideout motor(s) location may vary. Generally, they may be accessed from under the slideout in the compartment area. Some motors may also be located in the wheel well area under a cover.

How to Manually Retract an Electric Kitchen Slideout

This article provides step-by-step instructions for manually retracting an electric kitchen slideout when it will not retract on its own.

IMPORTANT

Prior to proceeding with a manual retraction procedure, make sure the ignition key is in the off position and the park brake is set. Then, try retracting the slideout again, as some controllers require the ignition to be off, and others require the park brake to be set.

If the kitchen slideout will not retract on its own, there are a few possible methods for retracting it manually.

Manual Retraction - Method 1

This procedure is not recommended for slideouts with more than one motor. Method one is quick, but requires the motor and gear box to be operational. This procedure bypasses the slide controller, switch, and the wiring.

NOTICE

This method can be performed on any single motor electric slideout.

Disconnect red and black wires that are connected to motor. Using the the wires attached to the motor, connect to a 12 volt cordless battery to retract the slideout. If wire polarity is reversed, the slideout will extend instead of retract. Disconnect the wire(s) from the cordless battery pack.

IMPORTANT

If the slideout motor has a brake installed, you must also hook one brake wire to the battery with the red slideout motor wire and one with the black slideout motor wire.

WARNING

The manual retraction procedures are for emergency use only. These procedures bypass all normal safety features. It is the responsibility of the person(s) performing the procedure to watch for moving parts and pinch points in order to avoid injury.

Manual Retraction - Method 2

Method two is the fastest method without using battery power, and the most practical if the motor or gears fail. This method requires a significant amount of manpower to push in the slideout.

COACHES WITH A TRANRTORQUE BUSHING AND ROUND SHAFT



1. Loosen the trantorque bushing(s) at the slideout motor(s), allowing the slideout to extend and retract freely.
2. Now the room can be pushed in manually with the assistance of several people.
3. After the slideout has been pushed in, tighten the trantorque bushing to 175 FT Lbs.

COACHES WITHOUT A TRANTORQUE BUSHING AND WITH SQUARE SHAFT

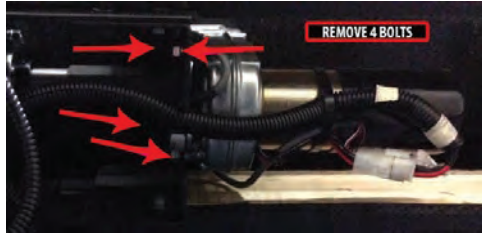

1. Remove the four motor mounting bolts.
2. Slide the motor(s) off of the square shaft. Due to clearance issues on some floorplans, it may be necessary to remove the brake to gain enough clearance to slide the motor off of the shaft.
3. Now the room can be pushed in manually with the assistance of several people.
4. Reinstall the motor, motor mounting bolts, and the brake (if it was removed).
5. Take the coach to an authorized service center for diagnosis and repair.

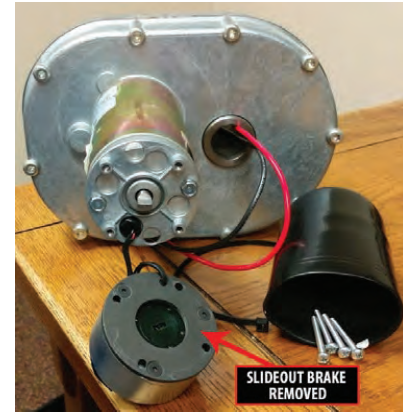

3. Remove the four screws from under the rubber boot on the brake.
4. Once the brake is removed, use a wrench to turn the shaft(s) to retract the slideout.
5. If the slideout is equipped with two motors, it will be necessary to remove both brakes and alternate the procedure in small increments so the slideout is not forced into a bind.

Manual Retraction - Method 3

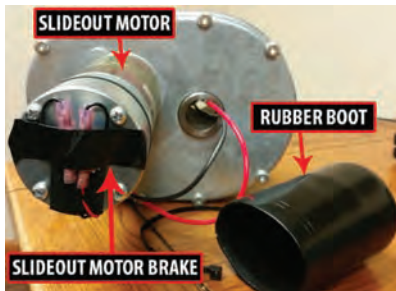

Method three takes longer; however, only a few tools will be needed. This procedure requires the gear box to be operational. Follow the steps to manually retract the slideout using wrench(s).

1. First, locate the strap that secures the rubber boot on the outside of the motor.
2. Remove the strap, and pull off the rubber boot to remove it from the motor.

⚠ IMPORTANT

When using a wrench to retract the slideout, make sure you do not damage the portion of the shaft that will slide through the motor, trantorque, bearing, and cog wheels.

6. After the slideout is fully retracted, reinstall the brake(s).
7. Take the coach to an authorized service center for diagnosis and repair.

⚠ NOTICE

Depending on the year, model, and floorplan of the coach, the exact slideout motor(s) location may vary. Generally, they may be accessed from under the slideout in the compartment area.

How to Manually Retract an Electric Wardrobe Slideout

This article provides step-by-step instructions for manually retracting an electric wardrobe slideout when it will not retract on its own.

⚠ IMPORTANT

Prior to proceeding with a manual retraction procedure, make sure the ignition key is in the off position and the park brake is set. Then, try retracting the slideout again, as some controllers require the ignition to be off, and others require the park brake to be set.

⚠ WARNING

The manual retraction procedures are for emergency use only. These procedures bypass all normal safety features. It is the responsibility of the person(s) performing the procedure to watch for moving parts and pinch points in order to avoid injury.

Manual Retraction - Method 1

This method is quick, but requires the motor and gear box to be operational. This procedure bypasses the slide controller, switch, and the wiring. If battery power is unavailable or the motor/gear box is inoperable, proceed to the second method.

1. Disconnect the red and black wires attached to the motor from the coach wiring.
2. Using the the wires attached to the motor, connect to a 12 volt cordless battery to retract the slideout. If the wire polarity is reversed, the slideout will extend instead of retract.

IMPORTANT

This procedure is possible to perform on any single motor electric slideout.

IMPORTANT

If the slideout motor has a brake installed, you must also hook one brake wire to the battery with the red slideout motor wire and one with the black slideout motor wire.

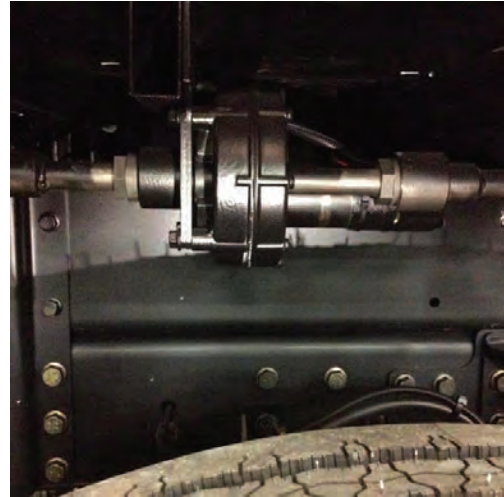

3. Disconnect the wire(s) from the cordless battery pack.
4. Take the coach to an authorized service center for diagnosis and repair.

Manual Retraction - Method 2

Determine which slideout setup your coach utilizes, and follow the steps below pertaining to your specific setup.

WARDROBE SLIDEOUT MOTOR WITH TRANTORQUE AND ROUND SHAFT

This method is the fastest one if the motor or gears fail, as it does not require battery power. However, this method requires a significant amount of manpower to push in the slideout.

1. Locate the slideout motor.
 2. Remove the covers from the motor if it is located in the wheel well area.
 3. Loosen the trantorque bushing.
 4. Push the room into the retracted position.
 5. Retighten the trantorque bushing (175 ft. lbs. for 1" shafts or 145 ft. lbs. for 3/4" shafts).
 6. Reinstall any removed covers.
- or-
1. Locate the slideout motor.
 2. Remove the covers from the motor if it is located in the wheel well area.
 3. Loosen the trantorque bushing.
 4. Turn the shaft with a wrench until the slideout reaches the retracted position. Make sure you do not damage the shaft with the wrench.
 5. Retighten the trantorque bushing (175 ft. lbs. for 1" shafts or 145 ft. lbs. for 3/4" shafts).
 6. Reinstall any removed covers.
 7. Take the coach to an authorized service center for diagnosis and repair.



WARDROBE SLIDEOUT MOTOR WITH SQUARE SHAFT

IF THE SLIDEOUT IS STUCK IN THE EXTENDED POSITION

1. Remove the four mounting bolts, and move over the slideout motor until it disengages from the square shaft.
2. Manually push the room in or out, or use a wrench to rotate the shaft. Make sure you do not damage the shaft with the wrench.

WITH MANUAL LOCK ARMS

3. Lock the room with manual lock arms (if equipped).
4. Take the coach to an authorized service center for diagnosis and repair.

WITH MECHANICAL LOCK ARMS

3. Slide the motor back over onto the square shaft, and reinstall the four mounting bolts.
4. Wedge a 2x4" board between the slideout fascia and the exterior wall at the front and back of the slideout roof to hold the slideout in the retracted position.
5. Take the coach to an authorized service center for diagnosis and repair.



⚠ NOTICE

Depending on the year, model, and floorplan of the coach, the exact slideout motor(s) location may vary. Generally, they may be accessed from under the slideout in the compartment area.



CARE AND MAINTENANCE

Recreational vehicles are complex machines and require maintenance to maintain both the appearance and functionality of the coach. General maintenance, inspection of components and seals, fluid changes, and many other maintenance items will help retain your coach's dependability, safety, visual appearance, and resale value.

IMPORTANT

Read and follow all maintenance schedules to meet warranty requirements. Preventive maintenance and scheduled maintenance items are not warrantable. Damage caused by improper or unapplied maintenance is not covered by your Newmar Limited Warranty.

How To Wash and Dry A Coach

IMPORTANT

Damage caused by improper or unapplied maintenance is not covered by your Newmar Limited Warranty.

Washing The RV

The clear coat used on all painted portions of the exterior is similar to the technology that used by car manufacturers. The same care needs to be performed and maintained on your coach exterior surface as on your automobile. Following these procedures can provide a long-lasting, high-gloss finish on your coach.

1. Make sure the coach's surface temperature is under 90° F. Never wash the vehicle in direct sunlight, while the vehicle is hot, or with hot water.
2. Rinse the entire coach to remove all loose dirt and grime. Never hold a pressure washer close to the surface. Use a fan-type spray nozzle, making sure that the water is not a single straight stream. Keep the stream at least 18 inches from the edge of any decals, as high pressure water may cause the decals to loosen and peel.
3. Most car stores offer mild car wash shampoos that are safe for clear coat finishes. You may also use baby shampoo to prevent leaving a film on the coach. Adding ½ of a cup of food grade vinegar to three gallons of water will boost the cleaning ability and will also soften the water to help minimize water spots. Rinse thoroughly to prevent soap residue accumulation.

IMPORTANT

Do not use dish soap, detergents with degreasing agents, or industrial cleaners, as they can cause damage to the finish on your coach.

IMPORTANT

Do not use solvents such as acetone, MEK, toluene, etc. on the decals. Any solvent including alcohol may soften or smear colors. Do not use lacquer thinner or paint on decals. Do not overcoat the decals with clear paint. Do not allow gasoline or other fuels to drip or stay on the decals for any length of time. If this occurs, immediately flush the area with water.

4. Use 100% cotton or Lambswool pads or wash mitts for washing the painted surfaces of your coach. Use a different mitt for washing the wheels and undercarriage.

The following products may assist you when cleaning your coach, and may be purchased through the Newmar parts department:

- Lambswool Pad (Newmar part #018461)
 - Backer Pad (Newmar part #018461A)
 - Lambswool Mitt (Newmar part #018464)
 - Extension Pole (Newmar part #018463)
5. Change the water in your wash bucket often, or place a "dirt guard" in bottom of the bucket to keep the cleaning pad or wash mitt free of dirt and debris.

⚠ IMPORTANT

Absolutely no brushes should be used on the painted surface of your coach, as it will cause damage to the finish, just as it would an automobile finish. Newmar does not support the use of any style, type, or brush material, even though it may be marketed as 'RV Safe' or 'Approved.'

⚠ CAUTION

The use of any cleaning products outside of Newmar's recommendation is at the customer's discretion. However, Newmar and BASF take no responsibility for any scratches, swirls, or damage to the finish of the coach caused by the use of non-recommended products.

Drying The RV

Drying your RV is just as important as washing it. Tap water and well water contain many chemicals that could water stain your coach's finish. After washing, dry your coach with the EZE Squeegee (Newmar part #018462) or a clean 100% leather chamois.

⚠ IMPORTANT

You can also use fresh microfiber towels for drying. Please use caution, as these towels are made partially with polyester (plastic), which can break down over time from extended use and washing, eventually causing damage to the clear coat finish.

Waxing and Polishing a Coach

This article explains the benefits and recommendations for using waxes and polishes to maintain your coach's finish.

The coating on your coach is a state-of-the-art base coat and Urethane clear coat. The clear coating is designed to protect the colored base coat, so it needs to be maintained, especially in harsh environments. Clear coats will appear to fade or lose gloss as the surface becomes contaminated by the environment. A finish that is dull or low in gloss is a result of contamination. Occasional washing alone will not adequately remove some forms of contamination and will require polishing of the finish.

The exterior finish of your coach will require a routine waxing. When water will not bead and roll off a freshly washed vehicle, a new coat of wax is needed. Wax not only improves the appearance of the vehicle, but it also protects the finish against oxidation and corrosive materials. The recommended type of wax is one that is compatible with painted or gel-coated fiberglass finishes, and contains a UV (ultra-violet) inhibitor. Buffing with a polishing compound will improve a dull or discolored finish.

⚠ IMPORTANT

When using a polishing compound that does not contain a wax preservative, reapplying a coat of hard wax after polishing is recommended.

⚠ IMPORTANT

Do not use products that contain harsh abrasives such as rubbing compounds, as these products should only be used by an experienced technician with proper training and equipment.

Benefits of Waxing and Polishing

- Remove minor surface imperfections caused by water spots and acid rain
- Remove minor scratches by filling them and leveling the surface
- Seal the pores of the finish, creating an easier-to-clean surface
- Beautify the paint finish appearance with more depth and high gloss
- Protect the paint finish from the elements

Most polishes and waxes are designed to clean and polish in one application, whether by hand or machine. A machine-applied polish will last longer than one applied by hand, as the high RPMs of the buffing wheel create heat, resulting in a deeper film with higher gloss. However, a hand-applied polish or wax will offer outstanding performance and protect the coach's finish.

Due to the variations of polishes and waxes, incorporate the following:

- Apply polish or wax while the coach is parked in a shaded area so the coach's surface is at the specified temperature according to the polish manufacturer's recommendations.
- Condition the polishing pad by rubbing a slight amount of polish on it.
- Use only the amount of polish specified in the label directions.
- Work a small area at a time.
- Rinse off and remove dried polish from crevices, trim, and moldings.

⚠ IMPORTANT

Refrain from waxing or polishing for at least 90 days from the coach's date of manufacture.

How to Winterize a Coach

This provides the Newmar-recommended step-by-step instructions for winterizing a coach.

Follow the winterizing instructions to reduce the risk of leaks caused by cracks from freezing pipes. Damage caused from the fresh water system freezing can be extensive and costly to repair. A new coach may be equipped with a similar label if the system has been winterized.

⚠ IMPORTANT

Once water has been introduced into the system, it is no longer protected and must be winterized again any time the coach may be subjected to freezing temperatures.

⚠ NOTICE

The following instructions are generic to Newmar coaches, and are NOT specific to your coach. They should only be used as a reference guide for this process. Appliances, drain locations, and plumbing components may vary by coach. The following images are for example purposes only. Your coach may or may not be equipped with the same components as shown.

This fresh water system has been protected with non-toxic anti-freeze. Please flush and drain lines before using.

AD-70



Gas Coach Water Compartment (Example Only)



Diesel Coach Water Compartment (Example Only)



Luxury Coach Water Compartment (Example Only)

When to Winterize a Coach

Although great care has been taken to build a well-insulated unit, recreational vehicles are not intended for extended use in sub-freezing weather without special precautions. When the outside temperature drops below freezing, the furnace must be turned on to keep the coach warm. Continued use in cold weather will require the coach to be winterized.

It is critical to winterize the plumbing in your coach when storing it in temperatures below freezing or using it in extremely cold conditions. If subjected to these conditions without being properly winterized, the heating system may be unable to keep the coach and its compartments above freezing temperatures.

⚠ WARNING

Winterizing is the responsibility of the consumer. Make sure you have protected the complete water system any time your coach is in freezing temperatures. Failure to complete the winterization process may result in extensive damage to the water system, appliances, and coach.

⚠ IMPORTANT

A regulated compressed air supply is needed to properly complete this procedure. The pressure should be regulated between 40 and 60 PSI (pounds per square inch). Higher pressures may cause damage.

How to Winterize a Coach

1. Drain the black and grey tanks. If equipped, also empty the macerator hose.
2. Drain the Fresh Water Tank. Open the tank drain valve located in the driver side water bay.
3. Turn off the switch(es) to the water heater or the hydronic heating system, including the burner and the 120 Volt element, depending on your coach's equipment.
4. Turn on the refrigerator.
5. While the tank is draining, remove all of the water filters. Install a bypass or the filter canister, including the whole house, refrigerator, and drink water filters (whether standard or UV), if your coach is equipped.

6. For units with a tank-style water heater instead of a hydronic heater, close the valves to the water heater, and open the bypass valve, which is normally located at the back side of the water heater. Depending on your particular floor plan, access to the back of the water heater may be located in a cabinet, the closet, or in an exterior compartment.

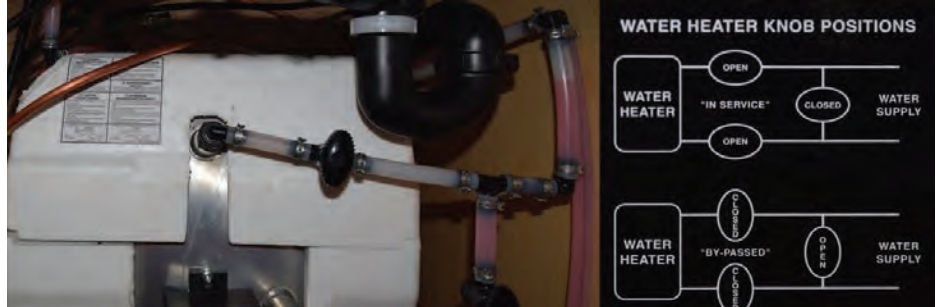

7. Remove the drain plug at the bottom of the water heater tank on the exterior of the coach.
8. Open the low point drains by turning the valve to the "open" position or by pulling up on the handle if the coach is equipped with T-Handle valves. There should be one drain for hot and one for cold, and they are normally located in the water compartment.
9. Connect the regulated air supply to the inlet of the hose from the hose reel (if equipped) or the city water fill inlet. Air will flow out of the low point drains.

⚠ NOTICE

For units with a tankless water heater, do NOT put the water heater in by-pass mode. Instead, blow it out, and install the antifreeze as directed for a hydronic heater.

⚠ IMPORTANT

The 120 Volt water heater element must be turned off by flipping the switch near the water heater's drain plug.

10. Cycle all faucets and the auto fill or tank fill valve (whichever the coach is equipped with) to all possible positions for a minimum of 10 seconds at each position. Do not forget the hot water spigot with low point drain next to the generator (if equipped).
11. Cycle the tank fill valve to all positions in order to purge water out of the lines and valve assembly.
12. After blowing the water out of the system with pressurized air, disconnect the hose, and pour approximately one cup of antifreeze into the hose. Hook the hose back up to the pressurized air, and blow the antifreeze through the hose and hose reel to protect it.
13. Close the low point drains. This must be done prior to pumping antifreeze through the lines, or the antifreeze will be pumped onto the ground.
14. Remove the whole house filter canister, and dump any remaining water, and reinstall.
15. Locate the winterizing valves marked "A" & "B" located in the water compartment.
16. Close valve "A" by rotating the valve clockwise. Open valve "B" by rotating the valve counter clockwise.
17. Remove the plug at the end of the clear winterizing hose.
18. Insert the hose into a jug or bucket of antifreeze.
19. Replace the empty jugs, or refill the bucket as needed to complete the entire process.

⚠ IMPORTANT

On coaches equipped with Aqua View Showermi\$er Fresh Water Reclamation System, cycle the valve to the bypass position to purge the water out of the line back to the fresh water tank while pressurized air supply is connected. Then place the valve back to normal flow mode to the shower head, and then purge the shower. Do not leave the valve in bypass mode when running antifreeze in the line because it will allow antifreeze into the fresh tank.

20. Turn on the water pump by activating water pump switch. Red antifreeze will start flowing through the clear hose into the water lines.

21. Run cold water from the kitchen faucet until the red potable antifreeze is detected. Run hot water from the kitchen faucet until the antifreeze is detected.
22. Proceed to the next faucet, and repeat process for each faucet, including the lavatory, shower sprayers, and outside shower faucet. If equipped, repeat the process for the instant hot water, drinking water dispensers, and hot water spigot with low point drain (next to the generator).
23. Flush each toilet until the red antifreeze is detected. If the toilet is equipped with a sprayer, activate and flush it until the antifreeze flows from the sprayer.
24. Run the dishwasher through a cycle to winterize the water inlet plumbing, as well as the pump and drain line.
25. If the coach is equipped, turn on the washing machine. Select a wash cycle setting that uses warm water to activate both the hot and cold inlet valves. Allow the washing machine to fill for approximately two minutes. Press the “cancel” and “drain” selection to begin draining the machine. This will winterize the pump and drain, as well as the washing machine’s P-trap.
26. Depress the refrigerator’s external water dispenser while holding a container to catch the fluid. Continue to let the fluid flow until the red antifreeze is detected.
27. Make sure the ice maker is turned on. Once it reaches the proper temperature, it will attempt to make ice cubes, which will become pink in color. This may take several hours. Once they become pink, turn off the ice maker and the refrigerator. Empty the ice cube tray, and clean out the ice maker and freezer area.
28. Turn off the water pump. Close the winterizing valve “B”, and open valve “A”.
29. Insert the plug into the clear hose, and stow the winterizing hose.
30. If the coach is equipped, winterize the macerator by turning it on and emptying the black and gray holding tanks, allowing the macerator and macerator hose to fill with antifreeze. If there is no macerator in the coach, use the sewer hose to drain the black tank, followed by the gray tank.

⚠ IMPORTANT

Make sure you run enough antifreeze through each faucet to fill each P-trap.

⚠ IMPORTANT

For coaches equipped with a sink or shower connected to a Saniflo Sanivite lift pump, the lift pump must be completely emptied, or enough RV antifreeze must be poured down the drains to allow the lift pump to cycle until the antifreeze concentration is sufficient for freeze protection. Pour at least one liter of antifreeze down the drain connected to the lift pump. Make sure the pump cycles at least once, then pour another liter down the drain. Wait for the lift pump to cycle again; then the remaining liquid in the lift pump should have an adequate antifreeze concentration at this point.

⚠ NOTICE

The red antifreeze may not appear instantly, as most refrigerators have a reserve for cold water. However, if you did not remove the water filter in the refrigerator in Step 5, the fluid will run clear for a long time.

How to De-Winterize a Coach

This article provides the Newmar-recommended step-by-step instructions for de-winterizing a coach.

1. Connect your water hose to a fresh potable water supply.
2. Set the auto fill or tank fill valve for city water supply.
3. Run water through each faucet, toilet, and shower on both hot and cold settings.
4. Run the dishwasher and the washing machine through a complete cycle before using.
5. Depress the refrigerator water dispenser while holding a container to catch the fluid being dispensed. Continue until clear water is dispensed.
6. Install the refrigerator filter (if equipped).
7. Turn off the water supply drain pressure from the system using low point drains. Install all filters in the system.
8. Close the low point drains.
9. Turn on the ice maker, allowing it to run through multiple cycles. Throw away any ice with antifreeze. Clean out the ice maker and the tray until clear ice is available.
10. If the coach is equipped with a water heater, install a drain plug. Open the water heater valves, and close the by-pass valve on the back side of the water heater.

⚠ NOTICE

Newmar recommends installing clean filters unless the sanitation process will also be completed at this time.

11. Turn on the fresh potable water supply.
12. Open the hot water faucet until the water heater is filled and flows through the faucet without air.
13. Flip the water heater switch to the “ON” position. This is located near the drain plug (if equipped with a water heater).
14. Check the tank level, and dump if necessary.
15. The coach is now ready to use.

How To Sanitize The Water System

This article provides the Newmar-recommended step-by-step instructions for sanitizing a complete water system.

Follow the sanitizing instructions to reduce the risk of fresh tank contamination. All of the water should be drained from the fresh water system when the coach is not in use for more than one week. Whenever possible, drain the fresh water tank before traveling or only carry what you will need to get to your destination. Water in the tank will reduce the carrying capacity of the coach.

⚠ NOTICE

The following instructions are generic to Newmar coaches, and are NOT specific to your coach. They should only be used as a reference guide for this process. Appliances, drain locations, and plumbing components may vary by coach.

OFF

ON

FRESH WATER TANK FILL

WARNING

POTABLE WATER ONLY.
SANITIZE, FLUSH AND DRAIN
BEFORE USING.
(SEE INSTRUCTION MANUAL)

FRESH WATER

Max. Pres. 60 lbs.

CITY WATER CONNECTION

CAUTION

SEWER FLUSHER

SEWER VALVE MUST
BE OPEN WHEN
USING THIS INLET

When To Sanitize The Water System

Newmar recommends sanitizing your water system under the following scenarios to discourage organic growth and contamination:

- Purchasing a new or used coach
- After your coach has been in storage for a lengthy amount of time
- At least once per year for proper maintenance
- If an unpleasant odor arises from your water

⚠ NOTICE

The Fresh Water System may need to be sanitized more often depending on the source of the water supplied to the coach.

How To Sanitize The System

1. Drain the fresh water tank by turning the tank drain valve to the open position.
2. Drain the water heater (if equipped) by removing the drain plug.

While the tank is draining, remove all of the water filters, including the refrigerator and drinking water filters (standard or UV), if your coach is equipped, and install a bypass.

3. Remove the main (whole house) filter housing.
4. Remove the filter, and pour household bleach (1/4 cup per 15 gallons, as determined by your tank capacity) into the filter housing. For example: 1.75 cups of bleach for coaches equipped with a 105 gallon fresh water tank or 1.25 cups of bleach for coaches equipped with a 75 gallon fresh water tank. This will approximately be a 50 ppm (parts per million) bleach solution.

⚠ NOTICE

Do not attempt to drain the water heater when the water is hot or the system is pressurized, as scalding may occur.

⚠ NOTICE

Not all filters have a ‘bypass,’ so it may be necessary to install the canister without the filter.

⚠ NOTICE

For any coaches not equipped with a whole house filter, skip these steps. Instead, use a funnel to pour bleach into the hose prior to hooking the coach up to a potable water supply.

5. Reinstall the housing and the water heater drain plug after it has drained completely.
6. Hook up the water hose from the hose reel (if equipped), or hook up a drinking water-safe portable hose to a potable water source.
7. Turn the valve to 'tank fill' or 'manual tank fill.'
8. Turn on the potable water source, and completely fill the water tank. (This will flush the bleach/water solution from the filter housing [Step 4] into the water tanks.)
9. Turn off the tank fill valve (on non-auto fill coaches).
10. Turn on the water pump.
11. Run water out of one faucet on both hot and cold settings until a strong bleach smell becomes evident.
12. Repeat this for all faucets, as well as the refrigerator, dishwasher, washing machine, toilets, low point drains, etc.
13. Turn on the refrigerator and the ice maker. Depending on your refrigerator model, the ice maker may have a flip lever or an ON/OFF switch. Let the ice maker run until the bleach/water solution is detected. This may take a few cycles. One cycle consists of the ice maker filling the trays with water, freezing the water, and then dumping the ice into the ice bin. This cycling process will occur automatically if the refrigerator, the ice maker, and the water pump are all turned on.
14. Disconnect the water hose, and dump out some water.
15. Pour one ounce (1 oz.) of bleach into the water hose, and reconnect it to the potable water supply.
16. Turn on the water for a brief moment to flush the bleach through the water hose, allowing it to mix in the hose reel or the portable hose used for potable water.
17. Turn off the water supply, and disconnect the water hose.
18. Cap the end of the hose.
19. Let the bleach water sit in the system for a minimum of four hours. However, for best results, allow the solution to sit overnight or up to 12 hours.
20. Drain the fresh tank using the drain valve.
21. Fill the fresh tank with clean potable water.
22. Run water out of each faucet on both hot and cold settings until the bleach smell is no longer evident.

Once the system is flushed, Newmar recommends replacing the water filters. Do not re-use the contaminated filters, as this will greatly reduce the effectiveness of the sanitization process.

⚠ NOTICE
Top off the water tank so that the sides and top of the tank are sanitized as well.

⚠ NOTICE
If the bleach smell is still noticeable, repeat steps 21-22 to flush the system again.

⚠ IMPORTANT
If algae or slime is detected in the fresh water system, it may be necessary to repeat the entire process until the system is flushed clean.

⚠ NOTICE
Sanitizing through the winterization process will not sanitize the fresh tank or all of the water lines.

Ultrafabrics Cleaning Guidelines For Flexsteel and Villa Furniture

One of the best ways to keep Ultrafabrics looking great is through proper maintenance and regular cleaning to prevent excessive dirt from accumulating.

To keep these fabrics looking their best, following these guidelines will help to extend the life of the fabric:

- Use mild soap and water for everyday cleaning
- Tough stains can be cleaned with alcohol-based or 1:5 bleach/water solutions — spray application recommended
- Do not saturate
- Rinse with clean water and wipe dry

This information is not a guarantee. Please use all cleaning and disinfecting agents safely and as instructed. The use of other cleaning agents, disinfectants, conditioners or protectants is not recommended and can degrade fabric's performance and may void Ultrafabrics warranty.

¹ Material sourced from Recommended Cleaning Instructions for Ultrafabrics

How to Clean Exterior Chrome

1. Wash chrome items with soap and water the same way you wash the exterior paint.
2. If the chrome still has some tarnish and water spots on it, clean with a soft cloth and vinegar. Add a little baking soda to the rag if you need a stronger cleaner.
3. To clean rust off of the chrome, use a piece of crinkled aluminum foil dipped in vinegar. Scrub it with light to medium pressure, while making sure the the foil stays wet with vinegar. In instances of rust and/or corrosion, you may use a very fine steel wool, but should be a last effort. Test it in an inconspicuous area to ensure no damage is occurring while using the steel wool.
4. Rinse the area with clean water after using any cleaning products.
5. Once the chrome is nice, bright, and shiny, dry it completely with a soft cloth.
6. Apply a coat of wax and buff it. Apply a second coat of wax, and buff it again.

⚠ IMPORTANT

The more often the chrome is cleaned, the easier the cleaning process. Coaches exposed to salt spray from the road or ocean air should be cleaned and waxed more often to maintain the best appearance.

How to Weigh a Coach

Below are some samples of the weight information labels that may appear in your coach.

MANUFACTURED BY / FABRIQUE PAR:		DATE:	
GVWR/PNEU	KG (LB)	TIRES/PNEU	RIMS/JANTE
FRONT/AVANT	KG (LB)		COLD INFL. PRESS./PRESS. DE GONFL. A FROID
INTERM/INTERM	KG (LB)		KPA SINGLE DUAL PSI(LPC) <input type="checkbox"/> <input type="checkbox"/>
REAR/ARRIERE	KG (LB)		KPA SINGLE DUAL PSI(LPC) <input type="checkbox"/> <input type="checkbox"/>
<small>THIS VEHICLE CONFORMS TO ALL APPLICABLE U.S. FEDERAL MOTOR VEHICLE SAFETY STANDARDS IN EFFECT ON THE DATE OF MANUFACTURE SHOWN ABOVE. THIS VEHICLE CONFORMS TO ALL APPLICABLE STANDARDS PRESCRIBED UNDER THE CANADIAN MOTOR VEHICLE SAFETY REGULATIONS IN EFFECT ON THE DATE OF MANUFACTURE. - CE VEHICULE EST CONFORME A TOUTES LES NORMES QUI LUI SONT APPLICABLES EN VERTU DU REGLEMENT SUR LA SECURITE DES VEHICULES AUTOMOBILES DU CANADA EN VIGUEUR A LA DATE DE SA FABRICATION. V.I.N./I.V.: TYPE/TYPE:</small>			

MOTOR HOME OCCUPANT AND CARGO CARRYING CAPACITY
 VIN: #####
THE COMBINED WEIGHT OF OCCUPANTS AND CARGO SHOULD NEVER EXCEED:
 XXX kg or XXX lbs
 Safety belt equipped seating capacity: XXX
CAUTION:
 A full load of water equals XXX kg or XXX lbs of cargo @ 1 kg/L (8.3 lb/gal) and the tongue weight of a towed trailer counts as cargo

Figure 1 - Motor Home Occupant and Cargo Carrying Capacity Label

⚠ IMPORTANT

The sales literature may give approximates or standards. Each individual unit may weigh differently based on the factory and/or dealer options added.

Weight Descriptions

The following definitions are provided to help with communication issues with weight and your coach.

Gross Axle Weight Rating (GAWR): The maximum permissible weight for an axle.

Gross Combination Weight Rating (GCWR): The value specified by the manufacturer of the vehicle as the maximum allowable loaded weight of the motorhome and any towed trailer or towed vehicle.

Gross Vehicle Weight Rating (GVWR): The maximum permissible weight of the fully-loaded motorhome. The GVWR is equal to or greater than the sum of the UVW plus the CCC. (GVWR ≥ UVW + CCC)

Unloaded Vehicle Weight (UVW): The weight of this motorhome as built at the factory with full fuel, engine oil, and coolants. The UVW does not include cargo, fresh water, propane gas, or dealer-installed accessories.

Cargo Carrying Capacity (CCC): The weight equal to GVWR, minus each of the following: UVW, full fresh (potable) water weight (including water heater), full propane gas weight, and SCWR. (CCC = GVWR - UVW - Water Weight - Propane Weight - SCWR)

Gross Vehicle Weight (GVW): The weight of the unit with all items and supplies that are loaded into the unit at any point in time.

Sleeping Capacity Weight Rating (SCWR): The manufacturer’s designated number of sleeping positions multiplied by 154 pounds (70 kilograms).

⚠ IMPORTANT

To assure the accuracy of your weights, make sure the unit is always level during weighing.

Weighing Your Coach

The unit has been built to comply with the component suppliers' recommended limits to provide you with a realistic CCC. When loading the unit, distribute the items so that not all of the weight is added to one area of the unit.

If you have questions as to what the weight of the unit is after it has been loaded, take the unit to a drive-on scale or use individual wheel scales, and verify that the weights are within the limits of those specified for the unit. When weighing the unit, follow these instructions. Failure to follow these instructions may give an erroneous weight reading.

To find the total weight of the unit, pull the unit onto the scales so that all of the wheels are on the scale as shown. Record the weight. This is the GVW and should not exceed the GVWR supplied by Newmar for the unit.

To find the total weight of the coach, except for the front axle, move the unit so that the front wheels are off the scales as shown. Record the weight. This weight should not exceed the total rating of the axles remaining on the scales. The front axle weight is determined by subtracting this weight from the GVW that was obtained in step one. This amount should not exceed the listed front axle weight rating.

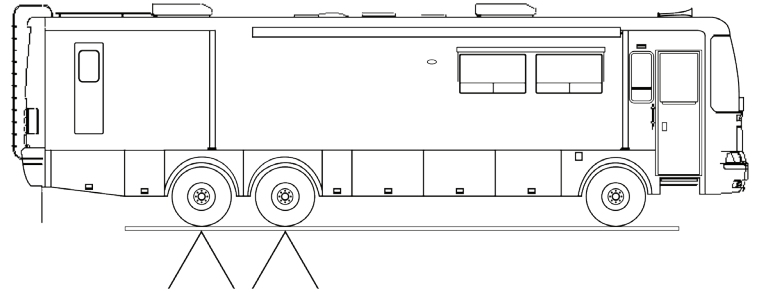
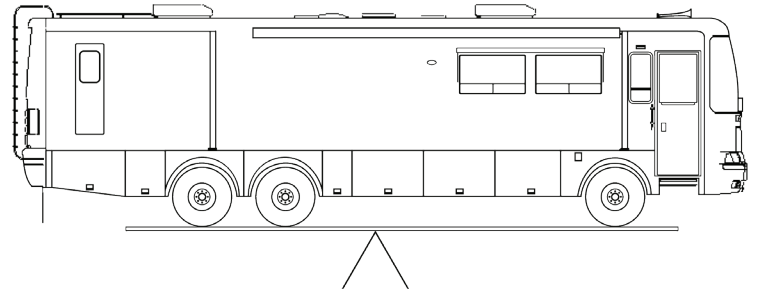

ALTERNATE WEIGHING PROCEDURE

The recommended procedure to accurately weigh a motorhome is on individual corner scales. Since these are not always available, this diagram shows how to weigh a motorhome on a typical truck scale.

Since only one corner can be weighed at a time, the remaining three corners need to be as close to the scale as possible without being on the scale, and the unit needs to be as level as possible. Remember, wind and rain can cause inaccuracies of weights.

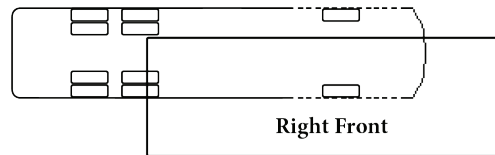
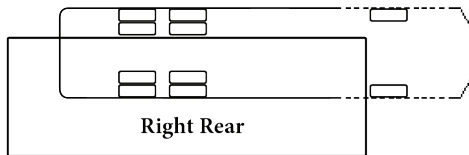
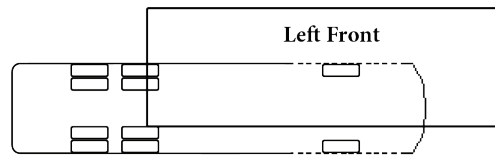
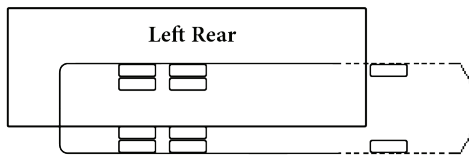

IMPORTANT

Your coach has been aligned at the factory as part of the production process. To provide optimum tire longevity and offer the best handling characteristics, Newmar recommends you have your unit re-aligned after loading your belongings. Though highly recommended, this alignment is not mandatory, and as such, is not warrantable by Newmar or the chassis manufacturer.

Routine Maintenance Schedule

All routine maintenance is the responsibility of the owner and is not covered by the Newmar Limited Warranty. Please note that damage caused by improper or unapplied maintenance is not covered by the Newmar Limited Warranty.

⚠ IMPORTANT

Always follow the chassis maintenance guidelines found in the chassis manufacturer owner's manual.

Items supplied by other manufacturers may require specific individual maintenance not listed herein. Please refer to the manufacturers' suggested maintenance guidelines in the Owner's Information Packet.

⚠ IMPORTANT

Cosmetic adjustments and alignments must be performed within the first three (3) months from date of original purchase for warranty consideration. Thereafter, these items are considered routine maintenance.

Weekly

- Test smoke alarm, carbon monoxide detector, and propane gas detector.

Monthly

- Check battery water level.

Quarterly

- Clean range hood exhaust fan filter and blades.
- Check gas lines for leaks with soap solution or leak detector.
- Check operation of windows, latches, and hinges.
- Clean the roof ducted air conditioner filter(s).
- Clean and inspect all door and window seals, and reseal where necessary.
- Inspect and reseal around the tub and shower area where necessary.
- Lubricate the exterior door hinges and latches with a graphite (silicone) lubricant.
- Check, clean, and tighten battery cables, and inspect batteries for proper fluid level.

Bi-Annually

- Inspect the slideouts for proper seals. If realignment is necessary, please contact an Authorized Newmar Service Center.
- Inspect the exterior rubber slideout seals, and apply a UV inhibitor, such as 303 Protectant.
- Rotate the tires as recommended by the tire manufacturer.
- Check all gas appliances for proper operation.
- Have the propane system inspected by a qualified technician.
- Lubricate the moveable parts on the entrance step.
- Check and replace water filters.

Annually

- Inspection of roof seams and joints should be performed by an Authorized Newmar Service Center. If resealing is necessary, it is the owner's responsibility and is not covered by the Newmar Limited Warranty.
- Check mounting bolts on all electric slideout motors for proper torque. This should be performed by an Authorized Newmar Service Center.

If any bolt is under-torqued, remove the bolt, and add blue LOCTITE® thread sealant to the bolt threads. Reinstall and torque all 5/16" bolts to 19 ft. lbs. and all 3/8" bolts to 33 ft. lbs.

- Sanitize the fresh water system.
- Wax and buff all gel-coat surfaces on the vehicle.

Service Record

Use this chart to keep track of all service work performed on the coach. For additional pages, refer to Newgle.

Date	Service Center / Dealer Name and Address	Description of Service Work Performed	Cost
xx/xx/xxxx	Example Dealer Name and Address	Example of Description of Service Work Performed	xxxx.xx



Date	Service Center / Dealer Name and Address	Description of Service Work Performed	Cost
xx/xx/xxxx	Example Dealer Name and Address	Example of Description of Service Work Performed	xxxx.xx

Fuel, Oil, and MPG Record

Use this chart to keep track of all odometer mileage, fuel, oil, and average MPG for the coach. For additional pages, refer to Newgle.

Date	Odometer Milage	Fuel (Gallons)	Oil (Quarts)	Average MPG	Cost

Date	Odometer Milage	Fuel (Gallons)	Oil (Quarts)	Average MPG	Cost

Date	Odometer Milage	Fuel (Gallons)	Oil (Quarts)	Average MPG	Cost

Date	Odometer Milage	Fuel (Gallons)	Oil (Quarts)	Average MPG	Cost

WHEN YOU KNOW
THE DIFFERENCE



NEWMAR CORPORATION | 355 N DELAWARE ST | PO BOX 30
NAPPANEE, IN 46550-0030 | 574-773-7791 | FAX 574-773-2895
www.newmarcorp.com