

# 2017 VT DP BACKSPLASH & TILE

PLEASE ACKNOWLEDGE AND DATE THE FOLLOWING ORDER/PRINT FOR APPROVAL TO BUILD, AND FAX TO NEWMAR (AT 574-773-2895) AS SOON AS POSSIBLE

DATE: \_\_\_\_\_  
SIGN: \_\_\_\_\_

**SOLID DENOTES 3/8" RECESS FOR TILE INLAY**

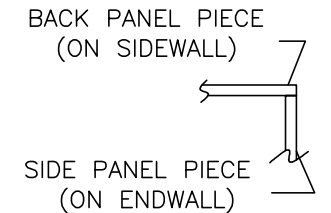
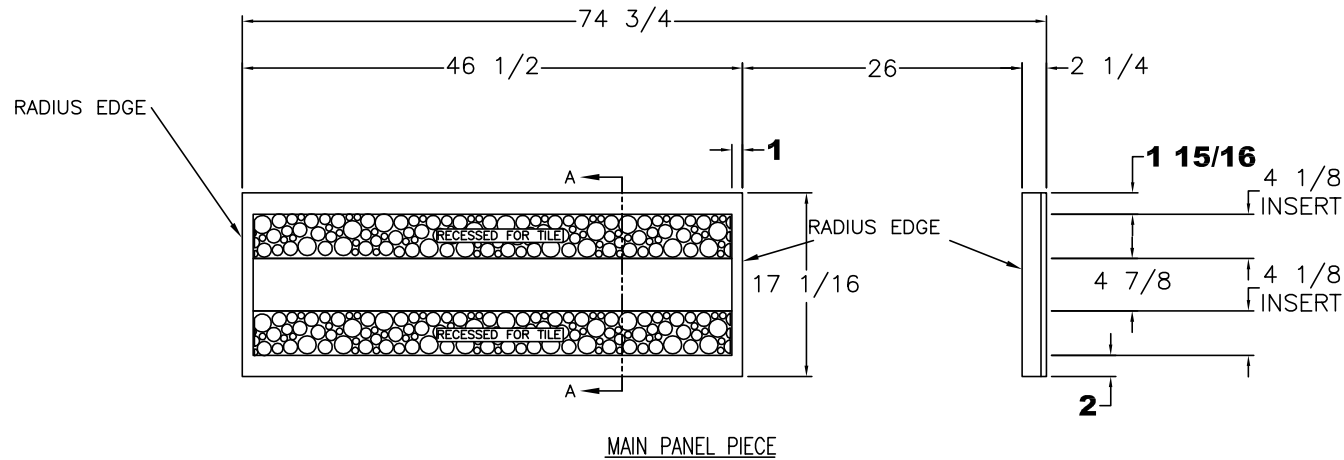

## TILE/SOLID SURFACE BACKSPLASH (T360) KITCHEN WINDOW

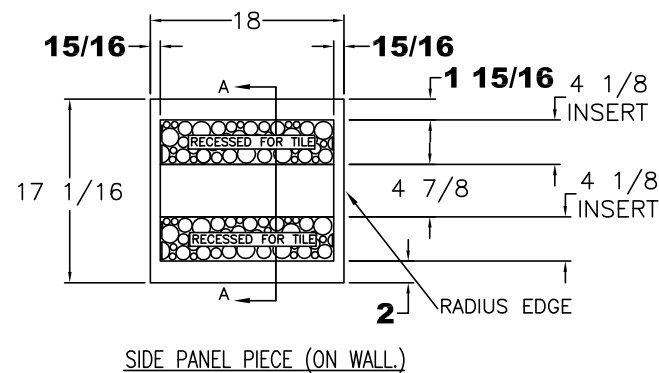

UNIT: # 606317  
DEALER: Transwest Truck, MO  
SPECIAL: # 953

<b>NEWMAR CORP</b> P.O. Box 30, Nappanee, IN. 46550	Model: (T360)	Sheet 1 OF 1	Drawn by: Z. R.	Checked by: A. M.	Revision:	By:
	Title: 77 1/2 KITCHEN CABINETS	I.D. # 2017\ SPECIALS\MOT\ 953KT	Date: 9/14/16	Date: 9/19/16	Revision:	Date:
UNITS: INCHES						By:
TITLE BLOCK: 75TB						Date:

# 2017 VT DP BACKSPLASH TILE

PLEASE ACKNOWLEDGE AND DATE THE FOLLOWING ORDER/PRINT FOR APPROVAL TO BUILD, AND FAX TO NEWMAR (AT 574-773-2895) AS SOON AS POSSIBLE  
 DATE: \_\_\_\_\_  
 SIGN: \_\_\_\_\_

**SOLID DENOTES 3/8" RECESS FOR TILE INLAY**

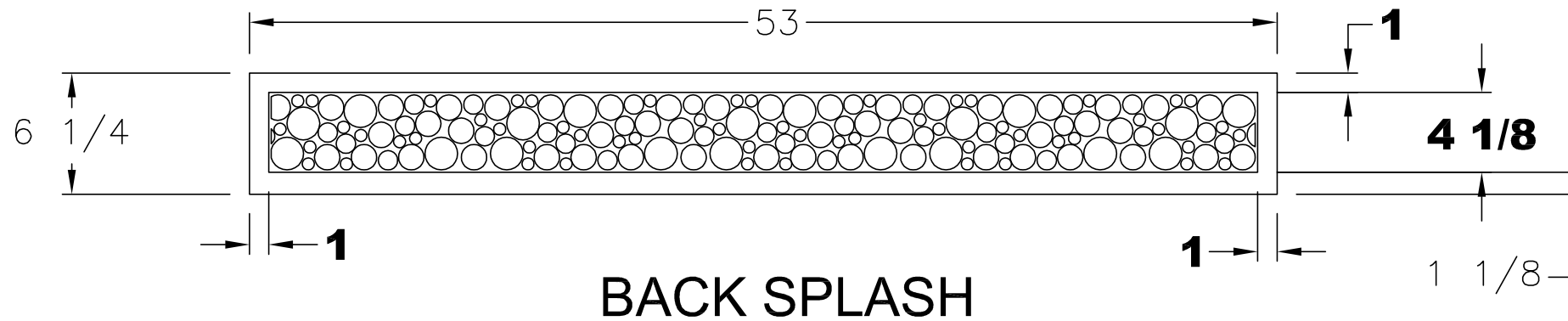

UNIT: # 606317  
 DEALER: Transwest Truck, MO  
 SPECIAL: # 953

<b>NEWMAR CORP</b> P.O. Box 30, Nappanee, IN. 46550	Model: DS DP 4369	Sheet 1 OF 1	Drawn by: Z. R.	Checked by: A. M.	Revision:	By:
	Title: 53 LAV BASE & TOP	I.D. # 2017\ SPECIALS\MOT\ 953LV	Date: 9/14/16	Date: 9/19/16	Revision:	Date:
UNITS: INCHES						By:
TITLE BLOCK: 1TB						Date:

# 2017 VT DP BACKSPLASH TILE

PLEASE ACKNOWLEDGE AND DATE THE FOLLOWING ORDER/PRINT FOR APPROVAL TO BUILD, AND FAX TO NEWMAR (AT 574-773-2895) AS SOON AS POSSIBLE

DATE: \_\_\_\_\_

SIGN: \_\_\_\_\_

**SOLID DENOTES 3/8" RECESS FOR TILE INLAY**

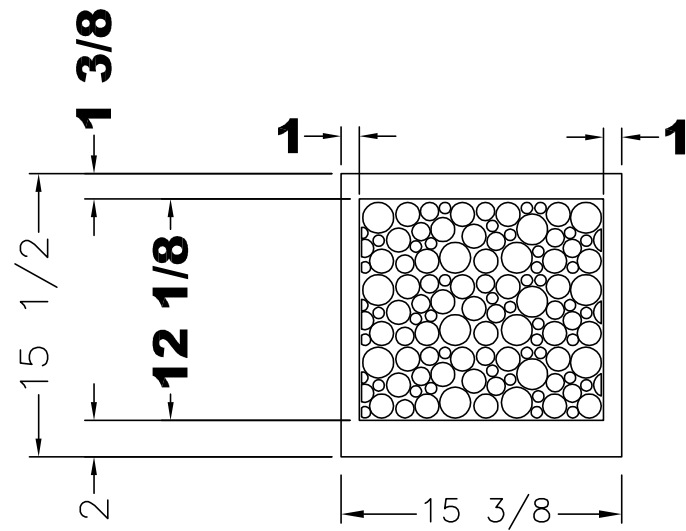

VIEW (A)

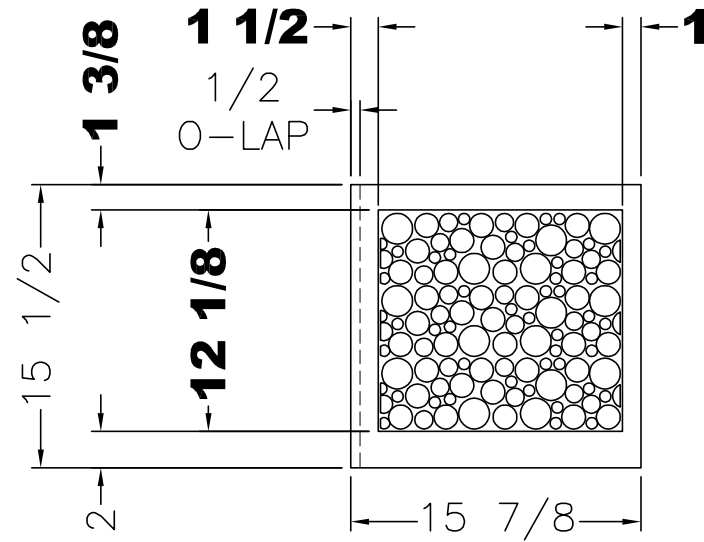

VIEW (B)

UNIT: # 606317  
DEALER: Transwest Truck, MO  
SPECIAL: # 953

## CENTER TILE LAYOUT

<b>NEWMAR CORP</b> P.O. Box 30, Nappanee, IN. 46550 UNITS: INCHES TITLE BLOCK: 1TB	Model:	Sheet	Drawn by:	Checked by:	Revision:	By:
	DS DP 4369	1 OF 1	Z. R.	A. M.		Date:
	Title:	I.D. # 2017\	Date:	Date:	Revision:	By:
	16 LAV BASE & TOP	SPECIALS\MOT\	9/14/16	9/19/16		Date:
		953LV1				

NOTE: ALL DIMENSIONS POINT TO TILE GEOMETRY EXCEPT WHERE NOTED

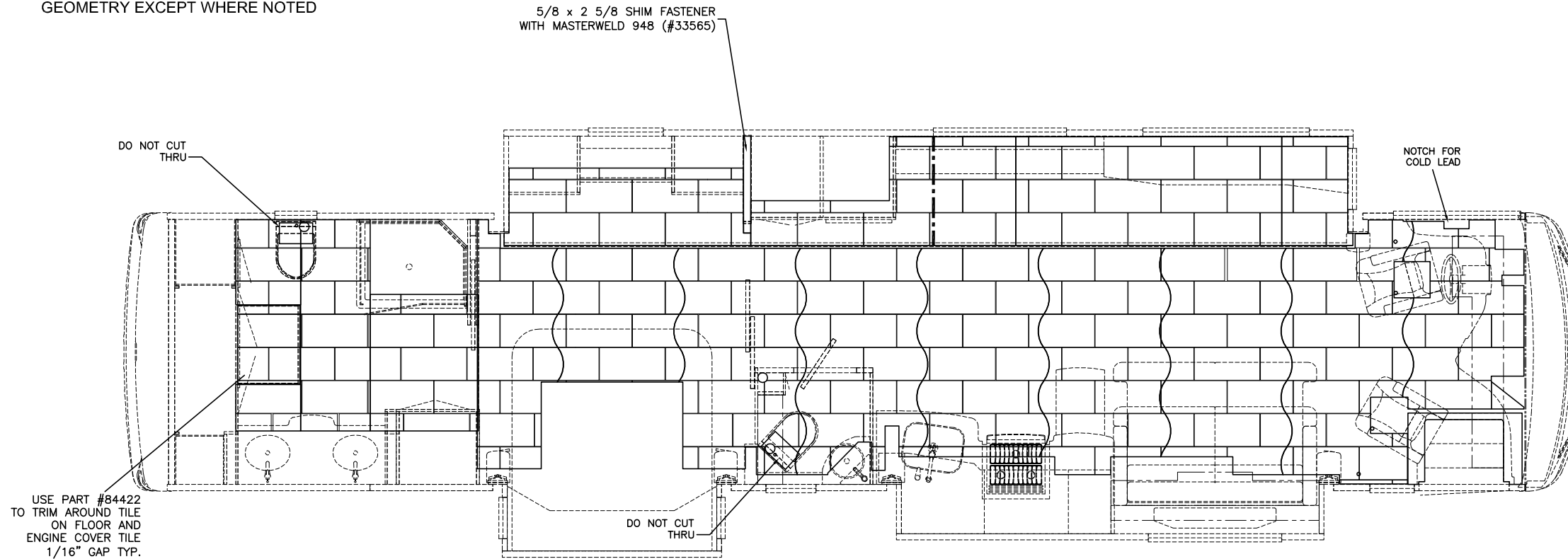

# 2017 VT DP TILE

## 11 3/4 x 23 5/8

PLEASE ACKNOWLEDGE AND DATE THE FOLLOWING ORDER/PRINT FOR APPROVAL TO BUILD, AND FAX TO NEWMAR (AT 574-773-2895) AS SOON AS POSSIBLE  
 DATE: \_\_\_\_\_  
 SIGN: \_\_\_\_\_

UNIT: # 606317  
 DEALER: Transwest Truck, MO  
 SPECIAL: # 953

<b>NEWMAR CORP</b> P.O. Box 30, Nappanee, IN. 46550 UNITS: INCHES TITLE BLOCK: 3125TB	Model: (K643)	Sheet	Drawn by:	Checked by:	Revision:	By:
	DS DP 4369	1 OF 1	Z. R.	A. M.		Date:
	Title: STANDARD TILE LAYOUT	I.D. # 2017\ SPECIALS\MOT\ 953TILE	Date: 9/14/16	Date: 9/19/16	Revision:	By:
						Date: