

1/2" SOLID SURFACE
CNC AS (1) PIECE

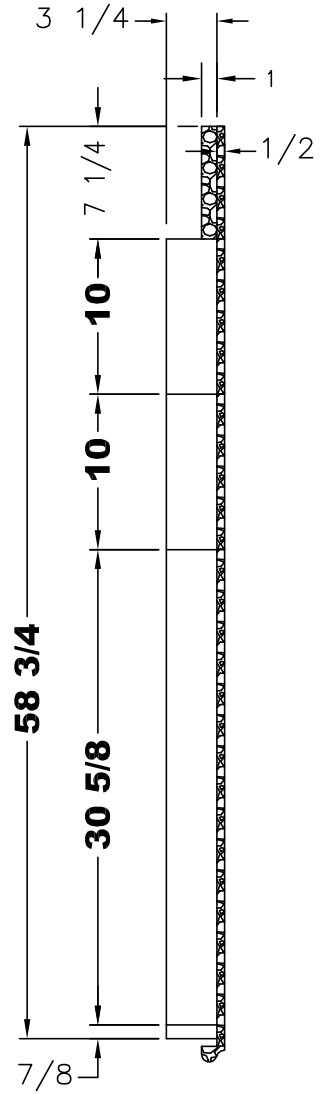

SECTION A-A

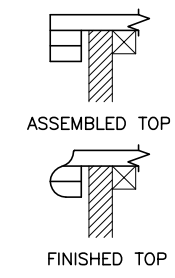
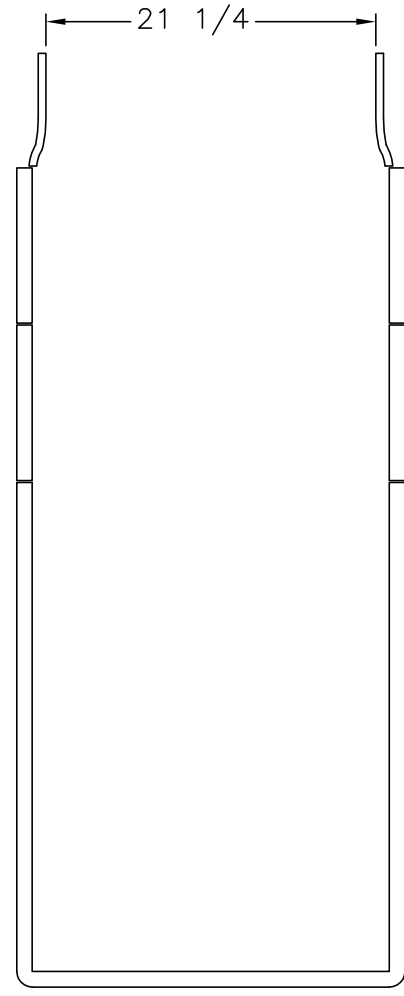

PLEASE ACKNOWLEDGE AND DATE THE FOLLOWING
 ORDER/PRINT FOR APPROVAL TO BUILD, AND FAX TO
 NEWMAR (AT 574-773-2895) AS SOON AS POSSIBLE
 DATE: _____
 SIGN: _____

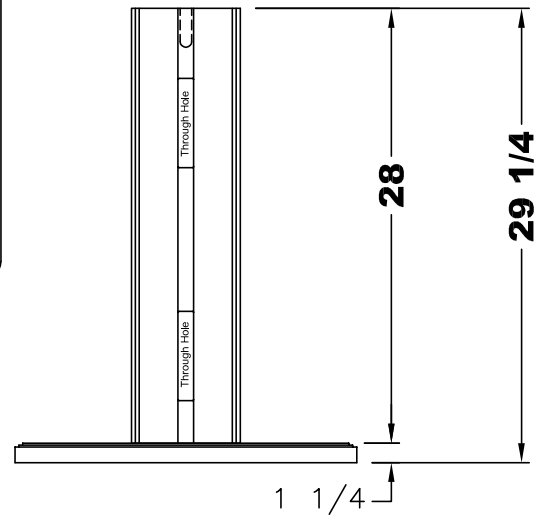

FREE STANDING LEG FOR TABLE

UNIT: # 606482
 DEALER: Tom Lindstrom RV
 SPECIAL: # 1599

NEWMAR CORP P.O. Box 30, Nappanee, IN. 46550 UNITS: INCHES TITLE BLOCK: 1TB	Model: DS DP 4018 (K645)	Sheet 1 OF 1	Drawn by: Z. R.	Checked by: A. M.	Revision:	By:
	Title: 75" DINETTE BUFFET	I.D. # 2017 \ SPECIALS \ MOT \ 1599DT	Date: 1/10/17	Date: 1/12/17	Revision:	Date:

2017 LA DP BACKSPLASH & TILE

PLEASE ACKNOWLEDGE AND DATE THE FOLLOWING ORDER/PRINT FOR APPROVAL TO BUILD, AND FAX TO NEWMAR (AT 574-773-2895) AS SOON AS POSSIBLE

DATE: _____

SIGN: _____

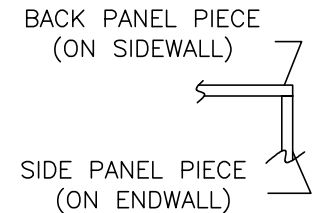
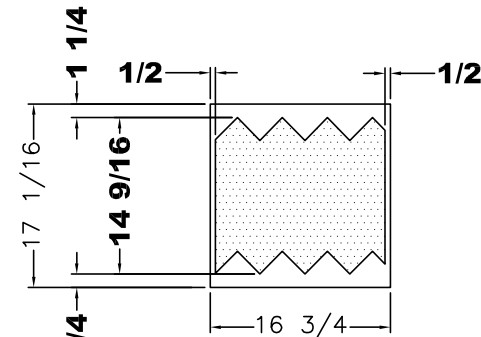
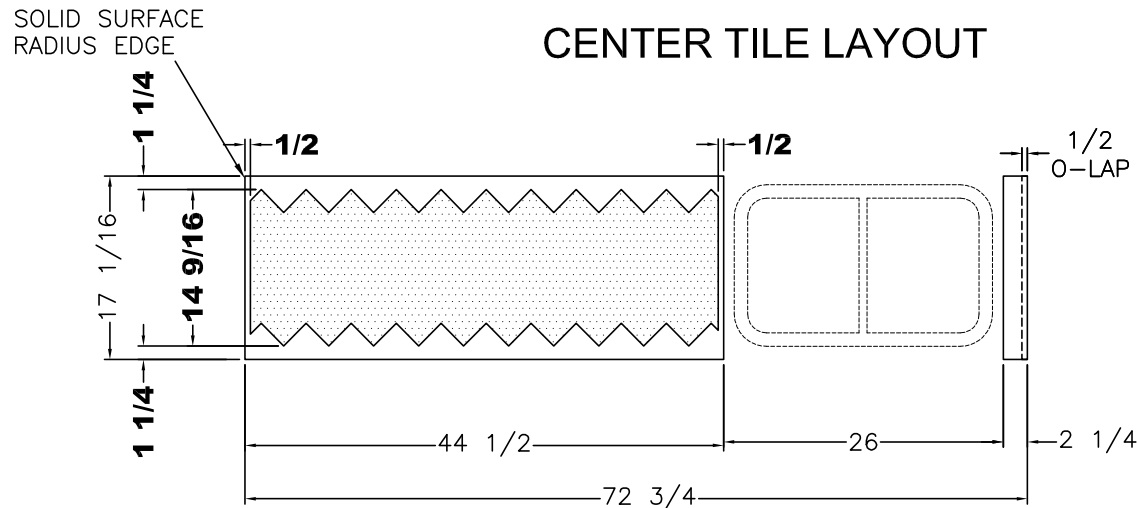

INSTALLATION DETAIL
(SCALE 4X)

SIDE PANEL PIECE (ON WALL)

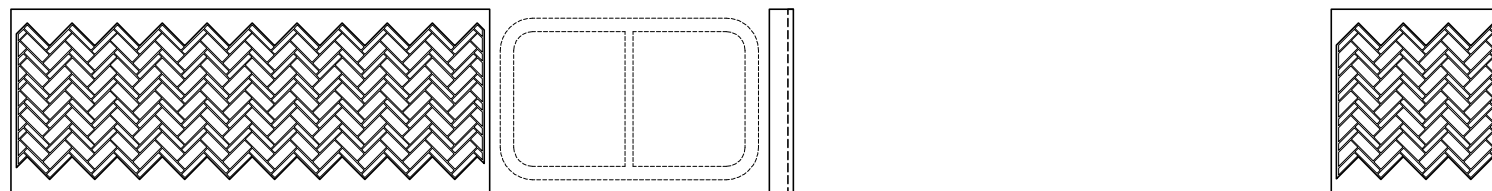

TILE/SOLID SURFACE BACKSPLASH (T360) KITCHEN WINDOW

**SOLID DENOTES 3/8"
RECESS FOR TILE INLAY**

UNIT: # 606482
DEALER: Tom Lindstrom RV
SPECIAL: # 1599

NEWMAR CORP P.O. Box 30, Nappanee, IN. 46550 UNITS: INCHES TITLE BLOCK: 75TB	Model: (T360) DS DP 4018	Sheet 1 OF 1	Drawn by: Z. R.	Checked by: A. M.	Revision:	By:
	Title: KITCHEN BACKSPLASH	I.D. # 2017\ SPECIALS\MOT\ 1599KT	Date: 2/13/17	Date: 2/13/17	Revision:	Date:

2017 LA DP BACKSPLASH TILE

PLEASE ACKNOWLEDGE AND DATE THE FOLLOWING ORDER/PRINT FOR APPROVAL TO BUILD, AND FAX TO NEWMAR (AT 574-773-2895) AS SOON AS POSSIBLE

DATE: _____
SIGN: _____

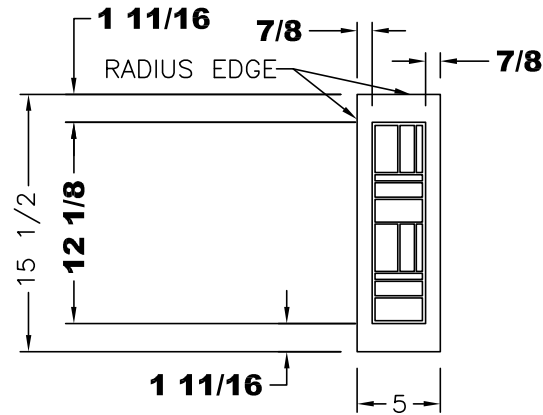

VIEW A

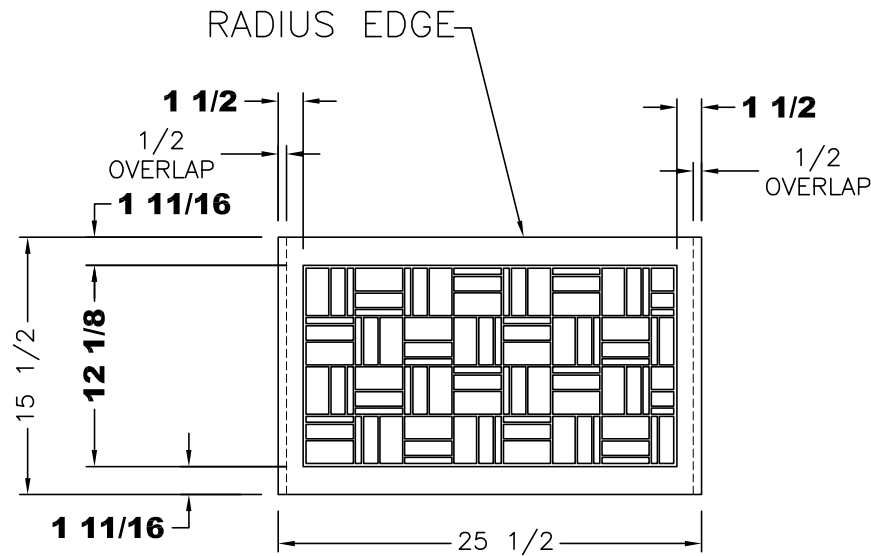

VIEW B

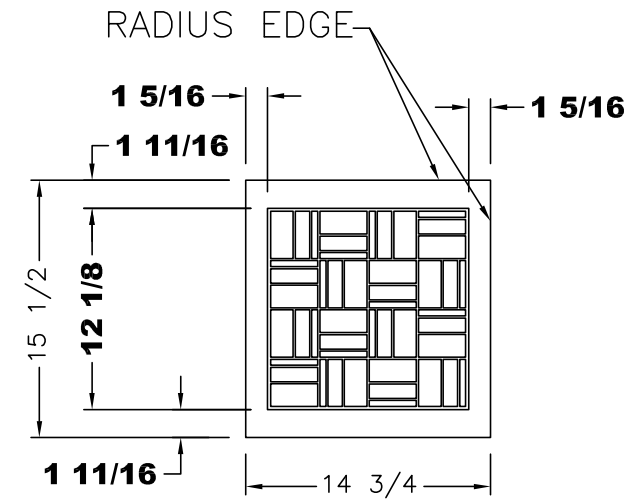

VIEW C

UNIT: # 606482
DEALER: Tom Lindstrom RV
SPECIAL: # 1599

CORIAN BACKSPLASH
SOLID DENOTES 3/8"
RECESS FOR TILE INLAY

NEWMAR CORP P.O. Box 30, Nappanee, IN. 46550 UNITS: INCHES TITLE BLOCK: 1TB	Model:	Sheet	Drawn by:	Checked by:	Revision:	By:
	DS DP 4018	1 OF 1	Z. R.	A. M.		Date:
	Title:	I.D. # 2017\	Date:	Date:	Revision:	By:
	25 1/2 LAV BASE & TOP	SPECIALS\MOT\	2/13/17	2/13/17		Date:
		1599LV				

2017 LA DP BACKSPLASH TILE

PLEASE ACKNOWLEDGE AND DATE THE FOLLOWING ORDER/PRINT FOR APPROVAL TO BUILD, AND FAX TO NEWMAR (AT 574-773-2895) AS SOON AS POSSIBLE

DATE: _____
SIGN: _____

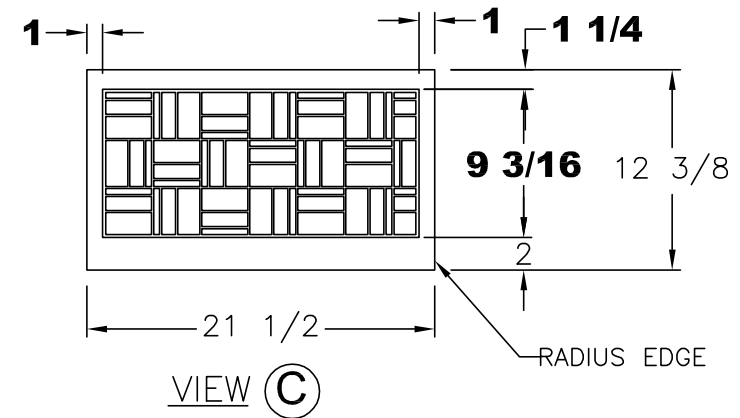
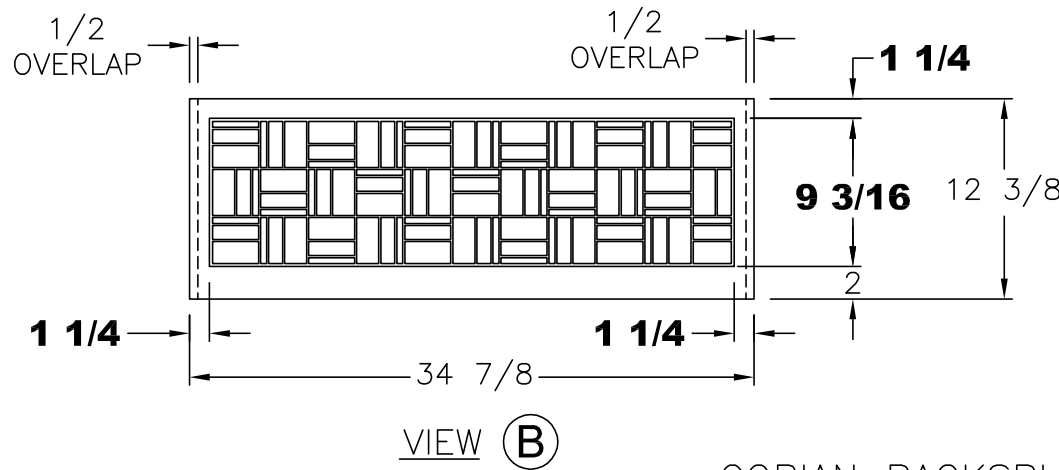
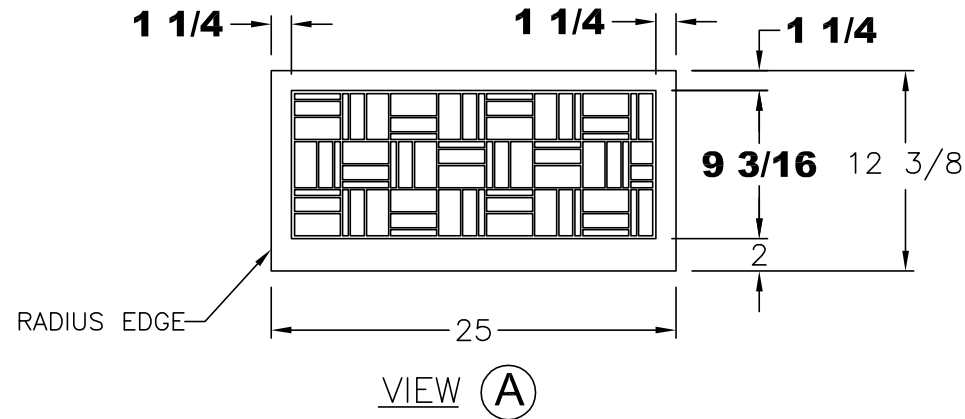

CORIAN BACKSPLASH
SOLID DENOTES 3/8"
RECESS FOR TILE INLAY

UNIT: # 606482
DEALER: Tom Lindstrom RV
SPECIAL: # 1599

NEWMAR CORP P.O. Box 30, Nappanee, IN. 46550 UNITS: INCHES TITLE BLOCK: 1TB	Model:	Sheet	Drawn by:	Checked by:	Revision:	By:
	DS DP 4018	1 OF 1	Z. R.	A. M.		Date:
	Title:	I.D. # 2017\	Date:	Date:	Revision:	By:
	35 3/4 LAV BASE & TOP	SPECIALS\MOT\ 1599LV1	2/13/17	2/13/17		Date:

NOTE: ALL DIMENSIONS POINT TO TILE GEOMETRY EXCEPT WHERE NOTED

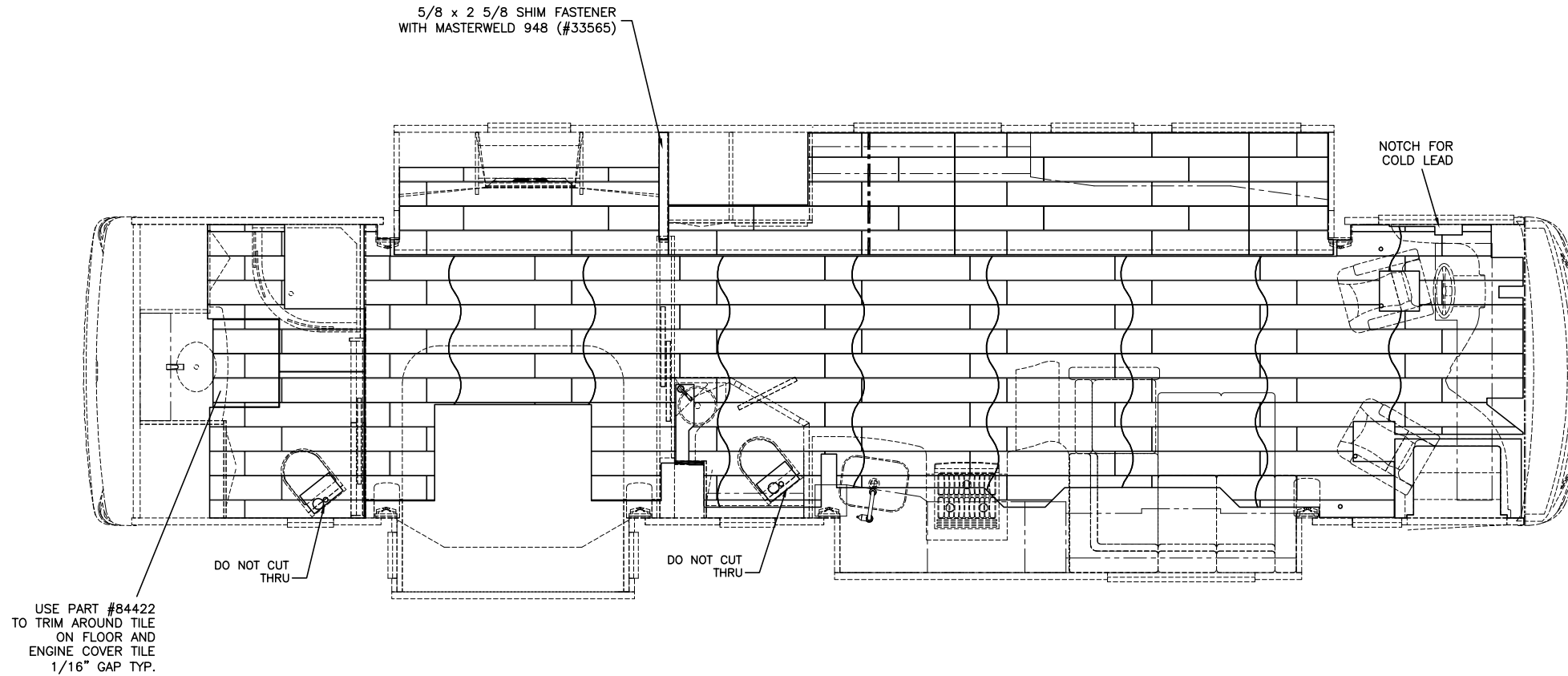

**2017 EX DP TILE
7 3/4 x 47**

PLEASE ACKNOWLEDGE AND DATE THE FOLLOWING ORDER/PRINT FOR APPROVAL TO BUILD, AND FAX TO NEWMAR (AT 574-773-2895) AS SOON AS POSSIBLE
 DATE: _____
 SIGN: _____

UNIT: # 606482
 DEALER: Tom Lindstrom RV
 SPECIAL: # 1599

NEWMAR CORP P.O. Box 30, Nappanee, IN. 46550	Model: (K170)	Sheet 1 OF 1	Drawn by: Z. R.	Checked by: A. M.	Revision:	By:
	Title: STANDARD TILE LAYOUT	I.D. # 2017\ SPECIALS\MOT\ 1599TILE	Date: 2/13/17	Date: 2/13/17	Revision:	Date:
UNITS: INCHES						By:
TITLE BLOCK: 3125TB						Date: